

# PENTAX DSI-100 SERIES FREQUENCY INVERTER

## User's Manual



# Introduction

First of all, thank you for choosing DSI-100 series inverter.

DSI-100 series inverter is a general purpose, stable and high performance current vector inverter. Whether VF control or open loop vector control operation, it has reached the industry's leading control level. At the same time, it has random PWM control technology beyond its peers. It can run normally in severe environments such as power grid fluctuation, high temperature, high humidity and concentrated dust, and has extremely high reliability.

Besides excellent performance and reliability, DSI-100 is also more powerful. Simple PLC, built-in PID, multi-stage speed, high-speed pulse, communication and other operation modes can also realize regular operation and switch operation between the two motors. In addition to the standard RS485 interface.

DSI-100 series frequency inverters can be used to drive various kinds of automatic production equipment such as fans, water pumps, textile, paper drawing, machine tools, packaging, food, etc.

## Precautions

- ◆ In order to explain the details of the product, the illustrations in this manual sometimes show the state with the cover or safety cover removed. When using this product, please be sure to install the case or cover according to the regulations, and operate according to the contents of the manual.
- ◆ The illustrations in this instruction manual are for illustration only and may differ from the product you ordered.
- ◆ Due to product upgrades or specification changes, and in order to improve the convenience and accuracy of the manual, the contents of this manual will be changed in time.
- ◆ If you need to order the instruction manual due to damage or loss, please contact the regional agents of our company, or contact our customer service center directly.
- ◆ If you still have some problems in use, please contact the customer service center of our company.

## Content

|  |    |
|--|----|
| Chapter 1: Inspection and Safety Precautions ..... | 1  |
| 1.1. Check after unpacking .....                   | 1  |
| 1.1.1. Nameplate Description .....                 | 1  |
| 1.1.2. Model description .....                     | 1  |
| 1.3. Precautions .....                             | 4  |
| 1.4. Scope of use .....                            | 6  |
| Chapter 2: Standard Specifications .....           | 7  |
| 2.1. Technical Specifications .....                | 7  |
| 2.2 Standard specification .....                   | 7  |
| 2.3 Sharp and Dimension .....                      | 10 |
| 2.3.1 Product appearance drawing .....             | 10 |
| 2.3.2 Installation hole size .....                 | 10 |
| 2.3.3 Dimensions keyboard housing .....            | 11 |
| Chapter 3: Installation and Circuits Diagram ..... | 12 |
| 3.1 Use environment .....                          | 12 |
| 3.2 Wire diagram .....                             | 12 |
| 3.3 Control circuit terminal .....                 | 13 |

|  |    |
|--|----|
| 3.3.1 Control circuit terminal layout .....            | 13 |
| 3.4. Wiring Precautions .....                          | 14 |
| Chapter 4: Operating Keyboard.....                     | 16 |
| 4.1 Operation keyboard appearance.....                 | 16 |
| 4.2 Introduction to Keyboard Indicators .....          | 16 |
| Chapter 5: Summary of function parameters .....        | 18 |
| Group 00 Monitoring Function Group .....               | 18 |
| Group 01 Basic Function Group .....                    | 19 |
| Group 02 1st Motor Parameters .....                    | 22 |
| Group 03 The 1st motor vector control parameters ..... | 24 |
| Group 04 V/F Control Parameters .....                  | 25 |
| Group 05 Input Terminals.....                          | 26 |
| Group 06 Output Terminals .....                        | 29 |
| Group 07 Start/Stop Control.....                       | 31 |
| Group 08 Keyboard and Display .....                    | 32 |
| Group 09 Auxiliary Functions .....                     | 34 |
| Group 10 Faults and Protections.....                   | 36 |
| Group 11 PID functions.....                            | 41 |
| Group 12 Swing Frequency, Fixed Length and Count ..... | 43 |
| Group 13 Multi-Reference and Simple PLC Function.....  | 43 |
| Group 14 Communication Parameters .....                | 46 |
| Group 17 Function Code Management .....                | 46 |
| Group 23 Control Optimization Parameters .....         | 47 |
| Chapter 6: Parameter Description .....                 | 49 |
| Group 00 Monitoring parameter group .....              | 49 |
| Group 01 Basic Function Group .....                    | 52 |
| Group 02 1st Motor Parameters .....                    | 59 |
| Group 03 Vector Control Parameters .....               | 62 |
| Group 04 V/F Control Parameters .....                  | 64 |
| Group 05 Input Terminals.....                          | 71 |
| Group 06 Output Terminals .....                        | 79 |

|   |     |
|---|-----|
| Group 07 Start/Stop Control .....                               | 84  |
| Group 08 Keyboard and Display .....                             | 89  |
| Group 09 Auxiliary Functions .....                              | 92  |
| Group 10 Faults and Protections.....                            | 100 |
| Group 11 PID functions.....                                     | 106 |
| Group 12: Swing Frequency, Fixed Length and Count.....          | 112 |
| Group13 Multi-stage speed command and simple PLC function ..... | 114 |
| Group14 Communication parameters .....                          | 118 |
| Group 17 User Password.....                                     | 118 |
| Group 23 Control optimization parameters .....                  | 119 |
| Chapter 7 Fault Display and settlement .....                    | 122 |
| Chapter 8 RS485 Communication Protocol .....                    | 130 |

# Chapter 1: Inspection and Safety Precautions

The inverters have been strictly tested and quality inspected before leaving the factory. After purchasing, please check whether the packaging of the product is damaged due to careless transportation; whether the specifications and models of the product are consistent with the model ordered. If you have any questions, please contact local dealers, or contact our company directly.

## 1.1. Check after unpacking

- ※ The inspection includes one machine, one instruction manual, and one warranty card.
- ※ Check the nameplate on the side of the inverter to make sure that the product in your hand is the one you ordered.

### 1-1-1. Nameplate Description

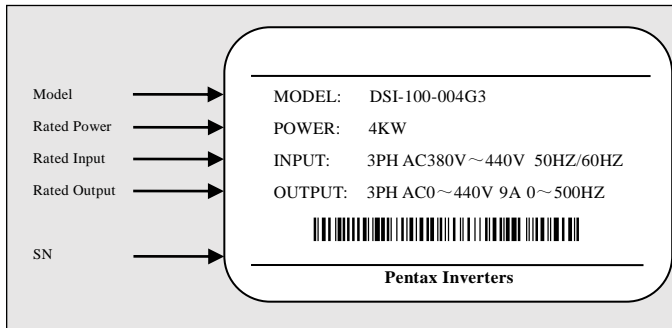
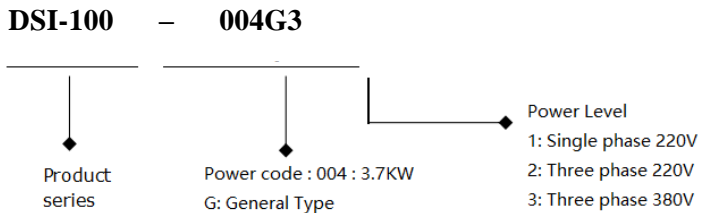

Figure 1-1 Nameplate Description

### 1-1-2. Model description



## 1-2. Safety Precautions

In this manual, safety precautions are divided into the following two categories:







**Danger:** A situation that may result in serious injury or even death due to the danger caused by not operating as required;



**CAUTION:** Moderate or minor injury, and equipment damage may result due to hazards caused by not operating as required;

| Type of Security Matter | Contents of safety precautions   |
|-------------------------|--|
| <br>Danger              | <ul style="list-style-type: none"> <li>Do not install it if you find that the control system has entered water, or parts are missing or damaged when unpacking!</li> <li>If the packing list does not match the actual name, please do not install it!</li> <li>It should be handled with care, otherwise there is a danger of damage to the equipment!</li> <li>Please do not use damaged drives or inverters with missing parts. There is a danger of injury!</li> <li>Do not touch the components of the control system with your hands, otherwise there is a danger of static electricity damage!</li> </ul>   |
| <br>Danger              | <ul style="list-style-type: none"> <li>Please install it on flame-retardant objects such as metal; keep away from combustibles. Otherwise it may cause a fire!</li> <li>Do not twist the fixing bolts of the equipment components at will, especially the bolts marked with red!</li> </ul>  |
| <br>Caution             | <ul style="list-style-type: none"> <li>Do not let the wire head or screw fall into the driver. Otherwise, the drive will be damaged!</li> <li>Please install the driver in a place with less vibration and avoid direct sunlight.</li> <li>When more than two inverters are placed in the same cabinet, please pay attention to the installation position to ensure the heat dissipation effect.</li> </ul>  |
| <br>Danger              | <ul style="list-style-type: none"> <li>The instruction of this manual must be followed, and the construction shall be carried out by professional electrical engineering personnel, otherwise there will be unexpected dangers!</li> <li>There must be a circuit breaker between the inverter and the power supply, otherwise a fire may occur!</li> <li>Before wiring, please confirm that the power supply is in a zero-energy state, otherwise there is a danger of electric shock!</li> <li>Please properly ground the inverter according to the standard, otherwise there is danger of electric shock!</li> <li>Never connect the input power to the output terminals (U, V, W) of the inverter. Pay attention to the markings of the terminals, and do not connect the wrong wires! Otherwise, the drive will be damaged!</li> <li>Ensure that the wiring conforms to the EMC requirements and the safety standards of the area where it is located. Please refer to the recommendations in the manual for the wire diameter used. Otherwise an accident may occur!</li> <li>Never connect the braking resistor directly between the DC bus + and - terminals. Otherwise it will cause a fire!</li> <li>Encoder must use shielded wire, and the shielding layer must ensure that the single end is reliably grounded!</li> </ul> |
| <br>Caution             | <ul style="list-style-type: none"> <li>Please confirm whether the voltage level of the input power is consistent with the rated voltage level of the inverter; whether the wiring positions of the power input terminals (R, S, T) and output terminals (U, V, W) are correct; and pay attention to check the connection with the drive. Whether there is a short circuit in the connected peripheral circuits, and whether the connected lines are fastened, otherwise the driver will be damaged!</li> <li>Any part of the inverter does not need to be subjected to the withstand voltage test, the product has been tested before leaving the factory. Otherwise it will cause an accident!</li> </ul>   |

| Type of Security Matter  | Contents of safety precautions   |
|--|--|
| <br>Danger  | <ul style="list-style-type: none"> <li>●The inverter can only be powered on after the cover is covered. Otherwise it may cause electric shock!</li> <li>●The wiring of all peripheral accessories must comply with the instructions of this manual, and make the correct wiring according to the circuit connection method provided in this manual. Otherwise it will cause an accident!</li> </ul>  |
| <br>Danger  | <ul style="list-style-type: none"> <li>●Do not open the cover after power on. Otherwise there is a danger of electric shock!</li> <li>●Do not touch the driver and peripheral circuits with wet hands. Otherwise there is a danger of electric shock!</li> <li>●Do not touch any input and output terminals of the inverter. Otherwise there is a danger of electric shock!</li> <li>●At the beginning of power-on, the inverter automatically performs safety detection on the external strong current circuit. At this time, do not touch the U, V, W terminals of the driver or the motor terminals, otherwise there is a danger of electric shock!</li> <li>●If parameter identification is required, please pay attention to the danger of injury during motor rotation. Otherwise it may cause an accident!</li> <li>●Do not arbitrarily change the parameters of the inverter manufacturer. Otherwise, it may cause damage to the equipment!</li> </ul> |
| <br>Danger  | <ul style="list-style-type: none"> <li>●Do not touch the cooling fan and discharge resistor to test the temperature. Otherwise burns may occur!</li> <li>●Non-professional technicians should not detect signals during operation. Otherwise it may cause personal injury or equipment damage!</li> </ul>  |
| <br>Caution | <ul style="list-style-type: none"> <li>●When the inverter is running, it should be avoided that something falls into the equipment. Otherwise, the equipment will be damaged!</li> <li>●Do not use the method of contactor on and off to control the start and stop of the drive. Otherwise, the equipment will be damaged!</li> </ul>   |
| <br>Danger  | <ul style="list-style-type: none"> <li>●Do not repair and maintain the equipment with electricity. Otherwise there is a danger of electric shock!</li> <li>●Confirm that the maintenance and repair of the drive can only be carried out when the voltage of the inverter is lower than 36V, which shall be subject to two minutes after the power is cut off. Otherwise, the residual charge on the capacitor will cause harm to people!</li> <li>●Persons without professional training are not allowed to repair and maintain the inverter. Otherwise, personal injury or equipment damage may be caused!</li> <li>●After the inverter is replaced, the parameters must be set, and all pluggable plug-ins must be plugged and unplugged in the case of power failure!</li> </ul>   |



### 1-3. Precautions

| Item | note type   | Content   |
|------|---|---|
| 1    | Motor insulation inspection   | Before using the motor for the first time, before using it for a long time, and during regular inspection, the motor insulation should be checked to prevent damage to the inverter due to the insulation failure of the motor winding. During insulation inspection, the motor connection must be separated from the inverter. It is recommended to use a 500V voltage megger, and the measured insulation resistance should be no less than 5MΩ.  |
| 2    | Thermal protection of the motor   | If the selected motor does not match the rated capacity of the inverter, especially when the rated power of the inverter is greater than the rated power of the motor, be sure to adjust the motor protection related parameter values in the inverter or install a thermal Relay in front of the motor to protect the motor.   |
| 3    | Operation above power frequency   | This inverter can provide an output frequency of 0Hz to 500.00Hz. If the customer needs to run above 50Hz, please consider the bearing capacity of the mechanical device.   |
| 4    | Vibration of mechanical devices   | At some output frequencies, the inverter may encounter the mechanical resonance point of the load device, which can be avoided by setting the jump frequency parameter in the inverter.   |
| 5    | About motor heating and noise   | Because the output voltage of the inverter is a PWM wave and contains certain harmonics, the temperature rise, noise and vibration of the motor will increase slightly compared with the power frequency operation.   |
| 6    | When there is a varistor on the output side or a capacitor to improve power factor  | The output of the inverter is PWM wave. If the output side is equipped with a capacitor for improving power factor or a varistor for lightning protection, it is easy to cause instantaneous overcurrent of the inverter or even damage the inverter. Please do not use.  |
| 7    | Switch devices such as contactors used at the input and output ends of the inverter | If a contactor is installed between the power supply and the input end of the inverter, it is not allowed to use this contactor to control the start and stop of the inverter. When the contactor must be used to control the start and stop of the inverter, the interval should not be less than one hour. Frequent charging and discharging may reduce the service life of the capacitors in the inverter. If there is a switch device such as a contactor between the output end and the motor, make sure that the inverter is switched on and off when there is no output, otherwise the modules in the inverter may be damaged. |
| 8    | Use other than rated voltage  | It is not suitable to use the DSI-100 series inverter outside the allowable working voltage range specified in the manual, which may cause damage to the components in the inverter. If necessary, use the corresponding boost or step-down device for voltage transformation.  |
| 9    | Three-phase input is changed to two-phase input                                     | The three-phase inverter in the DSI-100 series cannot be changed to two-phase. Failure to do so will result in malfunction or damage to the inverter.   |
| 10   | Lightning strike protection   | This series of inverters is equipped with lightning strike overcurrent protection device, which has a certain self-protection ability for induced lightning. For places where lightning occurs frequently, customers should also install protection on the front end of the inverter.   |
| 11   | Altitude and Derating Usage   | In areas with an altitude of more than 1000m, the cooling effect of the inverter is deteriorated due to the thin air, so it is necessary to derate the use. In this case, please contact our company for technical consultation.  |
| 12   | Some special usage  | If the customer needs to use methods other than the recommended wiring diagram provided in this manual, such as common DC bus, please consult our company.  |

| Item | note type                                      | Content   |
|------|--|---|
| 13   | Pay attention to the scrapping of the inverter | The electrolytic capacitors of the main circuit and the electrolytic capacitors on the printed board may explode when they are burned. Toxic gas will be generated when the plastic parts are burned. Please dispose of them as industrial waste.   |
| 14   | About the Adapter Motor                        | <p>1) The standard matching motor is a four-pole squirrel-cage asynchronous induction motor. If it is not the above motor, please select the inverter according to the rated current of the motor.</p> <p>2) The cooling fan of the non-variable frequency motor is coaxially connected to the rotor shaft, and the cooling effect of the fan decreases when the speed decreases. Therefore, if the motor is overheated, a strong exhaust fan should be installed or replaced with a frequency conversion motor;</p> <p>3) The frequency converter has built-in standard parameters of the adapted motor. According to the actual situation, it is necessary to identify the motor parameters or modify the default values to match the actual values as much as possible, otherwise the operation effect and protection performance will be affected;</p> <p>4) Due to the short circuit in the cable or the motor, the inverter will alarm, or even the machine will be fried. Therefore, please first perform an insulation short-circuit test on the initially installed motor and cable, and this test should also be performed frequently during routine maintenance. Note that the inverter must be completely disconnected from the tested part when doing this test.</p>   |
| 15   | other  | <p>1) Never connect the AC power supply to the U, V, W and other terminals of the inverter output.</p> <p>2) The panel must be fixed and locked before power-on, so as to avoid personal safety damage due to defective internal capacitors and other components.</p> <p>3) After the power is turned on, wiring, inspection, etc. cannot be performed.</p> <p>4) After the device is powered on, do not touch the internal circuit board and its components to avoid the danger of electric shock.</p> <p>5) Turn off the power, and within 5 minutes after the keyboard display goes out, do not touch the circuit board and any parts in the machine, and you must use the instrument to confirm that the capacitors in the machine have been discharged before performing the operation in the machine, otherwise there will be electric shock. Danger.</p> <p>6) The static electricity of the human body will seriously damage the internal MOS field effect transistors, etc. If anti-static measures are not taken, do not touch the internal devices such as printed circuit boards and IGBTs with your hands, otherwise it may cause malfunctions.</p> <p>7) When using, the grounding terminal (E or <math>\perp</math>) of the inverter should be properly and reliably grounded according to the national electrical safety regulations and other relevant standards. Do not stop the machine by pulling the brake (power off), and cut off the power supply after the motor stops running.</p> <p>8) The optional input filter accessories must be added to meet the CE standard.</p> |

## 1-4. Scope of use

- ※ This inverter is only suitable for general industrial three-phase AC asynchronous motors.
- ※ This inverter can only be used in the occasions approved by our company. Unapproved use environment may cause fire, electric shock, explosion and other events.
- ※ If it is used in equipment that may cause personal injury or death due to inverter failure (for example: lifting equipment for transporting personnel, aviation systems, safety equipment, etc.), it must be handled with care. In this case, please consult the manufacturer.

### Use environment

- (1) Ambient temperature -10°C~40°C.
- (2) Prevent electromagnetic interference and stay away from interference sources.
- (3) Prevent the intrusion of water droplets, steam, dust, dust, cotton wool and fine metal powder.
- (4) Prevent the intrusion of oil, salt and corrosive gas.
- (5) Avoid vibration.
- (6) Avoid high temperature and humidity and no rain dripping, and the humidity is less than 90%RH (no condensation).
- (7) It is forbidden to use it in the dangerous environment of flammable, combustible, explosive gas, liquid or solid.

**Only trained personnel are allowed to operate this device, please read the safety, installation, operation and maintenance sections of this manual carefully before use.**

**The safe operation of this equipment depends on proper transport, installation, operation and maintenance!**

## Chapter 2: Standard Specifications

### 2-1. Technical Specifications

| Model         | Input voltage                                      | Output power<br>( KW ) | Input current<br>( A ) | Output current<br>( A ) | Match motor<br>KW |
|---------------|--|------------------------|------------------------|-------------------------|-------------------|
| DSI-100-K75G1 | Single-phase<br>AC220V±15<br>50/60Hz               | 0.75                   | 8.2                    | 4.0                     | 0.75              |
| DSI-100-1K5G1 |  | 1.5                    | 14.0                   | 7.0                     | 1.5               |
| DSI-100-2K2G1 |  | 2.2                    | 23.0                   | 9.6                     | 2.2               |
| DSI-100-K75G3 | Three-phase<br>AC380V~440V<br>-15%~+10%<br>50/60Hz | 0.75                   | 3.4                    | 2.3                     | 0.75              |
| DSI-100-1K5G3 |  | 1.5                    | 5.0                    | 3.7                     | 1.5               |
| DSI-100-2K2G3 |  | 2.2                    | 5.8                    | 5.0                     | 2.2               |
| DSI-100-004G3 |  | 3.7                    | 10.5                   | 9.0                     | 3.7               |
| DSI-100-5K5G3 |  | 5.5                    | 14.6                   | 13                      | 5.5               |

### 2-2 Standard specification

| Item                          |   | Specification   |
|-------------------------------|---|---|
| Basic<br>function             | Highest frequency   | Vector control: 0~500Hz;<br>V/F control: 0~500Hz  |
|                               | Carrier frequency   | 0.8kHz-12kHz the carrier frequency can be adjusted automatically according to the load characteristics. |
|                               | Input frequency resolution  | Digital setting: 0.01HZ<br>Analog setting: Maximum frequency × 0.025%                                   |
|                               | Control mode  | Open loop vector control (SVC) and V/F control  |
|                               | Start torque  | 0.5Hz/150% (SVC)  |
|                               | Speed range   | 1: 100 (SVC)  |
|                               | Speed control accuracy  | ±0.5% (SVC)   |
|                               | Overload capacity   | 150% rated current 60sec; 180% rated current 3sec   |
|                               | Torque boost  | Auto-torque boost; manual torque boost 0.1%~30.0%   |
|                               | V/F curve   | Three types: linear type; Multi-point type; the nth power of V/F curve                                  |
|                               | ACC/DEC curve   | Linear or S curve of ACC/DEC ways. Four types of ACC/DEC Time, ACC/DEC time range is 0.0~6500.0s        |
|                               | DC brake  | DC brake frequency: 0.00Hz~ max frequency, brake time: 0.0s~36.0s,brake action current: 0.0%~100.0%     |
|                               | JOG Control   | JOG frequency range: 0.00Hz~50.00Hz.<br>JOG speed-up/down time: 0.0s~6500.0.s                           |
| Simple PLC, multi-stage speed | Via built-in PLC or control terminal can realize max 16 stage speed running |   |

| Item                |                               | Specification  |
|---------------------|-------------------------------|--|
|                     | running                       |  |
|                     | Built-in PID                  | Can realize process control close-loop system conveniently   |
|                     | Auto-adjust voltage (AVR)     | When grid voltage changes, can keep output voltage steadily automatically  |
|                     | Over current and over         | During running, limit current and voltage automatically, protect from tripping off frequently for over voltage and over current.   |
|                     | Quick current-limit function  | Reduce over current error on max extent, protect inverter normal running   |
|                     | Torque limitation and control | “digger” feature, inverter could limit torque automatically, prevent over current tripping off;  |
| Personable function | Outstanding perform           | Using high-perform current vector control  |
|                     | Instance stop not stop        | During instant power-off, by motor feedback energy, inverter compensates voltage-drop to keep running for short time.  |
|                     | Quick current-limit function  | Reduce over current error on max extent  |
|                     | Timing control                | timing control function: setting time range: 0.0min~6500.0min  |
|                     | Command source                | control panel, control terminal, communication; can be switched by several modes   |
|                     | Frequency source              | digital setting, analog voltage setting, analog current setting, pulse setting, communication setting, can be switched by several methods  |
| Running             | Input terminal                | Standard:<br>5 digital input terminal, one of them support max 100KHz HS pulse input;<br>2 analog input terminal,<br>AI1 support 0~10V voltage input,<br>AI2 support 0~10V voltage or 0~20mA current |

| Item               |  | Specification  |
|--------------------|--|--|
|                    | Output terminal                          | Standard:<br>1 high-speed pulse output terminal(optional open collector),support 0~100kHz pulse<br>1 Relay output terminal<br>1 analog output support 0~10V voltage or 0~20mA current      |
| Display and keypad | LED display                              | Can display parameter  |
|                    | Press-key locking and function selection | Realize press-key partial or full locking, define part press-key function range, to avoid wrong operation  |
|                    | Protection function                      | Power-on motor short circuit test, output phase-loss protection, over-current protection, over-voltage protection, under-voltage protection, overheat protection, overload protection etc. |
| Environment        | Application site                         | Indoor, without direct sunlight, no powder, corrosive gas, combustion air, oil dust, water steam, water drop or salt etc.  |
|                    | Altitude level                           | Less than 1000m, Derating below 1000m, the rated output current is reduced by 1% for every 100m increase   |
|                    | Environment temperature                  | -10°C~+40°C (During 40°C~50°C, please reduce capacity use)   |
|                    | Humidity                                 | <95% RH, no water drop condensed   |

## 2-3. Sharp and Dimension

### 2-3-1. Product appearance drawing

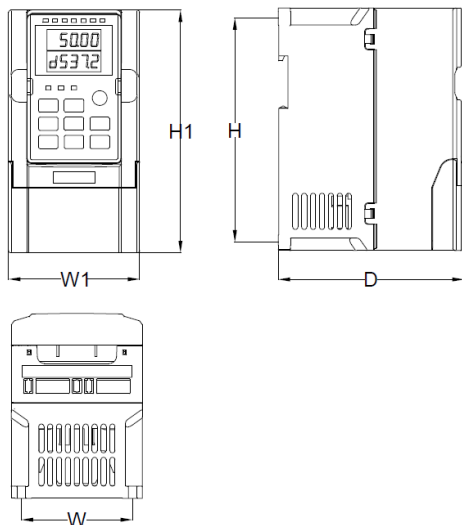

Figure 2-1 Product outline drawing and installation hole size

### 2-3-2. Installation hole size

| Model         | Outline Dimension (mm) |       |       |      |     |                  |        |
|---------------|------------------------|-------|-------|------|-----|------------------|--------|
|               | W                      | H     | D     | W1   | H1  | Mounting hole(d) | weight |
| DSI-100-K75G1 | 75                     | 151.5 | 125.5 | 88.5 | 164 | 5                | 0.9    |
| DSI-100-1K5G1 |                        |       |       |      |     |                  |        |
| DSI-100-2K2G1 |                        |       |       |      |     |                  |        |
| DSI-100-K75G3 |                        |       |       |      |     |                  |        |
| DSI-100-1K5G3 |                        |       |       |      |     |                  |        |
| DSI-100-2K2G3 |                        |       |       |      |     |                  |        |
| DSI-100-004G3 | 86                     | 170.5 | 136.5 | 97   | 184 | 5                | 1.3    |
| DSI-100-5K5G3 |                        |       |       |      |     |                  |        |

Figure 2-2 Product dimension and installation

### 2-3-3. Dimensions keyboard housing

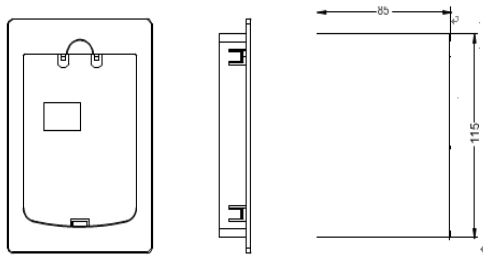



# Chapter 3: Installation and Circuits Diagram

## 3-1. Use environment

- (1) Ambient temperature  $-10^{\circ}\text{C}\sim 40^{\circ}\text{C}$ .
- (2) Prevent electromagnetic interference and stay away from interference sources.
- (3) Prevent the intrusion of water droplets, steam, dust, dust, cotton wool and fine metal powder.
- (4) Prevent the intrusion of oil, salt and corrosive gas.
- (5) Avoid vibration.
- (6) Avoid high temperature and humidity and no rain dripping, and the humidity is less than 90%RH (no condensation).
- (7) It is forbidden to use it in the dangerous environment of flammable, combustible, explosive gas, liquid or solid.

## 3-2 Wire diagram

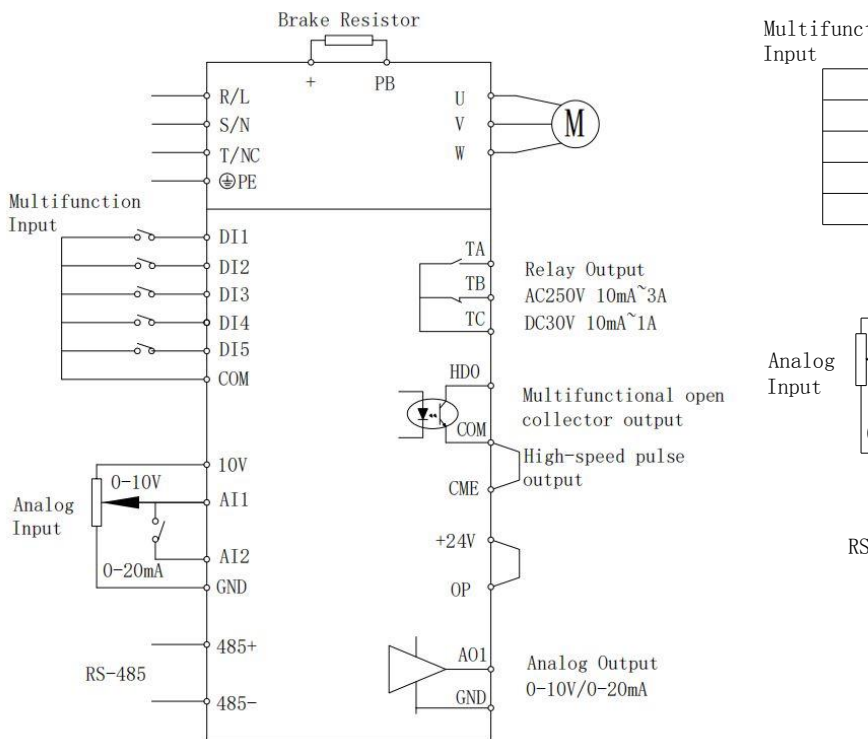
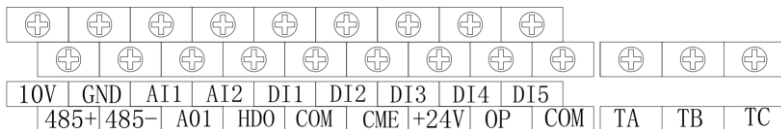

Figure 3-1 Wiring diagram

The inverter wiring is divided into two parts: the main circuit and the control circuit. The user must make the correct connection according to the wiring circuit shown in the figure above.

### 3-3. Control circuit terminal

#### 3-3-1 Control circuit terminal layout



#### 3-3-2. Control circuit terminal description

| Terminal | Description                          | Function   |
|----------|--------------------------------------|--|
| HDO-CME  | OC type DO                           | Optocoupler isolation, bipolar open collector output.<br>Output voltage range: 0-24V.<br>Output current range: 0-50mA.   |
| HDO-COM  | High-speed pulse output              | When used as high-speed pulse output, the maximum frequency is 100KHz.<br>Disconnect the COM and CME shorting jumper   |
| TA/TB/TC | Relay output                         | Contact drive capability:<br>AC250V, 3A, COSΦ=0.4DC30V, 1A<br>TC→TA is NO, TC→TB is NC   |
| 10V-GND  | +10V power supply                    | Provide 10V power supply to the outside, the maximum output current: 10mA<br>Generally used as an external potentiometer power supply, the potentiometer resistance range is 1KΩ-5KΩ                       |
| +24V-COM | +24V power supply                    | Provide +24V power supply to the outside, generally used as the working power supply of digital input and output terminals and external sensors<br>The maximum output current of the power supply: 200mA   |
| OP       | External power input                 | The factory default is connected with 24V,<br>When using external signals to drive DI1~DI5, the OP needs to be connected to the external power supply and disconnected from the +24V power supply terminal |
| DI1-OP   | DI1                                  | 1. Optocoupler isolation, compatible with bipolar input<br>2. Input impedance: 2.4kΩ<br>3. Voltage range for level input: 9V~30V   |
| DI2-OP   | DI2                                  |  |
| DI3-OP   | DI3                                  |  |
| DI4-OP   | DI4                                  |  |
| DI5-OP   | High-speed pulse input terminal      | In addition to the characteristics of DI1~DI4,<br>It can also be used as a high-speed pulse input channel.<br>Maximum input frequency: 100kHz  |
| AI1      | Multi-function analog input signal 1 | 1. Adjustable in the range of 0-10V.<br>2. The input impedance is 22kΩ, and the current input is 500Ω.   |
| AI2      | Multi-function analog input signal 2 | 1. JP2 1-2 short circuit: adjustable within the range of 0-10V.<br>2. JP2 2-3 short circuit: adjustable within the range of 0-20mA.<br>3. The input impedance is 22kΩ, and the current input is 500Ω.      |

|           |                              |   |
|-----------|------------------------------|---|
| AO1       | Multi-function analog output | 1. JP1 1-2 short circuit: adjustable within the range of 0-10V.<br>2. JP2 2-3 short circuit: adjustable within the range of 0-20mA. |
| 485+ 485- | RS-485                       | Standard RS485 communication interface, not isolated from GND, please use twisted pair or shielded wire                             |

### 3-4. Wiring Precautions

※It is not allowed to install phase-advancing capacitors or resistance-capacitance absorption devices at the U, V, W output ends of the inverter. When replacing the motor, the input power of the inverter must be cut off.

※Do not drop metal scraps or wire ends into the inverter when wiring, otherwise the inverter may malfunction.

※The motor can be switched or the industrial frequency power supply can be switched only when the inverter stops outputting.

※In order to minimize the influence of electromagnetic interference, when the electromagnetic contactor and Relay used are close to the inverter, it is necessary to consider installing a surge absorbing device.

※The external control line of the inverter must be equipped with an isolation device or a shielded line.

※In addition to shielding, the input command signal wiring should also be routed separately, preferably away from the main circuit wiring.

※When the carrier frequency is less than 3KHz, the maximum distance between the inverter and the motor should be within 50 meters; when the carrier frequency is greater than 4KHz, the distance should be appropriately reduced, and the wiring should be laid in a metal pipe.

※When the inverter is equipped with peripheral equipment (filters, reactors, etc.), first measure its insulation resistance to ground with a 1000-volt megohmmeter to ensure that it is not less than 4 megohms.

※When the inverter needs to be started frequently, do not turn off the power supply, and must use the control terminal or keyboard or RS485 running command to start and stop to avoid damage to the rectifier.

※Do not connect the AC input power supply to the output terminals U, V and W of the inverter.

※In order to prevent accidents, the ground terminal ( ) must be grounded reliably (the ground impedance should be below 100 ohms), otherwise there will be leakage.

※When the main circuit is wired, the selection of the wire diameter specification should be carried out in accordance with the relevant provisions of the national electrical regulations.

※The motor capacity should be equal to or smaller than the inverter capacity.

# Chapter 4: Operating Keyboard

## 4-1. Operation keyboard appearance

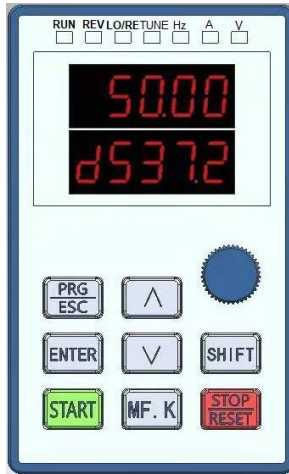

## 4-2. Introduction to Keyboard Indicators

| Indicator        |         | Indicator function                      | Indicator status  |
|------------------|---------|---|---|
| Unit indicator   | Hz      | Frequency                               | Always on: The current displayed number is the frequency  |
|                  | A       | Current                                 | Always on: The current displayed number is the current  |
|                  | V       | Voltage                                 | Always on: The current displayed number is the voltage  |
|                  | Hz+A    | Speed                                   | Both two lights are always on: the current display number is the speed  |
|                  | A+V     | Percentage                              | Steady on: The current displayed number is the percentage   |
| Status indicator | RUN     | Operating status                        | Always on: the inverter is running<br>Always off: the inverter is in stop state   |
|                  | LOCAL   | Run command mode                        | Always on: Terminal control mode<br>Blinking: Communication control mode<br>Always off: Operation panel control mode                                      |
|                  | FWD/REV | Forward/Reverse                         | Always on: the inverter is in the reverse state<br>Always off: the inverter is in the forward rotation state  |
|                  | TUNE    | Tuning, Torque Control, Fault Indicator | Steady on: the inverter is in torque control mode<br>Blinking slowly: the inverter is in tuning state<br>Flashing quickly: the inverter is in fault state |

A total of 5-digit LED display can display various monitoring data such as set frequency, output frequency, output current, output voltage, and alarm codes.

### 4-3. Operation panel key description

| Key        | Name                     | Function   |
|------------|--------------------------|--|
| PRG        | Program                  | Level 1 menu entry or exit   |
| ENTER      | Confirm                  | Enter the menu interface level by level, set parameters to confirm   |
| ⤴          | Increment                | Increment of data or function code   |
| ⤵          | Decrement                | Decrement of data or function code   |
| SHIFT      | Shift                    | In the stop display interface and the running display interface, the display parameters can be selected cyclically; when modifying the parameters, the modification bits of the parameters can be selected                     |
| RUN        | RUN                      | In keyboard operation mode, used to run operation  |
| MF.K       | Multi-function selection | According to 08-01 for function switch selection, it can be defined as command source, or direction quick switch   |
| STOP/RESET | Stop/Reset               | In the running state, pressing this key can be used to stop the running operation; in the fault alarm state, it can be used to reset the operation. The characteristics of this key are restricted by the function code 08-02. |

## Chapter 5: Summary of function parameters

The parameter menu in the user-defined parameter mode is not password protected. Group 0 is the basic function parameters, monitoring function parameters.

The symbols in the function table are explained as follows:

"◇": Indicates that the set value of this parameter can be changed when the inverter is in stop or running state;

"□": Indicates that the set value of this parameter cannot be changed when the inverter is running;

"■": Indicates that the value of this parameter is the actual detection record value and cannot be changed;

"\*": Indicates that the parameter is a "manufacturer parameter", which is limited to the manufacturers Settings, and the user is prohibited from operating

### Group 00 Monitoring Function Group

| Para. No. | Para. Name                                      | Display Range       | Modify | COM Add. |
|-----------|---|---------------------|--------|----------|
| 00.00     | Running frequency                               | 0-500.00Hz          | ■      | 7000     |
| 00.01     | Frequency reference                             | 0-500.00Hz          | ■      | 7001     |
| 00.02     | Bus voltage                                     | 0-3000V             | ■      | 7002     |
| 00.03     | Output voltage                                  | 0-1140V             | ■      | 7003     |
| 00.04     | Output current                                  | 0-655.35A           | ■      | 7004     |
| 00.05     | Output power                                    | 0-32767KW           | ■      | 7005     |
| 00.06     | Output torque                                   | -200.0%-200.0%      | ■      | 7006     |
| 00.07     | DI state  | 0-32767             | ■      | 7007     |
| 00.08     | DO state  | 0-1023              | ■      | 7008     |
| 00.09     | AI1 voltage                                     | 0-10.57V/0-20.000m  | ■      | 7009     |
| 00.10     | AI2 voltage/current                             | 0-10.57V/0-20.000m  | ■      | 700A     |
| 00.12     | Count value                                     | 0-65535             | ■      | 700C     |
| 00.13     | length value                                    | 0-65535             | ■      | 700D     |
| 00.14     | Load speed display                              | 0-65535             | ■      | 700E     |
| 00.15     | PID reference                                   | 0-100.0Bar          | ■      | 700F     |
| 00.16     | PID feedback                                    | 0-100.0Bar          | ■      | 7010     |
| 00.17     | PLC stage                                       | 0-16                | ■      | 7011     |
| 00.18     | Pulse reference                                 | 0-100.00KHz         | ■      | 7012     |
| 00.19     | feedback speed                                  | -500.00Hz-500.00Hz  | ■      | 7013     |
| 00.20     | Remaining running time                          | 0-65535Min          | ■      | 7014     |
| 00.21     | AI1 voltage before correction                   | 0-10.57V/0-20.000mA | ■      | 7015     |
| 00.22     | AI2 voltage (V)/ current (MA) before correction | 0-10.57V/0-20.000mA | ■      | 7016     |

| Para. No. | Para. Name                         | Display Range         | Modify | COM Add. |
|-----------|------------------------------------|-----------------------|--------|----------|
| 00.24     | Motor speed                        | 0-65535m/Min          | ■      | 7018     |
| 00.25     | Accumulative power-on time         | 0-65535Min            | ■      | 7019     |
| 00.26     | Accumulative running time          | 0-65535Min            | ■      | 701A     |
| 00.27     | Pulse reference                    | 0-65535Hz             | ■      | 701B     |
| 00.28     | Communication reference            | -100.0%-100.0%        | ■      | 701C     |
| 00.30     | Main frequency A reference         | 0-500.00Hz            | ■      | 701E     |
| 00.31     | Auxiliary frequency B reference    | 0-500.00Hz            | ■      | 701F     |
| 00.32     | Viewing any register address value | -                     | ■      | 7020     |
| 00.35     | Motor temperature                  | -200.0%-200.0%        | ■      | 7023     |
| 00.37     | Target torque                      | -                     | ■      | 7025     |
| 00.39     | Target voltage upon V/F separation | 0-Motor rated voltage | ■      | 7027     |
| 00.40     | Output voltage upon V/F separation | 0-Motor rated voltage | ■      | 7028     |
| 00.41     | S state display                    | -                     | ■      | 7029     |
| 00.42     | HDO state display                  | -                     | ■      | 702A     |
| 00.43     | S set for function state display 1 | -                     | ■      | 702B     |
| 00.44     | S set for function state display 2 | -                     | ■      | 702C     |
| 00.45     | fault information                  | -                     | ■      | 702D     |
| 00.59     | Frequency Reference                | -100.00%-100.00%      | ■      | 703B     |
| 00.60     | Running frequency                  | -100.00%-100.00%      | ■      | 703C     |
| 00.61     | AC drive state                     | 0-65535               | ■      | 703D     |
| 00.62     | Current fault code                 | 0-99                  | ■      | 703E     |

### Group 01 Basic Function Group

| Para. No. | Para. Name               | Setting Range  | Default | Modify | COM Add. |
|-----------|--------------------------|--|---------|--------|----------|
| 01.01     | Motor 1 control mode     | 0: Sensor-less vector control (SVC)<br>1: Reserved<br>2: V/F control | 2       | □      | F001     |
| 01.02     | Command source selection | 0: Operation panel<br>1: Terminal<br>2: Communication                | 0       | ◇      | F002     |



| Para. No. | Para. Name  | Setting Range   | Default | Modify                   | COM Add. |
|-----------|---|---|---------|--------------------------|----------|
| 01.03     | Main frequency reference setting X channel selection    | 0:digital setting (preset frequency 01.08, UP / DOWN can be modified, power is not memory)<br>1:digital setting (preset frequency 01.08, UP / DOWN can be modified, power-down memory)<br>2: AI1<br>3: AI2<br>4: AI3(Keyboard potentiometer)<br>5:High-speed pulse input setting (DI5)<br>6: Multi-segment instructions<br>7: Simple PLC<br>8: PID<br>9: communication given<br>10: Reserved  | 4       | <input type="checkbox"/> | F003     |
| 01.04     | Auxiliary frequency source Y command input selection    | Same as 01.03 (main frequency source A instruction input selection)   | 0       | <input type="checkbox"/> | F004     |
| 01.05     | Auxiliary frequency source Y Reference object selection | 0: relative to maximum frequency<br>1: Relative to frequency source X   | 0       | <input type="checkbox"/> | F005     |
| 01.06     | Auxiliary frequency source Y command range              | 0% ~ 150%   | 100%    | <input type="checkbox"/> | F006     |
| 01.07     | Frequency source combination mode selection             | Bit: frequency source selection<br>0: Main frequency source X<br>1: main and auxiliary operation results (operation relationship determined by ten)<br>2: Main frequency source X and auxiliary frequency source Y switch<br>3: Main frequency source X and master and slave operation result switching<br>4: auxiliary frequency source Y and master and slave operation result switching<br>Ten: frequency source main and auxiliary operation relationship<br>0: main + auxiliary<br>1: main - auxiliary<br>2: the two maximum<br>3: the two minimum | 00      | <input type="checkbox"/> | F007     |
| 01.08     | Preset frequency  | 0.00Hz~max frequency (01.10)  | 50.00Hz | <input type="checkbox"/> | F008     |

| Para. No. | Para. Name   | Setting Range   | Default          | Modify | COM Add. |
|-----------|--|---|------------------|--------|----------|
| 01.09     | Running direction  | 0:Same direction<br>1:Opposite direction  | 0                | ◇      | F009     |
| 01.10     | Max. frequency   | 50.00Hz~500.00Hz  | 50.00Hz          | □      | F00A     |
| 01.11     | Setting channel of frequency upper limit   | 0: 01.12 is set<br>1: AI1<br>2: AI2<br>3:AI3 (Keyboard potentiometer)<br>4:High-speed pulse setting (DI5)<br>5: Communication given | 0                | □      | F00B     |
| 01.12     | Frequency reference upper limit  | Lower limit 01.14~max frequency 01.10   | 50.00Hz          | ◇      | F00C     |
| 01.13     | Frequency reference upper limit offset   | 0.00Hz~max frequency 01.10  | 0.00Hz           | ◇      | F00D     |
| 01.14     | Frequency reference lower limit  | 0.00Hz to frequency upper limit 01.12   | 0.00Hz           | ◇      | F00E     |
| 01.15     | Carrier frequency  | 0.8kHz~12.0kHz  | Model determined | ◇      | F00F     |
| 01.16     | Carrier frequency adjusted with temperature  | 0: No<br>1: Yes   | 1                | ◇      | F010     |
| 01.17     | Acceleration time 1  | 0.00s~65000s *01.19   | Model determined | ◇      | F011     |
| 01.18     | Deceleration time 1  | 0.00s~65000s *01.19   | Model determined | ◇      | F012     |
| 01.19     | Acceleration /Deceleration time unit   | 0: 1s<br>1: 0.1s<br>2: 0.01s  | 1                | □      | F013     |
| 01.20     | Power-on automatic running delay time setting  | 0.0s~3600.0s  | Model determined | ◇      | F014     |
| 01.21     | Frequency offset of Auxiliary frequency setting channel for main and auxiliary calculation | 0.00Hz~max frequency 01.10  | 0.00Hz           | ◇      | F015     |
| 01.22     | Frequency reference  | 1: 0.1Hz<br>2: 0.01Hz   | 2                | □      | F016     |

| Para. No. | Para. Name  | Setting Range  | Default | Modify | COM Add. |
|-----------|---|--|---------|--------|----------|
|           | resolution  |  |         |        |          |
| 01.23     | Retentive of digital setting frequency upon stop                          | 0: No memory<br>1: Memory  | 1       | ◇      | F017     |
| 01.24     | Motor parameter group selection   | 0: 1st motor parameter<br>1: Reserved  | 0       | □      | F018     |
| 01.25     | Acceleration /Deceleration time base frequency                            | 0: Maximum frequency (01.10)<br>1: Set frequency<br>2: 100Hz   | 0       | □      | F019     |
| 01.26     | Base frequency for UP/DOW modification during running                     | 0: Run frequency<br>1: Set frequency   | 1       | □      | F01A     |
| 01.27     | The run command is tied to the main frequency source X command selection: | Bit: Operation panel command Bind frequency source selection<br>0: no binding<br>1: Digital setting frequency<br>2: AI1<br>3: AI2<br>4: AI3 (Keyboard potentiometer)<br>5: High-speed pulse input setting (DI5)<br>6: multi-speed<br>7: Simple PLC<br>8: PID<br>9: communication given<br>Ten: Terminal Command Binding Frequency Source Selection<br>Hundreds: communication command binding frequency source selection | 0000    | ◇      | F01B     |

### Group 02 1st Motor Parameters

| Para. No. | Para. Name           | Setting Range   | Default          | Modify | COM Add. |
|-----------|----------------------|---|------------------|--------|----------|
| 02.00     | Motor type selection | 0: Ordinary asynchronous motor<br>1: Variable frequency asynchronous motor<br>2: Reserved | 0                | □      | F100     |
| 02.01     | Rated motor power    | 0.1KW~1000.0KW  | Model determined | □      | F101     |
| 02.02     | Rated motor voltage  | 1V~2000V  | Model determined | □      | F102     |

| Para. No. | Para. Name                         | Setting Range   | Default               | Modify                   | COM Add. |
|-----------|------------------------------------|---|-----------------------|--------------------------|----------|
| 02.03     | Rated motor current                | 0.01A~655.35A<br>(Inverter power<=55KW)<br>0.1A~6553.5A<br>(Inverter power>55KW)  | Model determined      | <input type="checkbox"/> | F103     |
| 02.04     | Rated motor frequency              | 0.01Hz~Max frequency  | Model determined      | <input type="checkbox"/> | F104     |
| 02.05     | Rated motor speed                  | 1rpm~65535rpm   | Model determined      | <input type="checkbox"/> | F105     |
| 02.06     | Stator resistance                  | 0.001Ω~65.535Ω<br>(Inverter power<=55KW)<br>0.0001Ω~6.5535Ω<br>(Inverter power>55KW)  | Auto-tuning dependent | <input type="checkbox"/> | F106     |
| 02.07     | Rotor resistance                   | 0.001Ω~65.535Ω<br>(Inverter power<=55KW)<br>0.0001Ω~6.5535Ω<br>(Inverter power>55KW)  | Auto-tuning dependent | <input type="checkbox"/> | F107     |
| 02.08     | Leakage inductive reactance        | 0.01mH~655.35mH<br>(Inverter power<=55KW)<br>0.001mH~65.535mH<br>(Inverter power>55KW)  | Auto-tuning dependent | <input type="checkbox"/> | F108     |
| 02.09     | Mutual inductive                   | 0.1mH~6553.5mH<br>(Inverter power<=55KW)<br>0.01mH~655.35mH<br>(Inverter power>55KW)  | Auto-tuning dependent | <input type="checkbox"/> | F109     |
| 02.10     | No-load current                    | 0.01A~02.03<br>(Inverter power<=55KW)<br>0.1A~02.03<br>(Inverter power>55KW)  | Auto-tuning dependent | <input type="checkbox"/> | F10A     |
| 02.37     | Motor auto-tuning method selection | 0: no operation<br>1:Asynchronous machine static part of the parameters of self-learning<br>2:asynchronous machine dynamic complete self-learning<br>3:asynchronous machine static complete self-learning | 0                     | <input type="checkbox"/> | F125     |

### Group 03 the motor vector control parameters

| Para. No. | Para. Name                                       | Setting Range   | Default | Modify | COM Add. |
|-----------|--|---|---------|--------|----------|
| 03.00     | Speed loop proportional gain1                    | 1~100   | 30      | ◇      | F200     |
| 03.01     | Speed loop integral time 1                       | 0.01s~10.00s  | 0.50s   | ◇      | F201     |
| 03.02     | Switch over frequency 1                          | 0.00~03.05  | 5.00Hz  | ◇      | F202     |
| 03.03     | Speed loop proportional gain 2                   | 1~100   | 20      | ◇      | F203     |
| 03.04     | Speed loop integral time 2                       | 0.01s~10.00s  | 1.00s   | ◇      | F204     |
| 03.05     | Switch over frequency 2                          | 03.02~Max frequency(01.10)  | 10.00Hz | ◇      | F205     |
| 03.06     | SVC slip compensation gain                       | 50%~200%  | 100%    | ◇      | F206     |
| 03.07     | SVC Speed feedback filter time constant          | 0.000s~0.100s   | 0.015s  | ◇      | F207     |
| 03.08     | Torque limit source in speed control             | 0~200   | 64      | ◇      | F208     |
| 03.09     | Digital setting of torque limit in speed control | 0: Function code 03.10 setting<br>1: AI1<br>2: AI2<br>3: AI3(keyboard potentiometer)<br>4: High-speed pulse input setting (DI5)<br>5: Communication given<br>6: MIN (AI1, AI2)<br>7: MAX (AI1, AI2)<br>1-7 option full scale corresponds to 03.10 | 0       | ◇      | F209     |
| 03.10     | Speed loop proportional gain1                    | 0.0%~200.0%   | 150.0%  | ◇      | F20A     |
| 03.13     | Excitation adjustment proportional gain          | 0~60000   | 2000    | ◇      | F20D     |
| 03.14     | Excitation adjustment integral gain              | 0~60000   | 1300    | ◇      | F20E     |
| 03.15     | Torque adjustment proportional gain              | 0~60000   | 2000    | ◇      | F20F     |
| 03.16     | Torque adjustment integral gain                  | 0~60000   | 1300    | ◇      | F210     |

### Group 04 V/F Control Parameters

| Para. No. | Para. Name                        | Setting Range  | Default          | Modify | COM Add. |
|-----------|-----------------------------------|--|------------------|--------|----------|
| 04.00     | V/F curve setting                 | 0: Straight line V / F<br>1: Multi-point V / F<br>2: Square V / F<br>3: 1.2 Power V / F<br>4: 1.4 Power V / F<br>6: 1.6 Power V / F<br>8: 1.8 power V / F<br>9: Reserved<br>10: VF complete separation mode<br>11: VF semi-separation mode   | 0                | □      | F300     |
| 04.01     | Torque boost                      | 0.0%: (Ineffective)<br>0.1%~30.0%  | 0.0%             | ◇      | F301     |
| 04.02     | Cut-off frequency of torque boost | 0.00Hz~max frequency   | 50.00Hz          | □      | F302     |
| 04.03     | Multi-point V/F frequency 1       | 0.00Hz~04.05   | 0.00Hz           | □      | F303     |
| 04.04     | Multi-point V/F voltage 1         | 0.0%~100.0%  | 0.0%             | □      | F304     |
| 04.05     | Multi-point V/F frequency 2       | 04.03~04.07  | 0.00Hz           | □      | F305     |
| 04.06     | Multi-point V/F voltage 2         | 0.0%~100.0%  | 0.0%             | □      | F306     |
| 04.07     | Multi-point V/F frequency 3       | 04.05~motor rated frequency (02.04)  | 0.00Hz           | □      | F307     |
| 04.08     | Multi-point V/F voltage 3         | 0.0%~100.0%  | 0.0%             | □      | F308     |
| 04.09     | V/F Slip compensation gain        | -  | 100.0%           | ◇      | F309     |
| 04.10     | V/F over-excitation gain          | 0~200  | 64               | ◇      | F30A     |
| 04.11     | V/F oscillation suppression gain  | 0~100  | Model determined | ◇      | F30B     |
| 04.13     | Voltage source for V/F separation | 0: digital setting (04.14)<br>1: AI1 (Note: J6 jumper)<br>2: AI2<br>3: AI3(keyboard potentiometer)<br>4: High-speed pulse input setting (DI5)<br>5: Multi-segment instructions<br>6: Simple PLC<br>7: PID<br>8: Communication given<br>Note: 100.0% corresponds to the motor rated voltage | 0                | ◇      | F30D     |
| 04.14     | Digital setting of                | 0V~motor rated voltage   | 0V               | ◇      | F30E     |

| Para. No. | Para. Name   | Setting Range   | Default                        | Modify | COM Add. |
|-----------|--|---|--------------------------------|--------|----------|
|           | voltage for V/F separation                                   |   |                                |        |          |
| 04.15     | Voltage rise time of V/F separation                          | 0.0s~1000.0s<br>Note: 0V to rated motor voltage   | 0.0s                           | ◇      | F30F     |
| 04.16     | Voltage decline time of V/F separation                       | 0.0s~1000.0s<br>Note: time of 0v to rated motor voltage   | 0.0s                           | ◇      | F310     |
| 04.17     | Stop mode selection for V/F separation                       | 0: Frequency/voltage is reduced to 0 independently<br>1: The frequency starts to drop after the voltage is reduced to 0 | 0                              | ◇      | F311     |
| 04.19     | Current limit selection                                      | 0: Useless<br>1: Useful   | 1                              | ◇      | F313     |
| 04.20     | Current limit gain   | 0~100   | 20                             | ◇      | F314     |
| 04.21     | Compensation factor of speed multiplying current limit level | 50~200%   | 50%                            | ◇      | F315     |
| 04.22     | Voltage limit  | 650V~800.0V   | 220V :<br>380V<br>380:<br>760V | ◇      | F316     |
| 04.23     | Voltage limit selection                                      | 0: Useless<br>1: Useful   | 1                              | ◇      | F317     |
| 04.24     | Frequency gain for voltage limit                             | 0~100   | 30                             | ◇      | F318     |
| 04.25     | Voltage gain for voltage limit                               | 0~100   | 30                             | ◇      | F319     |
| 04.26     | Frequency rise threshold during voltage limit                | 0~50Hz  | 5Hz                            | ◇      | F31A     |
| 04.27     | Slip Compensation Time Constant                              | 0.1-10.0s   | 0.5s                           | ◇      | F31B     |

### Group 05 Input Terminals

| Para. No. | Para. Name             | Setting Range   | Default | Modify | COM Add. |
|-----------|------------------------|---|---------|--------|----------|
| 05.00     | DI1 function selection | 0: No function<br>1: Forward RUN (FWD)<br>2: Reverse RUN (REV)<br>3: Three-line control<br>4: Forward JOG (FJOG)<br>5: Reverse JOG (RJOG)<br>6: Terminal UP<br>7: Terminal DOWN | 1       | □      | F400     |
| 05.01     | DI2 functions election |   | 2       | □      | F401     |
| 05.02     | DI3 functions election |   | 8       | □      | F402     |
| 05.03     | DI4 functions election |   | 9       | □      | F403     |
| 05.04     | DI5 functions election |   | 12      | □      | F404     |
|           |                        |   |         |        |          |

| Para. No. | Para. Name     | Setting Range   | Default | Modify                   | COM Add. |
|-----------|----------------|---|---------|--------------------------|----------|
| 05.05     | Reserved       | 8: Coast to stop  | 13      | <input type="checkbox"/> | F405     |
| 05.06     | Reserved       | 9: Fault reset (RESET)<br>10: RUN pause   | 0       | <input type="checkbox"/> | F406     |
| 05.07     | Reserved       | 11: Normally open input of external fault<br>12: Multi-reference terminal 1   | 0       | <input type="checkbox"/> | F407     |
| 05.08     | Reserved       | 13: Multi-reference terminal 2<br>14: Multi-reference terminal 3<br>15: Multi-reference terminal 4<br>16: Terminal 1 for acceleration/ deceleration time selection<br>17: Terminal 2 for ACC/DEC time selection<br>18: Frequency source switchover<br>19: UP and DOWN setting clear (terminal, operation panel)<br>20: Command source switchover terminal 1<br>21: Acceleration/Deceleration prohibited<br>22: PID pause<br>23: PLC status reset<br>24: Swing pause<br>25: Counter input<br>26: Counter reset<br>27: Length count input<br>28: Length reset<br>29: Reserved<br>30: Pulse input (enabled only for DI5)<br>31:Reserved  | 0       | <input type="checkbox"/> | F408     |
| 05.09     | Reserved       | 32: Immediate DC braking<br>33: Normally closed input of external fault<br>34: Frequency modification forbidden<br>35: Reverse PID action direction<br>36: External STOP terminal 1<br>37: Command source switchover terminal 2<br>38: PID integral pause<br>39: Switchover between main frequency source X and preset frequency<br>40: Switchover between auxiliary frequency source Y and preset frequency<br>41: Reserved<br>42: Reserved<br>43: PID parameter switchover<br>44: User-defined fault 1<br>45: User-defined fault 2<br>46: Reserved<br>47: Emergency stop<br>48: External STOP terminal 2<br>49: Deceleration DC braking<br>50: Clear the current running time<br>51: Run terminal below the forced under voltage point<br>52: Deceleration stop function, JOG is valid<br>53-59: Reserved | —       | <input type="checkbox"/> | F409     |
| 05.10     | DI filter time | 0.000– 1.000s   | 0.010s  | <input type="checkbox"/> | F40A     |



| Para. No. | Para. Name  | Setting Range  | Default  | Modify                   | COM Add. |
|-----------|---|--|----------|--------------------------|----------|
| 05.11     | Terminal command mode                             | 0: Two-line mode 1<br>1: Two-line mode 2<br>2: Three-line mode 1<br>3: Three-line mode 2 | 0        | <input type="checkbox"/> | F40B     |
| 05.12     | Terminal UP/DOWN rate                             | 0.01~65.535 Hz/s   | 1.00Hz/s | ◇                        | F40C     |
| 05.13     | AI curve 1 minimum input                          | 0.00V to 05.15   | 0.00V    | ◇                        | F40D     |
| 05.14     | Corresponding setting of AI curve 1 minimum input | -100.0% ~+100.0%   | 0.0%     | ◇                        | F40E     |
| 05.15     | AI curve 1 maximum input                          | 05.13~+10.00V  | 10.00V   | ◇                        | F40F     |
| 05.16     | Corresponding setting of AI curve 1               | -100.0% ~+100.0%   | 100.0%   | ◇                        | F410     |
| 05.17     | AI1 filter time                                   | 0.00s~10.00s   | 0.10s    | ◇                        | F411     |
| 05.18     | AI curve 2 minimum input                          | 0.00V~05.20  | 0.00V    | ◇                        | F412     |
| 05.19     | Corresponding setting of AI curve 2 minimum input | -100.0% ~+100.0%   | 0.0%     | ◇                        | F413     |
| 05.20     | AI curve 2 maximum input                          | 05.18~+10.00V  | 10.00V   | ◇                        | F414     |
| 05.21     | Corresponding setting of AI curve 2 maximum input | -100.0% ~+100.0%   | 100.0%   | ◇                        | F415     |
| 05.22     | AI2 filter time                                   | 0.00s~10.00s   | 0.10s    | ◇                        | F416     |
| 05.28     | Pulse minimum input                               | 0.00kHz~05.30  | 0.00KHz  | ◇                        | F41C     |
| 05.29     | Corresponding setting of pulse minimum input      | -100.0% ~100.0%  | 0.0%     | ◇                        | F41D     |
| 05.30     | Pulse maximum input                               | 05.28~100.00KHz  | 50.00KHz | ◇                        | F41E     |
| 05.31     | Corresponding setting of pulse maximum input      | -100.0% ~100.0%  | 100.0%   | ◇                        | F41F     |
| 05.32     | Pulse filter time                                 | 0.00s~10.00s   | 0.10s    | ◇                        | F420     |

| Para. No. | Para. Name                                     | Setting Range  | Default | Modify | COM Add. |
|-----------|--|--|---------|--------|----------|
| 05.33     | AI curve selection                             | Bit: AI1 curve selection<br>1: curve 1 (2 points, see 05.13 ~ 05.16)<br>2: Curve 2 (2 points, see 05.18 ~ 05.21)<br>3: curve 3 (2 points, see 05.23 ~ 05.26)<br>4: curve 4 (4 points, see 24.00 ~ 24.07)<br>5: curve 5 (4 points, see 24.08 ~ 24.15)<br>Ten: AI2 curve selection, as above<br>Hundreds: Reserved | 321     | ◇      | F421     |
| 05.34     | Setting selection when AI less than min. input | Bit: AI1 is lower than the minimum input setting<br>0: corresponds to the minimum input setting<br>1: 0.0%<br>Ten: AI2 is lower than the minimum input setting, as above<br>Hundreds: Reserved   | 000     | ◇      | F422     |
| 05.35     | DI1 delay time                                 | 0.0s~3600.0s   | 0.0s    | □      | F423     |
| 05.36     | DI2 delay time                                 | 0.0s~3600.0s   | 0.0s    | □      | F424     |
| 05.37     | DI3 delay time                                 | 0.0s~3600.0s   | 0.0s    | □      | F425     |
| 05.38     | DI terminal valid mode selection 1 (DI1~DI5)   | 0: High level valid<br>1: Low level valid<br>Bit: DI1<br>Ten's digit: DI2<br>Hundred's digit: DI3<br>Thousands of bits: DI4<br>Ten thousands of bits: DI5  | 00000   | □      | F426     |
| 05.39     | DI terminal valid mode selection 2             | 0: High level valid<br>1: Low level valid<br>Bit: Reserved<br>Ten's digit: Reserved<br>Hundred's digit: Reserved<br>Thousands of bits: Reserved<br>Ten thousands of bits: Reserved   | 00000   | □      | F427     |

### Group 06 Output Terminals

| Para. No. | Para. Name   | Setting Range   | Default | Modify | COM Add. |
|-----------|--|---|---------|--------|----------|
| 06.00     | HDO terminal output mode                               | 0: Pulse output<br>1: Digital output  | 0       | ◇      | F500     |
| 06.01     | HDO terminal function (open-collector output terminal) | 0: No output<br>1: AC drive running<br>2: Fault output (stop)<br>3: Frequency-level detection FDT1 output<br>4: Frequency reached<br>5: Zero-speed running (no output at stop)<br>6: Motor overload pre-warning<br>7: AC drive overload pre-warning | 0       | ◇      | F501     |
| 06.02     | Relay output (TA-TB-TC)                                | 8: Set count value reached<br>9: Designated count value reached   | 2       | ◇      | F502     |

| Para. No. | Para. Name   | Setting Range  | Default | Modify | COM Add. |
|-----------|--|--|---------|--------|----------|
|           |  | 10: Length reached<br>11: PLC cycle complete<br>12: Accumulative running time reached<br>13: Frequency limited<br>14: Torque limited<br>15: Ready for RUN<br>16: AI1 larger than AI2<br>17: Frequency upper limit reached<br>18: Frequency lower limit reached (no output at stop)<br>19: Under voltage state output<br>20: Communication setting<br>21: Reserved<br>22: Reserved<br>23: Zero-speed running 2 (having output at stop)<br>24: Accumulative power-on time reached<br>25: Frequency level detection FDT2 output<br>26: Frequency 1 reached<br>27: Frequency 2 reached<br>28: Current 1 reached<br>29: Current 2 reached<br>30: Timing reached<br>31: AI1 input limit exceeded<br>32: Load becoming 0<br>33: Reverse running<br>34: Zero current state<br>35: Module temperature reached<br>36: Software current limit exceeded<br>37: Frequency lower limit reached (having output at stop)<br>38: Alarm output<br>39: Motor overheat warning<br>40: Current running time reached<br>41: Fault output<br>42: Forward running<br>43: One-to-two control<br>44: High pressure arrives<br>45: Low pressure arrives |         |        |          |
| 06.06     | HDO terminal function (High speed pulse output terminal) | 0: Running frequency<br>1: Set frequency<br>2: Output current<br>3: Output torque<br>4: Output power<br>5: Output voltage<br>6: Pulse input(100% corresponds to 100.0KHz)<br>7: AI1<br>8: AI2<br>9: AI3<br>10: Length<br>11: Count value<br>12: Communication setting  | 0       | ◇      | F506     |

| Para. No. | Para. Name                        | Setting Range   | Default  | Modify | COM Add. |
|-----------|-----------------------------------|---|----------|--------|----------|
| 06.07     | AO1 output function selection     | 13: Motor speed<br>14: Output current (100.0% corresponds to 1000.0A)<br>15: Output voltage (100.0% corresponds to 1000.0V)<br>16: Motor output torque (actual value, percentage relative to motor) | 0        | ◇      | F507     |
| 06.09     | Maximum HDO output frequency      | 0.01KHz~100.00KHz   | 50.00KHz | ◇      | F509     |
| 06.10     | AO1 offset coefficient            | -100.0%~+100.0%   | 0.0%     | ◇      | F50A     |
| 06.11     | AO1 gain                          | -10.00~+10.00   | 1.00     | ◇      | F50B     |
| 06.14     | AO1 filter time                   | 0.00s~10.00s  | 0.0s     | ◇      | F50E     |
| 06.16     | HDO filter time                   | 0.00s~10.00s  | 0.0s     | ◇      | F510     |
| 06.17     | HDO delay time                    | 0.0s~3600.0s  | 0.0s     | ◇      | F511     |
| 06.18     | Relay delay time                  | 0.0s~3600.0s  | 0.0s     | ◇      | F512     |
| 06.22     | DO terminal valid state selection | 0: High level valid<br>1: Low level valid<br>Bit: HDO<br>Ten's digit: TA1-TB1-TC1<br>Hundred's digit: Reserved<br>Thousands of bits: Reserved<br>Ten thousands of bits: Reserved                    | 00000    | ◇      | F516     |

### Group 07 Start/Stop Control

| Para. No. | Para. Name   | Setting Range  | Default | Modify | COM Add. |
|-----------|--|--|---------|--------|----------|
| 07.00     | Start mode   | 0: Direct start<br>1: Rotational speed tracking restart<br>2: Pre-excited start (asynchronous motor) | 0       | ◇      | F600     |
| 07.01     | Rotational speed tracking mode                     | 0: From frequency at stop<br>1: From zero speed<br>2: From maximum frequency                         | 0       | □      | F601     |
| 07.02     | Rotational speed tracking speed                    | 1- 100   | 20      | ◇      | F602     |
| 07.03     | Startup frequency                                  | 0.00- 10.00 Hz   | 0.00Hz  | ◇      | F603     |
| 07.04     | Startup frequency holding time                     | 0.0- 100.0s  | 0.0s    | □      | F604     |
| 07.05     | Startup DC braking current/<br>Pre-excited current | 0%- 100%   | 0%      | □      | F605     |
| 07.06     | Startup DC braking time/<br>Pre-excited time       | 0.0- 100.0s  | 0.0s    | □      | F606     |

| Para. No. | Para. Name                               | Setting Range   | Default | Modify                   | COM Add. |
|-----------|--|---|---------|--------------------------|----------|
| 07.07     | Acceleration/Deceleration mode           | 0: Linear acceleration/deceleration<br>1: S-curve acceleration/deceleration A<br>2: S-curve acceleration/deceleration B | 0       | <input type="checkbox"/> | F607     |
| 07.08     | Time proportion of S-curve start segment | 0.0% ~ ( 100.0%-07.09 )   | 30.0%   | <input type="checkbox"/> | F608     |
| 07.09     | Time proportion of S-curve end segment   | 0.0% ~ ( 100.0%-07.08 )   | 30.0%   | <input type="checkbox"/> | F609     |
| 07.10     | Stop mode                                | 0: Decelerate to stop<br>1: Coast to stop   | 0       | <input type="checkbox"/> | F60A     |
| 07.11     | Initial frequency of stop DC braking     | 0.00Hz~Max.frequency  | 0.00Hz  | <input type="checkbox"/> | F60B     |
| 07.12     | Waiting time of stop DC braking          | 0.0s~100.0s   | 0.0s    | <input type="checkbox"/> | F60C     |
| 07.13     | Stop DC braking current                  | 0%~100%   | 0%      | <input type="checkbox"/> | F60D     |
| 07.14     | Stop DC braking time                     | 0.0s~100.0s   | 0.0s    | <input type="checkbox"/> | F60E     |
| 07.15     | Brake use ratio                          | 0%~100%   | 100%    | <input type="checkbox"/> | F60F     |

### Group 08 Keyboard and Display

| Para. No. | Para. Name                       | Setting Range  | Default | Modify                   | COM Add. |
|-----------|----------------------------------|--|---------|--------------------------|----------|
| 08.01     | MF.K Key function selection      | 0: MF.K key disabled<br>1: Switchover between operation panel control and remote command control (terminal or communication)<br>2: Switchover between forward rotation and reverse rotation<br>3: Forward JOG<br>4: Reverse JOG<br>5: Reverse  | 3       | <input type="checkbox"/> | F700     |
| 08.02     | STOP/RESET key function          | 0: STOP/RESET key enabled only in operation panel control<br>1: STOP/RESET key enabled in any operation mode   | 1       | <input type="checkbox"/> | F701     |
| 08.03     | LED display running parameters 1 | 0000~FFFF<br>Bit00: Running frequency 1 (Hz)<br>Bit01: Set frequency (Hz)<br>Bit02: Bus voltage (V)<br>Bit03: Output voltage (V)<br>Bit04: Output current (A)<br>Bit05: Output power (kW)<br>Bit06: Output torque (%)<br>Bit07: DI input status<br>Bit08: DO output status<br>Bit09: AI1 voltage (V)<br>Bit10: AI2 voltage (V)<br>Bit11: AI3 voltage (V)<br>Bit12: Count value | 0xC01F  | <input type="checkbox"/> | F702     |

| Para. No. | Para. Name                              | Setting Range   | Default | Modify | COM Add. |
|-----------|---|---|---------|--------|----------|
|           |   | Bit13: Length value<br>Bit14: Load speed display<br>Bit15: PID setting  |         |        |          |
| 08.04     | LED display running parameters 2        | 0000~FFFF<br>Bit00: PID feedback<br>Bit01: PLC stage<br>Bit02: Pulse setting frequency (kHz)<br>Bit03: Running frequency 2 (Hz)<br>Bit04: Remaining running time<br>Bit05: AI1 voltage before correction (V)<br>Bit06: AI2 voltage before correction (V)<br>Bit07: Reserved<br>Bit08: Linear speed<br>Bit09: Current power-on time (Hour)<br>Bit10: Current running time (Min)<br>Bit11: Pulse setting frequency (Hz)<br>Bit12: Communication setting value<br>Bit13: Reserved<br>Bit14: Main frequency A display (Hz)<br>Bit15: Auxiliary frequency B display (Hz) | 0x01    | ◇      | F703     |
| 08.05     | LED stop display parameters             | 0000~FFFF<br>Bit00: Set frequency (Hz)<br>Bit01: Bus voltage (V)<br>Bit02: DI input status<br>Bit03: DO output status<br>Bit04: AI1 voltage (V)<br>Bit05: AI2 voltage (V)<br>Bit06: AI3 voltage (V)<br>Bit07: Count value<br>Bit08: Length value<br>Bit09: PLC stage<br>Bit10: Load speed<br>Bit11: PID setting<br>Bit12: Pulse setting frequency (kHz)   | 33      | ◇      | F704     |
| 08.06     | Load speed display coefficient          | 0.0001~6.5000   | 1.0000  | ◇      | F705     |
| 08.07     | Heatsink temperature of inverter module | 0.0°C~100.0°C   | -       | ■      | F706     |
| 08.08     | Temporary software version              | 0.0°C~100.0°C   | -       | ■      | F707     |
| 08.09     | Accumulative running time               | 0h~65535h   | -       | ■      | F708     |
| 08.10     | Product number                          | 300   | -       | ■      | F709     |
| 08.11     | Software version                        | -   | -       | ■      | F70A     |
| 08.12     | Number of decimal places for            | 0: 0 decimal places<br>1: 1 decimal place   | 0       | ◇      | F70B     |

| Para. No. | Para. Name                     | Setting Range                              | Default | Modify | COM Add. |
|-----------|--------------------------------|--|---------|--------|----------|
|           | load speed display             | 2: 2 decimal places<br>3: 3 decimal places |         |        |          |
| 08.13     | Accumulative power-on time     | 0h~65535h                                  | -       | ■      | F70C     |
| 08.14     | Accumulative power consumption | 0~65535Kw*h                                | -       | ■      | F70D     |

### Group 09 Auxiliary Functions

| Para. No. | Para. Name   | Setting Range  | Default          | Modify | COM Add. |
|-----------|--|--|------------------|--------|----------|
| 09.00     | JOG running frequency  | 0.00Hz~Max. frequency  | 2.00Hz           | ◇      | F800     |
| 09.01     | JOG acceleration time  | 0.0s~6500.0s   | 20.0s            | ◇      | F801     |
| 09.02     | JOG deceleration time  | 0.0s~6500.0s   | 20.0s            | ◇      | F802     |
| 09.03     | Acceleration time 2  | 0.0s~6500.0s   | Model determined | ◇      | F803     |
| 09.04     | Deceleration time 2  | 0.0s~6500.0s   | Model determined | ◇      | F804     |
| 09.05     | Acceleration time 3  | 0.0s~6500.0s   | Model determined | ◇      | F805     |
| 09.06     | Deceleration time 3  | 0.0s~6500.0s   | Model determined | ◇      | F806     |
| 09.07     | Acceleration time 4  | 0.0s~6500.0s   | Model determined | ◇      | F807     |
| 09.08     | Deceleration time 4  | 0.0s~6500.0s   | Model determined | ◇      | F808     |
| 09.09     | Jump frequency 1   | 0.00 Hz to maximum frequency                                       | 0.00Hz           | ◇      | F809     |
| 09.10     | Jump frequency 2   | 0.00 Hz to maximum frequency                                       | 0.00Hz           | ◇      | F80A     |
| 09.11     | Frequency jump amplitude   | 0.00 Hz to maximum frequency                                       | 0.00Hz           | ◇      | F80B     |
| 09.12     | Forward/Reverse rotation dead-zone time                          | 0.0~3000.0s  | 0.0s             | ◇      | F80C     |
| 09.13     | Reverse control  | 0: Enabled<br>1: Disabled  | 0                | ◇      | F80D     |
| 09.14     | Running mode when set frequency lower than frequency lower limit | 0: Run at frequency lower limit<br>1: Stop<br>2: Run at zero speed | 0                | ◇      | F80E     |

| Para. No. | Para. Name   | Setting Range                    | Default | Modify | COM Add. |
|-----------|--|----------------------------------|---------|--------|----------|
| 09.15     | Droop control  | 0.00– 10.00 Hz                   | 0.00Hz  | ◇      | F80F     |
| 09.16     | Accumulative power-on time threshold   | 0–65000 h                        | 0h      | ◇      | F810     |
| 09.17     | Accumulative running time threshold  | 0–65000 h                        | 0h      | ◇      | F811     |
| 09.18     | Startup protection   | 0: No<br>1: Yes                  | 1       | ◇      | F812     |
| 09.19     | Frequency detection value (FDT1)   | 0.00 Hz to maximum frequency     | 50.00Hz | ◇      | F813     |
| 09.20     | Frequency detection hysteresis (FDT hysteresis 1)                              | 0.0%– 100.0% (FDT1 level)        | 5.0%    | ◇      | F814     |
| 09.21     | Detection range of frequency reached   | 0.00– 100% (maximum frequency)   | 0.0%    | ◇      | F815     |
| 09.22     | Jump frequency during acceleration/deceleration                                | 0: Disabled<br>1: Enabled        | 0       | ◇      | F816     |
| 09.25     | Frequency switchover point between acceleration time 1 and acceleration time 2 | 0.00 Hz to maximum frequency     | 0.00Hz  | ◇      | F819     |
| 09.26     | Frequency switchover point between deceleration time 1 and deceleration time 2 | 0.00 to maximum frequency        | 0.00Hz  | ◇      | F81A     |
| 09.27     | Terminal JOG preferred   | 0: Disabled<br>1: Enabled        | 1       | ◇      | F81B     |
| 09.28     | Frequency detection value (FDT2)   | 0.00 to maximum frequency        | 50.00Hz | ◇      | F81C     |
| 09.29     | Frequency detection hysteresis (FDT hysteresis 2)                              | 0.0%– 100.0% (FDT2 level)        | 5.0%    | ◇      | F81D     |
| 09.30     | Any frequency reaching detection value 1                                       | 0.00 Hz to maximum frequency     | 50.00Hz | ◇      | F81E     |
| 09.31     | Any frequency reaching detection amplitude 1                                   | 0.0%– 100.0% (maximum frequency) | 0.0%    | ◇      | F81F     |
| 09.32     | Any frequency reaching detection value 2                                       | 0.00 Hz to maximum frequency     | 50.00Hz | ◇      | F820     |



| Para. No. | Para. Name                                   | Setting Range   | Default | Modify | COM Add. |
|-----------|--|---|---------|--------|----------|
| 09.33     | Any frequency reaching detection amplitude 2 | 0.0%– 100.0% (maximum frequency)  | 0.0%    | ◇      | F821     |
| 09.34     | Zero current detection level                 | 0.0%–300.0% (rated motor current)   | 5.0%    | ◇      | F822     |
| 09.35     | Zero current detection delay time            | 0.00–600.00s  | 0.10s   | ◇      | F823     |
| 09.36     | Output overcurrent threshold                 | 0.0% (no detection)<br>0.1%–300.0% (rated motor current)  | 200.0%  | ◇      | F824     |
| 09.37     | Output overcurrent detection delay time      | 0.00–600.00s  | 0.00s   | ◇      | F825     |
| 09.38     | Any current reaching 1                       | 0.0%–300.0% (rated motor current)   | 100.0%  | ◇      | F826     |
| 09.39     | Any current reaching 1 amplitude             | 0.0%–300.0% (rated motor current)   | 0.0%    | ◇      | F827     |
| 09.40     | Any current reaching 2                       | 0.0%–300.0% (rated motor current)   | 100.0%  | ◇      | F828     |
| 09.41     | Any current reaching 2 amplitude             | 0.0%–300.0% (rated motor current)   | 0.0%    | ◇      | F829     |
| 09.42     | Timing function                              | 0: Disabled<br>1: Enabled   | 0       | ◇      | F82A     |
| 09.43     | Timing duration source                       | 0: 09.44<br>1: AI1<br>2: AI2<br>3: Reserved<br>(100% of analog input corresponds to the value of 09.44) | 0       | ◇      | F82B     |
| 09.44     | Timing duration                              | 0.0–6500.0 min  | 0.0Min  | ◇      | F82C     |
| 09.45     | AI1 input voltage lower limit                | 0.00 V to 09.46   | 3.10V   | ◇      | F82D     |
| 09.46     | AI1 input voltage upper limit                | 09.45 to 10.00 V  | 6.80V   | ◇      | F82E     |
| 09.47     | Module temperature threshold                 | 0– 100°C  | 75°C    | ◇      | F82F     |
| 09.48     | Cooling fan control                          | 0: Fan working during running<br>1: Fan working continuously  | 0       | ◇      | F830     |
| 09.49     | Current running time reached                 | 0.0Min~6500.0Min  | 0.0Min  | ◇      | F831     |

### Group 10 Faults and Protections

| Para. No. | Para. Name                          | Setting Range             | Default | Modify | COM Add. |
|-----------|-------------------------------------|---------------------------|---------|--------|----------|
| 10.00     | Motor overload protection selection | 0: Disabled<br>1: Enabled | 1       | ◇      | F900     |
| 10.01     | Motor overload protection gain      | 0.20~10.00                | 1.00    | ◇      | F901     |
| 10.02     | Motor overload warning coefficient  | 50%~100%                  | 80%     | ◇      | F902     |

| Para. No. | Para. Name   | Setting Range  | Default | Modify | COM Add. |
|-----------|--|--|---------|--------|----------|
| 10.03     | Overvoltage stall gain   | 0~100  | 30      | ◇      | F903     |
| 10.04     | Overvoltage stall protective voltage   | 650V~800V  | 760V    | ◇      | F904     |
| 10.05     | Overcurrent stall gain   | 0~100  | 20      | ◇      | F905     |
| 10.06     | Overcurrent stall protective current   | 100%~200%  | 150%    | ◇      | F906     |
| 10.07     | Short-circuit to ground upon power-on  | 0: Disabled<br>1: Enabled  | 1       | ◇      | F907     |
| 10.08     | Braking unit action starting   | 200.0~2000.0V  | 690.0V  | ◇      | F908     |
| 10.09     | Fault auto reset times   | 0~20   | 0       | ◇      | F909     |
| 10.10     | DO action during fault auto reset  | 0: no action<br>1: Action  | 0       | ◇      | F90A     |
| 10.11     | Time interval of fault auto  | 0.1s~100.0s  | 1.0s    | ◇      | F90B     |
| 10.12     | Input phase loss protection/<br>contactor energizing<br>protection selection | 10: Prohibit<br>11: Allow  | 11      | ◇      | F90C     |
| 10.13     | Output phase loss protection<br>selection                                    | 0: Prohibit<br>1: Allow  | 1       | ◇      | F90D     |
| 10.14     | 1st fault type   | 0: No fault<br>1: Reserved   | E.XXX   | ■      | F90E     |
| 10.15     | 2nd fault type   | 2: Overcurrent during acceleration<br>3: Overcurrent during deceleration<br>4: Overcurrent at constant speed | E.XXX   | ■      | F90F     |

| Para. No. | Para. Name                            | Setting Range   | Default | Modify | COM Add. |
|-----------|---------------------------------------|---|---------|--------|----------|
| 10.16     | 3rd (latest) fault type               | 5: Overvoltage during acceleration<br>6: Overvoltage during deceleration<br>7: Overvoltage at constant speed<br>8: Buffer resistance overload<br>9: Under voltage<br>10: AC drive overload<br>11: Motor overload<br>12: Power input phase loss<br>13: Power output phase loss<br>14: Module overheat<br>15: External equipment fault<br>16: Communication fault<br>17: Contactor fault<br>18: Current detection fault<br>19: Motor auto-tuning fault<br>20: Encoder/PG card fault<br>21: EEPROM read-write fault<br>22: AC drive hardware fault<br>23: Short circuit to ground<br>24: Reserved<br>25: Reserved<br>26: Accumulative running time reached<br>27: User-defined fault 1<br>28: User-defined fault 2<br>29: Accumulative power-on time reached<br>30: Load becoming 0<br>31: PID feedback lost during running<br>40: With-wave current limit fault<br>41: Motor switchover fault during running<br>42: Too large speed deviation<br>43: Motor over-speed<br>45: Motor overheat<br>51: Initial position fault | E.XXX   | ■      | F910     |
| 10.17     | Frequency upon 3rd fault              | —   | Hz      | ■      | F911     |
| 10.18     | Current upon 3rd fault                | —   | A       | ■      | F912     |
| 10.19     | Bus voltage upon 3rd fault            | —   | V       | ■      | F913     |
| 10.20     | DI status upon 3rd fault              | —   | —       | ■      | F914     |
| 10.21     | Output terminal status upon 3rd fault | —   | —       | ■      | F915     |
| 10.22     | AC drive status upon 3rd fault        | —   | —       | ■      | F916     |
| 10.23     | Power-on time upon 3rd fault          | —   | s       | ■      | F917     |
| 10.24     | Running time upon 3rd fault           | —   | s       | ■      | F918     |
| 10.27     | Frequency upon 2nd fault              | —   | Hz      | ■      | F91B     |

| Para. No. | Para. Name                          | Setting Range   | Default | Modify | COM Add. |
|-----------|-------------------------------------|---|---------|--------|----------|
| 10.28     | Current upon 2nd fault              | —   | A       | ■      | F91C     |
| 10.29     | Bus voltage upon 2nd fault          | —   | V       | ■      | F91D     |
| 10.30     | DI status upon 2nd fault            | —   | —       | ■      | F91E     |
| 10.31     | DO status upon 2nd fault            | —   | —       | ■      | F91F     |
| 10.32     | AC drive state upon 2nd fault       | —   | —       | ■      | F920     |
| 10.33     | Power-on time upon 2nd fault        | —   | s       | ■      | F921     |
| 10.34     | Running time upon 2nd fault         | —   | s       | ■      | F922     |
| 10.37     | Frequency upon 1st fault            | —   | Hz      | ■      | F925     |
| 10.38     | Current upon 1st fault              | —   | A       | ■      | F926     |
| 10.39     | Bus voltage upon 1st fault          | —   | V       | ■      | F927     |
| 10.40     | DI state upon 1st fault             | —   | —       | ■      | F928     |
| 10.41     | DO state upon 1st fault             | —   | —       | ■      | F929     |
| 10.42     | AC drive state upon 1st fault       | —   | —       | ■      | F92A     |
| 10.43     | Power-on time upon 1st fault        | —   | s       | ■      | F92B     |
| 10.44     | Running time upon 1st fault         | —   | s       | ■      | F92C     |
| 10.47     | Fault protection action selection 1 | Bit: Motor overload (FU11)<br>0: Free parking<br>1: Stop by stop mode<br>2: continue to run<br>Ten bit: input phase loss (FU12) (reserved)<br>Hundreds bit: output phase loss (FU13)<br>Thousands bit: External Fault (FU15)<br>Ten thousands bit: communication error (FU16)   | 00000   | ◇      | F92F     |
| 10.48     | Fault protection action selection 2 | Bit: keep(FU 20)<br>0: Free parking<br>Ten bit: function code read and write exception (FU21)<br>0: Free parking<br>1: Stop by stop mode<br>Hundreds bit: Inverter overload fault action selection (FU10)<br>0: Free stop<br>1: derating operation<br>Thousands bit: Motor overheating (FU45)<br>Ten thousands bit: Run time arrives (FU26) | 00000   | ◇      | F930     |

| Para. No. | Para. Name   | Setting Range   | Default | Modify | COM Add. |
|-----------|--|---|---------|--------|----------|
| 10.49     | Fault protection action selection 3                  | Bit: User-defined fault 1 (FU27)<br>0: Free parking<br>1: stop according to the stop mode<br>2: keep running<br>Tens bit: User-defined fault 2 (FU28)<br>0: Free parking<br>1: stop according to the stop mode<br>2: keep running<br>Hundreds bit: the power-on time arrives (FU29)<br>0: Free parking<br>1: stop according to the stop mode<br>2: keep running<br>Thousands bit: drop load (FU30)<br>0: Free parking<br>1: Decelerate to stop<br>2: Decelerate to 7% of the rated frequency of the motor and continue to run<br>OK, it will automatically return to the set frequency operation when the load is not dropped.<br>Ten thousand bit: PID feedback lost during runtime (FU31)<br>0: Free parking<br>1: stop according to the stop mode<br>2: keep running | 00000   | ◇      | F931     |
| 10.50     | Fault protection action selection 4                  | Bit: Speed deviation is too large (FU42)<br>0: Free parking<br>1: Stop by stop mode<br>2: continue to run<br>Ten bit: motor over speed (FU43)<br>Hundreds bit: initial position error (FU51)  | 00000   | ◇      | F932     |
| 10.54     | Frequency selection for continuing to run upon fault | 0: Run at the current operating frequency<br>1: run at the set frequency<br>2: Run at the upper limit frequency<br>3: Run at the following frequency limit<br>4: Run at abnormal backup frequency(10.55)  | 0       | ◇      | F936     |
| 10.55     | Backup frequency upon abnormality                    | 0.0%– 100.0% (maximum frequency)  | 100.0%  | ◇      | F937     |
| 10.56     | Type of motor temperature sensor                     | 0: No temperature sensor<br>1: PT100<br>2: PT1000   | 0       | ◇      | F938     |
| 10.57     | Motor overheat protection threshold                  | 0–200°C   | 110°C   | ◇      | F939     |

| Para. No. | Para. Name  | Setting Range  | Default | Modify | COM Add. |
|-----------|---|--|---------|--------|----------|
| 10.58     | Motor overheat warning threshold                            | 0–200°C  | 90°C    | ◇      | F93A     |
| 10.59     | Action selection at instantaneous power failure             | 0: Invalid<br>1: Decelerate<br>2: Decelerate to stop | 0       | ◇      | F93B     |
| 10.60     | Action pause judging voltage at instantaneous power failure | 80.0%– 100.0%  | 100.0%  | ◇      | F93C     |
| 10.61     | Voltage rally judging time at instantaneous power failure   | 0.00– 100.00s  | 0.50s   | ◇      | F93D     |
| 10.62     | Action judging voltage at instantaneous power failure       | 60.0%– 100.0% (standard bus voltage)                 | 80.0%   | ◇      | F93E     |
| 10.63     | Protection upon load becoming 0                             | 0: Disabled<br>1: Enabled                            | 0       | ◇      | F93F     |
| 10.64     | Detection level of load becoming 0                          | 0.0%– 100.0% (rated motor current)                   | 10.0%   | ◇      | F940     |
| 10.65     | Detection time of load becoming 0                           | 0.0–60.0s  | 1.0s    | ◇      | F941     |
| 10.66     | Inverter overheating pre-alarm threshold setting            | 0.0°C~ 150.0°C                                       | 95°C    | ◇      | F942     |
| 10.67     | Over-speed detection value                                  | 0.0%–50.0% (maximum frequency)                       | 20.0%   | ◇      | F943     |
| 10.68     | Over-speed detection time                                   | 0.0–60.0s  | 5.0s    | ◇      | F944     |
| 10.69     | Detection value of too large speed deviation                | 0.0%–50.0% (maximum frequency)                       | 20.0%   | ◇      | F945     |
| 10.70     | Detection time of too large speed deviation                 | 0.0–60.0s  | 0.0s    | ◇      | F946     |

### Group 11 PID functions

| Para. No. | Para. Name          | Setting Range  | Default | Modify | COM Add. |
|-----------|---------------------|--|---------|--------|----------|
| 11.00     | PID setting source  | 0: 11.01 set<br>1: AI1<br>2: AI2<br>3: Reserved<br>4: Pulse setting (DI5)<br>5: Communication setting<br>6: Multi-reference<br>7: keyboard potentiometer | 7       | ◇      | FA00     |
| 11.01     | PID digital setting | 0.0~100.0Bar   | 3.0Bar  | ◇      | FA01     |

| Para. No. | Para. Name   | Setting Range   | Default | Modify | COM Add. |
|-----------|--|---|---------|--------|----------|
| 11.02     | PID feedback source  | 0: AI1<br>1: AI2<br>2: Reserved<br>3: AI1-AI2<br>4: Pulse setting (DI5)<br>5: Communication setting<br>6: AI1 + AI2<br>7: MAX ( AI1 ,  AI2 )<br>8: MIN ( AI1 ,  AI2 ) | 0       | ◇      | FA02     |
| 11.03     | PID action direction   | 0: Forward action<br>1: Reverse action  | 0       | ◇      | FA03     |
| 11.04     | PID setting feedback range                                     | 0-65535   | 10.0Bar | ◇      | FA04     |
| 11.05     | Proportional gain Kp1  | 0.0- 100.0  | 20.0    | ◇      | FA05     |
| 11.06     | Integral time Ti1  | 0.01- 10.00s  | 1.00s   | ◇      | FA06     |
| 11.07     | Differential time Td1  | 0.00- 10.000  | 0.000s  | ◇      | FA07     |
| 11.08     | Cut-off frequency of PID reverse rotation                      | 0.00 to maximum frequency   | 0.00Hz  | ◇      | FA08     |
| 11.09     | PID deviation limit  | 0.0%- 100.0%  | 0.0%    | ◇      | FA09     |
| 11.10     | PID differential limit   | 0.00%- 100.00%  | 0.10%   | ◇      | FA0A     |
| 11.11     | PID setting change time  | 0.00-650.00s  | 0.00s   | ◇      | FA0B     |
| 11.12     | PID feedback filter time                                       | 0.00-60.00s   | 0.00s   | ◇      | FA0C     |
| 11.13     | PID output filter time   | 0.00-60.00s   | 0.00s   | ◇      | FA0D     |
| 11.14     | Reserved   | -   | 0.0%    | ◇      | FA0E     |
| 11.15     | Proportional gain Kp2  | 0.0- 100.0  | 20.0    | ◇      | FA0F     |
| 11.16     | Integral time Ti2  | 0.01- 10.00s  | 1.00s   | ◇      | FA10     |
| 11.17     | Differential time Td2  | 0.000- 10.000s  | 0.000s  | ◇      | FA11     |
| 11.18     | PID parameter switchover condition                             | 0: No switchover<br>1: Switchover via DI<br>2: Automatic switchover based on deviation  | 0       | ◇      | FA12     |
| 11.19     | PID parameter switchover deviation 1                           | 0.0% to 11.20   | 20.0%   | ◇      | FA13     |
| 11.20     | PID parameter switchover deviation 2                           | 11.19 to 100.0%   | 80.0%   | ◇      | FA14     |
| 11.21     | PID initial value  | 0.0%- 100.0%  | 0.0%    | ◇      | FA15     |
| 11.22     | PID initial value holding time                                 | 0.00-650.00s  | 0.00s   | ◇      | FA16     |
| 11.23     | Maximum deviation between two PID outputs in forward direction | 0.00%- 100.00%  | 1.00%   | ◇      | FA17     |

| Para. No. | Para. Name   | Setting Range  | Default | Modify | COM Add. |
|-----------|--|--|---------|--------|----------|
| 11.24     | Maximum deviation between two PID outputs in REVERSE direction | 0.00%~100.00%  | 1.00%   | ◇      | FA18     |
| 11.25     | PID integral property  | Bit: integral separation<br>0: invalid<br>1: valid<br>Ten Bit: Whether to stop the integration after outputting to the limit<br>0: Continue to score<br>1: stop the points | 00      | ◇      | FA19     |
| 11.26     | Detection level of PID feedback loss                           | 0.0%: No detection<br>0.1% to 100.0%   | 0.0%    | ◇      | FA1A     |
| 11.27     | Detection time of PID feedback loss                            | 0.0s to 20.0s  | 0.0s    | ◇      | FA1B     |
| 11.28     | Selection of PID operation at stop                             | 0: Operation at stopped<br>1: Operation at stop  | 0       | ◇      | FA1C     |

### Group 12 Swing Frequency, Fixed Length and Count

| Para. No. | Para. Name                              | Setting Range  | Default | Modify | COM Add. |
|-----------|---|--|---------|--------|----------|
| 12.00     | Swing frequency setting mode            | 0: Relative to the central frequency<br>1: Relative to the maximum frequency | 0       | ◇      | FB00     |
| 12.01     | Swing frequency amplitude               | 0.0%~100.0%  | 0.0%    | ◇      | FB01     |
| 12.02     | Jump frequency amplitude                | 0.0%~50.0%   | 0.0%    | ◇      | FB02     |
| 12.03     | Swing frequency cycle                   | 0.1s~3000.0s   | 10.0s   | ◇      | FB03     |
| 12.04     | Triangular wave rising time coefficient | 0.1%~100.0%  | 50.0%   | ◇      | FB04     |
| 12.05     | Set length                              | 0m~65535m  | 1000m   | ◇      | FB05     |
| 12.06     | Actual length                           | 0m~65535m  | 0m      | ◇      | FB06     |
| 12.07     | Number of pulses per meter              | 0.1~6553.5   | 100.0   | ◇      | FB07     |
| 12.08     | Set count value                         | 1~65535  | 1000    | ◇      | FB08     |
| 12.09     | Designated count value                  | 1~65535  | 1000    | ◇      | FB09     |

### Group 13 Multi-Reference and Simple PLC Function

| Para. No. | Para. Name  | Setting Range  | Default | Modify | COM Add. |
|-----------|-------------|----------------|---------|--------|----------|
| 13.00     | Reference 0 | -100.0%~100.0% | 0.0%    | ◇      | FC00     |
| 13.01     | Reference 1 | -100.0%~100.0% | 0.0%    | ◇      | FC01     |
| 13.02     | Reference 2 | -100.0%~100.0% | 0.0%    | ◇      | FC02     |
| 13.03     | Reference 3 | -100.0%~100.0% | 0.0%    | ◇      | FC03     |
| 13.04     | Reference 4 | -100.0%~100.0% | 0.0%    | ◇      | FC04     |
| 13.05     | Reference 5 | -100.0%~100.0% | 0.0%    | ◇      | FC05     |
| 13.06     | Reference 6 | -100.0%~100.0% | 0.0%    | ◇      | FC06     |



| Para. No. | Para. Name   | Setting Range  | Default | Modify | COM Add. |
|-----------|--|--|---------|--------|----------|
| 13.07     | Reference 7  | -100.0% ~ 100.0%   | 0.0%    | ◇      | FC07     |
| 13.08     | Reference 8  | -100.0% ~ 100.0%   | 0.0%    | ◇      | FC08     |
| 13.09     | Reference 9  | -100.0% ~ 100.0%   | 0.0%    | ◇      | FC09     |
| 13.10     | Reference 10   | -100.0% ~ 100.0%   | 0.0%    | ◇      | FC0A     |
| 13.11     | Reference 11   | -100.0% ~ 100.0%   | 0.0%    | ◇      | FC0B     |
| 13.12     | Reference 12   | -100.0% ~ 100.0%   | 0.0%    | ◇      | FC0C     |
| 13.13     | Reference 13   | -100.0% ~ 100.0%   | 0.0%    | ◇      | FC0D     |
| 13.14     | Reference 14   | -100.0% ~ 100.0%   | 0.0%    | ◇      | FC0E     |
| 13.15     | Reference 15   | -100.0% ~ 100.0%   | 0.0%    | ◇      | FC0F     |
| 13.16     | Simple PLC running mode                                  | 0: Stop after the AC drive runs one cycle<br>1: Keep final values after the AC drive runs one cycle<br>2: Repeat after the AC drive runs one cycle   | 0       | ◇      | FC10     |
| 13.17     | Simple PLC retentive selection                           | Bit: Memory selection when power off<br>0: No memory when power off<br>1: Memory when power off<br>Tens bit: memory selection during stop<br>0: No memory when stopped<br>1: Memory when stopped | 00      | ◇      | FC11     |
| 13.18     | Running time of simple PLC reference 0                   | 0.0s (h) ~6500.0 (h)   | 0.0s(h) | ◇      | FC12     |
| 13.19     | Acceleration/deceleration time of simple PLC reference 0 | 0~3  | 0       | ◇      | FC13     |
| 13.20     | Running time of simple PLC reference 1                   | 0.0s (h) ~6500.0 (h)   | 0.0s(h) | ◇      | FC14     |
| 13.21     | Acceleration/deceleration time of simple PLC reference 1 | 0~3  | 0       | ◇      | FC15     |
| 13.22     | Running time of simple PLC reference 2                   | 0.0s (h) ~6500.0 (h)   | 0.0s(h) | ◇      | FC16     |
| 13.23     | Acceleration/deceleration time of simple PLC reference 2 | 0~3  | 0       | ◇      | FC17     |
| 13.24     | Running time of simple PLC reference 3                   | 0.0s (h) ~6500.0 (h)   | 0.0s(h) | ◇      | FC18     |
| 13.25     | Acceleration/deceleration time of simple PLC reference 3 | 0~3  | 0       | ◇      | FC19     |
| 13.26     | Running time of simple PLC reference 4                   | 0.0s (h) ~6500.0 (h)   | 0.0s(h) | ◇      | FC1A     |
| 13.27     | Acceleration/deceleration time of simple PLC reference 4 | 0~3  | 0       | ◇      | FC1B     |
| 13.28     | Running time of simple PLC reference 5                   | 0.0s (h) ~6500.0 (h)   | 0.0s(h) | ◇      | FC1C     |
| 13.29     | Acceleration/deceleration time of simple PLC reference 5 | 0~3  | 0       | ◇      | FC1D     |
| 13.30     | Running time of simple PLC reference 6                   | 0.0s (h) ~6500.0 (h)   | 0.0s(h) | ◇      | FC1E     |

| Para. No. | Para. Name  | Setting Range   | Default | Modify | COM Add. |
|-----------|---|---|---------|--------|----------|
| 13.31     | Acceleration/deceleration time of simple PLC reference 6  | 0~3   | 0       | ◇      | FC1F     |
| 13.32     | Running time of simple PLC reference 7                    | 0.0s (h) ~6500.0 (h)  | 0.0s(h) | ◇      | FC20     |
| 13.33     | Acceleration/deceleration time of simple PLC reference 7  | 0~3   | 0       | ◇      | FC21     |
| 13.34     | Running time of simple PLC reference 8                    | 0.0s (h) ~6500.0 (h)  | 0.0s(h) | ◇      | FC22     |
| 13.35     | Acceleration/deceleration time of simple PLC reference 8  | 0~3   | 0       | ◇      | FC23     |
| 13.36     | Running time of simple PLC reference 9                    | 0.0s (h) ~6500.0 (h)  | 0.0s(h) | ◇      | FC24     |
| 13.37     | Acceleration/deceleration time of simple PLC reference 9  | 0~3   | 0       | ◇      | FC25     |
| 13.38     | Running time of simple PLC reference 10                   | 0.0s (h) ~6500.0 (h)  | 0.0s(h) | ◇      | FC26     |
| 13.39     | Acceleration/deceleration time of simple PLC reference 10 | 0~3   | 0       | ◇      | FC27     |
| 13.40     | Running time of simple PLC reference 11                   | 0.0s (h) ~6500.0 (h)  | 0.0s(h) | ◇      | FC28     |
| 13.41     | Acceleration/deceleration time of simple PLC reference 11 | 0~3   | 0       | ◇      | FC29     |
| 13.42     | Running time of simple PLC reference 12                   | 0.0s (h) ~6500.0 (h)  | 0.0s(h) | ◇      | FC2A     |
| 13.43     | Acceleration/deceleration time of simple PLC reference 12 | 0~3   | 0       | ◇      | FC2B     |
| 13.44     | Running time of simple PLC reference 13                   | 0.0s (h) ~6500.0 (h)  | 0.0s(h) | ◇      | FC2C     |
| 13.45     | Acceleration/deceleration time of simple PLC reference 13 | 0~3   | 0       | ◇      | FC2D     |
| 13.46     | Running time of simple PLC reference 14                   | 0.0s (h) ~6500.0 (h)  | 0.0s(h) | ◇      | FC2E     |
| 13.47     | Acceleration/deceleration time of simple PLC reference 14 | 0~3   | 0       | ◇      | FC2F     |
| 13.48     | Running time of simple PLC reference 15                   | 0.0s (h) ~6500.0 (h)  | 0.0s(h) | ◇      | FC30     |
| 13.49     | Acceleration/deceleration time of simple PLC reference 15 | 0~3   | 0       | ◇      | FC31     |
| 13.50     | Time unit of simple PLC running                           | 0: s (second)<br>1:h (hour)   | 0       | ◇      | FC32     |
| 13.51     | Reference 0 source  | 0: Set by 13.00<br>1: AI1<br>2: AI2<br>3: AI3 keyboard potentiometer<br>4: Pulse setting<br>5: PID<br>6: Set by preset frequency (01. 08), modified via terminal UP/ DOWN | 7       | ◇      | FC33     |

## Group 14 Communication Parameters

| Para. No. | Para. Name                               | Setting Range   | Default | Modify | COM Add. |
|-----------|--|---|---------|--------|----------|
| 14.00     | Baud rate                                | Bit: MODBUS<br>0: 300BPS<br>1: 600BPS<br>2: 1200BPS<br>3: 2400BPS<br>4: 4800BPS<br>5: 9600BPS<br>6: 19200BPS<br>7: 38400BPS<br>8: 57600BPS<br>Ten bit: Profibus-DP<br>0: 115200BPS<br>1: 208300BPS<br>2: 256000BPS<br>3: 512000Bps<br>Hundred's bit:Reserved<br>Thousand's bit (CANlink baud rate)<br>0: 20<br>1: 50<br>2: 100<br>3: 125<br>4: 250<br>5: 500<br>6: 1M | 6005    | ◇      | FD00     |
| 14.01     | MODBUS data format                       | 0: No parity (8-N-2)<br>1: Even check (8-E-1)<br>2: Odd parity (8-O-1)<br>3: No parity (8-N-1)  | 0       | ◇      | FD01     |
| 14.02     | Local address                            | 0: Broadcast address;<br>1 to 247   | 1       | ◇      | FD02     |
| 14.03     | MODBUS response delay                    | 0ms~20ms  | 2       | ◇      | FD03     |
| 14.04     | Communication timeout                    | 0.0: invalid<br>0.1s to 60.0s   | 0.0     | ◇      | FD04     |
| 14.05     | Modbus protocol selection                | Bit: MODBUS<br>0: non-standard MODBUS protocol<br>1: Standard MODBUS protocol<br>Ten bit:Reserved   | 31      | ◇      | FD05     |
| 14.06     | Current resolution read by communication | 0: 0.01<br>1: 0.1   | 0       | ◇      | FD06     |
| 14.07     | Communication master-slave mode          | 0: Slave<br>1: Mater  | 0       | ◇      | FD07     |

## Group 15~16 Reserved

## Group 17 Function Code Management

| Para. No. | Para. Name    | Setting Range | Default | Modify | COM Add. |
|-----------|---------------|---------------|---------|--------|----------|
| 17.00     | User password | 0~65535       | 0       | ◇      | 1F00     |

| Para. No. | Para. Name                                    | Setting Range  | Default | Modify | COM Add. |
|-----------|---|--|---------|--------|----------|
| 17.01     | Parameter initialization                      | 0: No operation<br>1: Restore factory parameters except motor parameters<br>2: Clear records<br>4: Back up current user parameters<br>501: Restore user backup parameters        | 0       | ◇      | 1F01     |
| 17.02     | Parameter display property                    | Bit: 00 group display selection<br>0: Not displayed<br>1: Display<br>Ten: Group(18~30) display the selection<br>0: Not displayed<br>1: Display                                   | 11      | ◇      | 1F02     |
| 17.03     | Selection of individualized parameter display | Bit: User custom parameter group display selection<br>0: Not displayed<br>1: Display<br>Ten bit: User Change Parameter Group Display Selection<br>0: Not displayed<br>1: Display | 00      | ◇      | 1F03     |
| 17.04     | Selection of parameter modification           | 0: Can be modified<br>1: Cannot be modified  | 0       | ◇      | 1F04     |

### Group18~22 Reserved

### Group 23 Control Optimization Parameters

| Para. No. | Para. Name                            | Setting Range  | Default | Modify | COM Add. |
|-----------|---------------------------------------|--|---------|--------|----------|
| 23.00     | DPWM switchover frequency upper limit | 0.00– 15.00 Hz   | 8.00Hz  | ◇      | A500     |
| 23.01     | PWM modulation mode                   | 0: Asynchronous modulation<br>1: Synchronous modulation                | 0       | ◇      | A501     |
| 23.02     | Dead zone compensation mode selection | 0: No compensation<br>1: Compensation mode 1<br>2: Compensation mode 2 | 1       | ◇      | A502     |
| 23.03     | Random PWM depth                      | 0: Random PWM invalid<br>1-10  | 0       | ◇      | A503     |
| 23.04     | Rapid current limit                   | 0: Disabled<br>1: Enabled  | 1       | ◇      | A504     |
| 23.05     | Current detection compensation        | 0- 100   | 5       | ◇      | A505     |
| 23.06     | Under voltage threshold               | 60.0%– 140.0%  | 100%    | ◇      | A506     |
| 23.07     | SVC optimization mode selection       | 0: No optimization<br>1: Optimization mode 1<br>2: Optimization mode 2 | 2       | ◇      | A507     |
| 23.08     | Dead-zone time adjustment             | 100%–200%  | 150%    | ◇      | A508     |
| 23.09     | Overvoltage threshold                 | 200.0–2500.0 V   | 800.0V  | ◇      | A509     |

| Para. No. | Para. Name                              | Setting Range | Default | Modify | COM Add. |
|-----------|---|---------------|---------|--------|----------|
| 23.10     | Low frequency variable carrier enable   | 0-1           | 1       | ◇      | A509     |
| 23.11     | Zero speed running output enable        | 0-1           | 1       | ◇      | A510     |
| 23.12     | Power phase loss protection sensitivity | 0-30.0%       | 13%     | ◇      | A511     |

# Chapter 6: Parameter Description

## Group 00 Monitoring parameter group

The 00 parameter group is used to monitor the operating status information of the inverter. The customer can view it through the panel to facilitate on-site debugging, and can also read the parameter group value through communication for monitoring by the host computer.

The communication address is 0x7000~0x7044.

Among them, 00.00~00.31 are the running and stop monitoring parameters defined in 08.03 and 08.04.

|           |                          |                  |                        |
|-----------|--------------------------|------------------|------------------------|
| 00.0<br>0 | Running<br>frequency(Hz) | Display<br>range | 0.00~500.00Hz(01.22=2) |
| 00.0<br>1 | Setting<br>frequency(Hz) |                  | 0.00~500.00Hz(01.22=1) |

Displays the theoretical running frequency of the inverter and the absolute value of the set frequency.

For the actual output frequency of the inverter, see 00.19

|       |                   |               |              |
|-------|-------------------|---------------|--------------|
| 00.02 | DC bus voltage(V) | Display range | 0.0V~3000.0V |
|-------|-------------------|---------------|--------------|

Display the inverter bus voltage value

|       |                       |               |          |
|-------|-----------------------|---------------|----------|
| 00.03 | The output voltage(V) | Display range | 0V~1140V |
|-------|-----------------------|---------------|----------|

Display the output voltage value of the inverter during operation

|       |                       |               |   |
|-------|-----------------------|---------------|---|
| 00.04 | The output current(V) | Display range | 0.00A~655.35A (≤55KW)<br>0.0A~6553.5A (>55KW) |
|-------|-----------------------|---------------|---|

Display the output current value of the inverter during operation

|       |                      |               |         |
|-------|----------------------|---------------|---------|
| 00.05 | The output power(kW) | Display range | 0~32767 |
|-------|----------------------|---------------|---------|

The calculated value of actual output power of motor

|       |                  |               |                  |
|-------|------------------|---------------|------------------|
| 00.06 | Output torque(%) | Display range | -200.0% ~ 200.0% |
|-------|------------------|---------------|------------------|

Display the output torque value of the inverter during operation

|       |                 |               |          |
|-------|-----------------|---------------|----------|
| 00.07 | DI input status | Display range | 0~ 32767 |
|-------|-----------------|---------------|----------|

Displays the current X terminal input state value in hexadecimal. After conversion into binary data, each bit corresponds to the X input signal, 1 indicates that the input is a high-level signal, and 0 indicates that the input is a low-level signal. The corresponding relationship between each bit and the input terminal is as follows:

| Bit0 | Bit1 | Bit2 | Bit3 |
|------|------|------|------|
| DI1  | DI2  | DI3  | DI4  |
| Bit4 | Bit5 | Bit6 | Bit7 |
| DI5  | -    | -    | -    |

|       |                  |               |        |
|-------|------------------|---------------|--------|
| 00.08 | DO output status | Display range | 0~1023 |
|-------|------------------|---------------|--------|

Displays the current DO terminal output status value in hexadecimal. After conversion into binary data, each bit corresponds to a DO signal, 1 means the output is high, and 0 means the output is low. The correspondence between each bit and DO is as follows:

| Bit0 | Bit1    | Bit2 | Bit3 |
|------|---------|------|------|
| -    | Relay 1 | -    | HDO  |

|       |                            |               |                                |
|-------|----------------------------|---------------|--------------------------------|
| 00.10 | A11 voltage) /current (mA) | Display range | 0.00V~10.57V<br>0.00mA~20.00mA |
|-------|----------------------------|---------------|--------------------------------|

When 05.40 is set to 0, the A11 sampling data display unit is voltage (V)

When 05.40 is set to 1, A11 sampling data display unit is current (mA)

|       |                    |               |         |
|-------|--------------------|---------------|---------|
| 00.14 | Load speed display | Display range | 0~65535 |
|-------|--------------------|---------------|---------|

See 08.12 for details.

|       |              |               |         |
|-------|--------------|---------------|---------|
| 00.15 | PID set      | Display range | 0~65535 |
| 00.16 | PID feedback | Display range | 0~65535 |

Display PID set value and feedback value, the value format is as follows:

PID setting=PID setting (percent)\*11.04

PID feedback=PID feedback (percent)\*11.04

|       |                                  |               |                   |
|-------|----------------------------------|---------------|-------------------|
| 00.18 | PULSE pulse input frequency(kHz) | Display range | 0.00kHz~100.00KHz |
|-------|----------------------------------|---------------|-------------------|

Display DI5 high-speed pulse sampling frequency, the minimum unit is 0.01KHz

|       |                |               |  |
|-------|----------------|---------------|--|
| 00.19 | Feedback speed | Display range | -320.00Hz~320.00Hz<br>-500.0Hz~500.0Hz |
|-------|----------------|---------------|--|

Display the actual output frequency of the inverter

The ten-digit setting value of function code 08.12 (load speed display decimal point) indicates the number of decimal points in 00.19/00.29,

When it is set to 2, the number of decimal points in 00.19 is 2, and the Display range is -320.00Hz~320.00Hz;

When it is set to 1, the number of decimal points in 00.19 is 1, and the Display range is -500.0Hz to 500.0Hz.

|       |                        |               |               |
|-------|------------------------|---------------|---------------|
| 00.20 | Surplus remaining time | Display range | 0.0~6500.0min |
|-------|------------------------|---------------|---------------|

Displays the remaining run time of the timing run

For the introduction of timing operation, see the introduction of parameters 09.42~09.44

|       |                                       |               |                                    |
|-------|---------------------------------------|---------------|------------------------------------|
| 00.21 | AI1 voltage before correction         | Display range | 0.000V~10.570V                     |
| 00.22 | AI2 voltage/Current before correction | Display range | 0.000V~10.570V<br>0.000mA~20.000mA |

Displays the actual value of the analog input sampled voltage/current.

The actual voltage/current used is linearly corrected to make the deviation between the sampled voltage/current and the actual input voltage/current smaller.

See 00.09, 00.10, 00.11 for the actual correction voltage/current used.

|       |                 |               |               |
|-------|-----------------|---------------|---------------|
| 00.24 | Linear velocity | Display range | 0~65535 m/min |
|-------|-----------------|---------------|---------------|

Displays the linear velocity of the DI5 high-speed pulse sampling, in m/min

Calculate the linear velocity value according to the actual number of sampled pulses per minute and 12.07 (pulses per meter)

|       |                       |               |           |
|-------|-----------------------|---------------|-----------|
| 00.27 | PULSE input frequency | Display range | 0~65535Hz |
|-------|-----------------------|---------------|-----------|

Display the DI5 high-speed pulse sampling frequency, the unit is 1Hz. It is the same data as 00.18, only the displayed unit is different

|       |                         |               |                  |
|-------|-------------------------|---------------|------------------|
| 00.28 | Communication set value | Display range | -100.00%~100.00% |
|-------|-------------------------|---------------|------------------|

Display data written through communication address 0x1000

|       |                          |               |                                   |
|-------|--------------------------|---------------|-----------------------------------|
| 00.30 | Main frequency X display | Display range | 0.00Hz~320.00Hz<br>0.0Hz~3200.0Hz |
|-------|--------------------------|---------------|-----------------------------------|

Main frequency source set frequency

|       |                               |               |                                   |
|-------|-------------------------------|---------------|-----------------------------------|
| 00.31 | Auxiliary frequency Y display | Display range | 0.00Hz~320.00Hz<br>0.0Hz~3200.0Hz |
|-------|-------------------------------|---------------|-----------------------------------|

Auxiliary frequency source set frequency

|       |                  |               |                  |
|-------|------------------|---------------|------------------|
| 00.35 | Target torque(%) | Display range | -200.0% ~ 200.0% |
|-------|------------------|---------------|------------------|

Display the current torque upper limit set value

|       |                              |               |                        |
|-------|------------------------------|---------------|------------------------|
| 00.39 | VF separation target voltage | Display range | 0V~Motor rated voltage |
| 00.40 | VF separation output voltage | Display range | 0V~Motor rated voltage |

Displays the target output voltage and the current actual output voltage when operating in the VF separation state

For the VF separation mode, please refer to the related introduction of the 04 group.

|       |                         |               |   |
|-------|-------------------------|---------------|---|
| 00.41 | DI input status display | Display range | - |
|-------|-------------------------|---------------|---|

Visually display the DI terminal status, the display format is as follows:

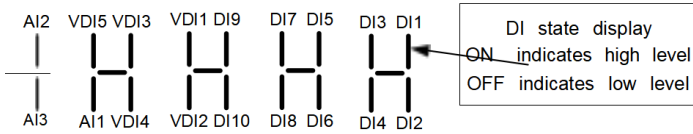

|       |                          |               |   |
|-------|--------------------------|---------------|---|
| 00.42 | DO output status display | Display range | - |
|-------|--------------------------|---------------|---|

Visually display the DO terminal status, the display format is as follows:

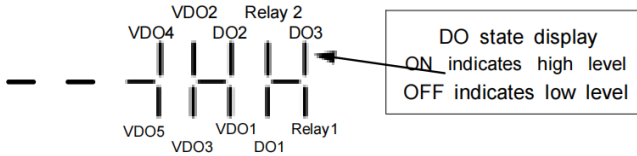

|       |                             |               |   |
|-------|-----------------------------|---------------|---|
| 00.43 | DI function status display1 | Display range | - |
|-------|-----------------------------|---------------|---|

Visually display whether terminal functions 1 to 40 are valid

There are 5 digital tubes on the keyboard, and each digital tube display can represent 8 function options

The definition of digital tube is as follows:

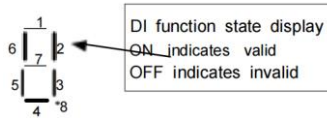

The digital tubes represent functions from right to left:

1~8、9~16、17~24、25~32、33~40

|       |                             |               |   |
|-------|-----------------------------|---------------|---|
| 00.44 | DI function status display2 | Display range | - |
|-------|-----------------------------|---------------|---|

Visually display whether terminal functions 41 to 59 are valid

The display is similar to 00.43

The digital tubes represent functions 41-48, 49-56, 57-59 from right to left respectively

|       |                  |               |           |
|-------|------------------|---------------|-----------|
| 00.58 | Z signal counter | Display range | 0 ~ 65535 |
|-------|------------------|---------------|-----------|

Display current ABZ or UVW encoder Z-phase pulse count

When the encoder rotates forward or reverse every time, the corresponding value is added or subtracted by 1.

Check the value to check whether the encoder is installed normally.

|       |               |               |                    |
|-------|---------------|---------------|--------------------|
| 00.59 | Set frequency | Display range | -100.00% ~ 100.00% |
|-------|---------------|---------------|--------------------|

|       |                   |               |                    |
|-------|-------------------|---------------|--------------------|
| 00.60 | running frequency | Display range | -100.00% ~ 100.00% |
|-------|-------------------|---------------|--------------------|

Display the current set frequency and running frequency, 100.00% corresponds to the maximum frequency of the inverter (01.10)

|       |                         |               |           |
|-------|-------------------------|---------------|-----------|
| 00.61 | Inverter running status | Display range | 0 ~ 65535 |
|-------|-------------------------|---------------|-----------|

Display inverter running status information, the data definition format is as follows:

|       |      |  |
|-------|------|--|
| 00.61 | Bit0 | 0 : STOP ; 1 : FWD ; 2 : REV                   |
|       | Bit1 |  |
|       | Bit2 | 0 : Constant ; 1 : Accelerate ; 2 : Decelerate |
|       | Bit3 |  |
|       | Bit4 | 0 : DC Bus normal ; 1 : Under-voltage          |

|       |                    |               |        |
|-------|--------------------|---------------|--------|
| 00.62 | Current fault code | Display range | 0 ~ 99 |
|-------|--------------------|---------------|--------|



## Group 01 Basic Function Group

|       |                 |   |   |                 |
|-------|-----------------|---|---|-----------------|
| 01.00 | GP type display |   | Default   | Model dependent |
|       | Setting Range   | 1 | G type (constant torque load)                   |                 |
|       |                 | 2 | P type (variable torque load e.g. fan and pump) |                 |

This parameter is used to display the delivered model and cannot be modified

1: Applicable to constant torque load with rated parameters specified

2: Applicable to variable torque load (fan and pump) with rated parameters specified

|       |                 |   |                                       |   |
|-------|-----------------|---|---------------------------------------|---|
| 01.01 | Motor 1 control |   | Default                               | 0 |
|       | Setting Range   | 0 | Sensor less flux vector control (SVC) |   |
|       |                 | 1 | Reserved                              |   |
|       |                 | 2 | Voltage/Frequency (V/F) control       |   |

0: Sensor less flux vector control (SVC)

It indicates open-loop vector control, and is applicable to high-performance control applications such as machine tool, centrifuge, wire drawing machine and injection molding machine. One AC drive can operate only one motor.

1: Reserved

2: Voltage/Frequency (V/F) control

It is applicable to applications with low load requirements or applications where one AC drive operates multiple motors, such as fan and pump.

Note: If vector control is used, motor auto-tuning must be performed because the advantages of vector control can only be utilized after correct motor parameters are obtained. Better performance can be achieved by adjusting speed regulator parameters in group 02 (or groups A2, A3, and A4 respectively for motor 2, 3, and 4).

|       |                          |   |                                      |   |
|-------|--------------------------|---|--------------------------------------|---|
| 01.02 | Command source selection |   | Default                              | 0 |
|       | Setting Range            | 0 | Operation panel control (LED off)    |   |
|       |                          | 1 | Terminal control (LED on)            |   |
|       |                          | 2 | Communication control (LED blinking) |   |

It is used to determine the input channel of the AC drive control commands, such as run, stop, forward rotation, reverse rotation and jog operation.

0: Operation panel control channel (“LOCAL/REMOT” indicator off)

Commands are given by pressing keys “RUN” and “STOP/RES” on the operation panel

1: Terminal control (“LOCAL/REMOT” indicator on)

Commands are given by means of multifunctional input terminals with functions such as FWD, REV, JOGF, and JOGR.

2: Communication control channel (“LOCAL/REMOT” indicator blinking)

Commands are given from host computer.

|       |                                   |   |  |   |
|-------|-----------------------------------|---|--|---|
| 01.03 | Main frequency source X selection |   | Default  | 0 |
|       | Setting Range                     | 0 | Digital setting (Preset frequency 01.08, UP/DOWN adjustable, non-retentive at power failure) |   |
|       |                                   | 1 | Digital setting (Preset frequency 01.08, UP/DOWN adjustable, retentive at power failure)     |   |
|       |                                   | 2 | AI1  |   |
|       |                                   | 3 | AI2  |   |
|       |                                   | 4 | AI3 (keyboard potentiometer)   |   |

|  |   |                       |
|--|---|-----------------------|
|  | 5 | Pulse setting (DI5)   |
|  | 6 | Multi-reference       |
|  | 7 | PLC                   |
|  | 8 | PID                   |
|  | 9 | Communication setting |

It is used to select the setting channel of the main frequency. You can set the main frequency in the following 10 channels:

0: Digital setting (non-retentive at power failure)

The initial value of the set frequency is the value of 01.08 (Preset frequency). You can change the set frequency by pressing ▲ and ▼ on the operation panel (or using the UP/DOWN functions of input terminals).

When the AC drive is powered on again after power failure, the set frequency reverts to the value of 01.08.

1: Digital setting (retentive at power failure)

The initial value of the set frequency is the value of 01.08 (Preset frequency). You can change the set frequency by pressing keys ▲ and ▼ on the operation panel (or using the UP/DOWN functions of input terminals).

When the AC drive is powered on again after power failure, the set frequency is the value memorized at the moment of the last power failure.

Note that 01.23 (Retentive of digital setting frequency upon power failure) determines whether the set frequency is memorized or cleared when the AC drive stops. It is related to stop rather than power failure.

2: AI1

3: AI2

4: AI3 (keyboard potentiometer)

5: Pulse setting (DI5)

The frequency is set by DI5 (high-speed pulse). The signal specification of pulse setting is 9–30 V (voltage range) and 0–100 kHz (frequency range). Input pulse can only be given from multifunctional input terminals DI5. The relation between DI5 terminal input pulse frequency and the corresponding set, is designed through the 05.28~05.31, the corresponding relation of two points is straight line corresponding relation. The corresponding value 100% of pulse setting corresponds to the value of 01.10 (Maximum frequency).

6: Multi-reference

In multi-reference mode, combinations of different DI terminal states correspond to different set frequencies. The DSI-100 supports a maximum of 16 speeds implemented by 16 state combinations of four DI terminals (allocated with functions 12 to 15) in Group PC. The multiple references indicate percentages of the value of 01.10 (Maximum frequency).

If a DI terminal is used for the multi-reference function, you need to perform related setting in group 04.

7. Simple PLC

When the frequency source is a simple PLC, the operating frequency source of the inverter can be switched between 1 to 16 arbitrary frequency commands. The holding time and the respective acceleration and deceleration time of the 1 to 16 frequency commands can also be set by the user. For details, please refer to Instructions for PC groups.

8. PID

Select the output of the process PID control as the operating frequency. Generally used for on-site process closed-loop control, such as constant pressure closed-loop control, constant tension closed-loop control and other occasions.

When using PID as the frequency source, it is necessary to set the relevant parameters of the "PID function" of the PA group.

9. Communication given

Refers to the frequency given by the communication method.

|       |                            |   |   |   |
|-------|----------------------------|---|---|---|
| 01.04 | Auxiliary frequency source |   | Default   | 0 |
|       | Setting Range              | 0 | Digital setting ( Preset frequency 01.08, UP/DOWN adjustable, non-retentive at power failure) |   |
|       |                            | 1 | Digital setting (Preset frequency 01.08, UP/DOWN adjustable, retentive at power failure)      |   |
|       |                            | 2 | AI1   |   |
|       |                            | 3 | AI2   |   |
|       |                            | 4 | AI3 (keyboard potentiometer)  |   |
|       |                            | 5 | Pulse setting (DI5)   |   |
|       |                            | 6 | Multi-reference   |   |
|       |                            | 7 | PLC   |   |
|       |                            | 8 | PID   |   |
| 9     | Communication setting      |   |   |   |

When the auxiliary frequency source is used as an independent frequency reference channel (that is, the frequency source is selected as X to Y switching), its usage is the same as that of the main frequency source X. For the usage method, please refer to the relevant instructions in 01.03.

When the auxiliary frequency source is used as the superposition reference (that is, the composite realization frequency reference of the main frequency source X and the auxiliary frequency source Y), it is necessary to pay attention to:

1. When the auxiliary frequency source is a digital reference, the preset frequency (01.08) does not work. The frequency adjustment by the user through the ▲ and ▼ keys of the keyboard (or the UP and DOWN of the multi-function input terminal) is directly in the main reference. adjusted on a frequency basis.

2. When the auxiliary frequency source is given by analog input (AI1, AI2) or pulse input, 100% of the input setting corresponds to the range of auxiliary frequency source, which can be set by 01.05 and 01.06.

3. When the frequency source is pulse input given, it is similar to analog given.

Tip: The auxiliary frequency source Y selection and the main frequency source X selection cannot be set to the same channel, that is, 01.03 and 01.04 should not be set to the same value, otherwise it will easily cause confusion.

|       |  |                              |                               |   |
|-------|--|------------------------------|-------------------------------|---|
| 01.05 | Range of auxiliary frequency Y for X and Y |                              | Default                       | 0 |
|       | Setting Range                              | 0                            | Relative to maximum frequency |   |
| 1     |  | Relative to main frequency X |                               |   |
| 01.06 | Range of auxiliary frequency Y for X and Y |                              | Default                       | 0 |
|       | Setting Range                              |                              | 0% ~ 150%                     |   |

When the frequency source is selected as "frequency superposition" (ie 08 is set to 1, 3 or 4), these two parameters are used to determine the adjustment range of the auxiliary frequency source.

01.05 is used to determine the object corresponding to the auxiliary frequency source range. It can be selected relative to the maximum frequency or relative to the main frequency source X. If it is selected to be relative to the main frequency source, the range of the auxiliary frequency source will follow the main frequency X. changes with the

|       |                            |              |   |   |
|-------|----------------------------|--------------|---|---|
| 01.07 | Frequency source selection |              | Default   | 0 |
|       | Setting Range              | Unit's digit | Frequency source selection  |   |
|       |                            | 0            | Main frequency source X   |   |
|       |                            | 1            | X and Y operation<br>(operation relationship determined by ten's digit) |   |
|       |                            | 2            | Switchover between X and Y  |   |
|       |                            | 3            | Switchover between X and "X and Y operation"                            |   |
|       |                            | 4            | Switchover between Y and "X and Y operation"                            |   |
|       |                            | Ten's digit  | X and Y operation relationship  |   |
|       |                            | 0            | X + Y   |   |
|       |                            | 1            | X – Y   |   |
|       |                            | 2            | Maximum   |   |
| 3     | Minimum                    |              |   |   |

It is used to select the frequency setting channel. If the frequency source involves X and Y operation, you can set the frequency offset in 01.21 for superposition to the X and Y operation result, flexibly satisfying various requirements.

Unit's digit: Frequency source selection

0: Main frequency source X

Main frequency source X as target frequency

1: X and Y operation

Main and auxiliary operation result as the target frequency, main and auxiliary operation relationship see the description of ten digits.

2: Main frequency source X and auxiliary frequency Y switchover

When the multi-function input terminals function 18 (frequency switch) is invalid, the main frequency X as the target frequency.

When the multi-function input terminals function 18 (frequency switch) is valid, the auxiliary frequency Y as the target frequency.

3: The main frequency source X switchover with the main and auxiliary operation result.

When the multi-function input terminals function 18 (frequency switch) is invalid, the main frequency X as the target frequency.

When the multi-function input terminals function 18 (frequency switch) is valid, the main and auxiliary operation result as the target frequency.

4: The auxiliary frequency source Y switchover with the main and auxiliary operation result.

When the multi-function input terminals function 18 (frequency switch) is invalid, the auxiliary frequency Y as the target frequency.

When the multi-function input terminals function 18 (frequency switch) is valid, the main and auxiliary operation result as the target frequency.

Ten digits: Frequency source main and auxiliary operation relations.

0: X+Y

The target frequency is the sum of main frequency X and auxiliary frequency Y.

1: X-Y

The target frequency is the difference between main frequency X and auxiliary frequency Y.

2: MAX

The target frequency is the largest absolute value of main frequency X and auxiliary frequency Y.

3: MIN

The target frequency is the least absolute value of main frequency X and auxiliary frequency Y.

In addition, when the frequency source selection is X and Y, offset frequency can be set by 01.21, offset frequency, superimposed on the advocate complementary operation results in a flexible response to various needs.

|       |                  |   |         |
|-------|------------------|---|---------|
| 01.08 | Preset frequency | Default   | 50.00Hz |
|       | Setting Range    | 0.00~maximum frequency (valid when frequency source is digital setting) |         |

If the frequency source is digital setting or terminal UP/DOWN, the value of this parameter is the initial frequency of the AC drive (digital setting)

|       |                    |         |                   |
|-------|--------------------|---------|-------------------|
| 01.09 | Rotation direction | Default | 0                 |
|       | Setting Range      | 0       | Same direction    |
|       |                    | 1       | Reverse direction |

You can change the rotation direction of the motor just by modifying this parameter without changing the motor wiring. Modifying this parameter is equivalent to exchanging any two of the motor's U, V, W wires.

Note: The motor will resume running in the original direction after parameter initialization. Do not use this function in applications where changing the rotating direction of the motor is prohibited after system commissioning is complete.

|       |                   |                    |          |
|-------|-------------------|--------------------|----------|
| 01.10 | Maximum frequency | Default            | 50.00 Hz |
|       | Setting Range     | 50.00Hz ~ 320.00Hz |          |

When the frequency source is AI, pulse setting (DI5), or multi-reference, 100% of the input corresponds to the value of this parameter.

The output frequency of the DSI-100 can reach up to 3200 Hz. To take both frequency reference resolution and frequency input range into consideration, you can set the number of decimal places for frequency reference in 01.22.

If 01.22 is set to 1, the frequency reference resolution is 0.1 Hz. In this case, the setting range of 01.10 is 50.0 to 3200.0 Hz.

If 01.22 is set to 2, the frequency reference resolution is 0.01 Hz. In this case, the setting range of 01.10 is 50.00 to 320.00 Hz.

|       |                                 |         |                        |
|-------|---------------------------------|---------|------------------------|
| 01.11 | Source of frequency upper limit | Default | 0                      |
|       | Setting Range                   | 0       | Set by 01.12           |
|       |                                 | 1       | VS                     |
|       |                                 | 2       | AS                     |
|       |                                 | 3       | keyboard potentiometer |
|       |                                 | 4       | PULSE setting (DI5)    |

It is used to set the source of the frequency upper limit, including digital setting (01.12), AI, pulse setting or communication setting. If the frequency upper limit is set by means of analog input, the analog input setting is 100% corresponding to 01.12.

For example, to avoid runaway in torque control mode in winding application, you can set the frequency upper limit by means of analog input. When the AC drive reaches the upper limit, it will continue to run at this speed.

|       |                              |  |         |
|-------|------------------------------|--|---------|
| 01.12 | Frequency upper limit        | Default  | 50.00Hz |
|       | Setting Range                | Frequency lower limit 01.14 ~maximum frequency 01.10 |         |
| 01.13 | Frequency upper limit offset | Default  | 0.00Hz  |
|       | Setting Range                | 0.00Hz ~maximum frequency 01.10                      |         |

If the source of the frequency upper limit is analog input or pulse setting, the final frequency upper limit is obtained by adding the offset in this parameter to the frequency upper limit set in 01.11

|       |                       |                                     |        |
|-------|-----------------------|-------------------------------------|--------|
| 01.14 | Frequency lower limit | Default                             | 0.00Hz |
|       | Setting Range         | 0.00Hz ~frequency upper limit 01.12 |        |

If the frequency reference is lower than the value of this parameter, the AC drive can stop, run at the frequency lower limit, or run at zero speed, determined by 08-14.

|       |                   |                 |                 |
|-------|-------------------|-----------------|-----------------|
| 01.15 | Carrier frequency | Default         | Model dependent |
|       | Setting Range     | 0.5kHz ~16.0kHz |                 |

It is used to adjust the carrier frequency of the AC drive, helping to reduce the motor noise, avoiding the resonance of the mechanical system, and reducing the leakage current to the earth and interference generated by the AC drive.

If the carrier frequency is low, output current has high harmonics, and the power loss and temperature rise of the motor increase.

If the carrier frequency is high, power loss and temperature rise of the motor declines.

However, the AC drive has an increase in power loss, temperature rise and interference.

Adjusting the carrier frequency will exert influences on the aspects listed in the following table:

|                                 |       |   |       |
|---------------------------------|-------|---|-------|
| Carrier frequency               | Low   | - | High  |
| Motor noise                     | Large | - | Small |
| Output current waveform         | Bad   | - | Good  |
| Motor temperature rise          | High  | - | Low   |
| AC drive temperature rise       | Low   | - | High  |
| Leakage current                 | Small | - | Large |
| External radiation interference | Small | - | Large |

The factory setting of carrier frequency varies with the AC drive power. If you need to modify the carrier frequency, note that if the set carrier frequency is higher than factory setting, it will lead to an increase in temperature rise of the AC drive's heatsink. In this case, you need to de-rate the AC drive. Otherwise, the AC drive may overheat and alarm.

|       |   |              |   |
|-------|---|--------------|---|
| 01.16 | Carrier frequency adjustment with temperature | Default      | 1 |
|       | Setting Range                                 | 0: No 1: Yes |   |

It is used to set whether the carrier frequency is adjusted based on the temperature. The AC drive automatically reduces the carrier frequency when detecting that the heatsink temperature is high. The AC drive resumes the carrier frequency to the set value when the heatsink temperature becomes normal. This function reduces the overheat alarms.

|       |                     |   |                 |
|-------|---------------------|---|-----------------|
| 01.17 | Acceleration time 1 | Default   | Model dependent |
|       | Setting Range       | 0.00s ~ 650.00s (01.19=2)<br>0.0s ~ 6500.0s (01.19=1)<br>0s ~ 65000s(01.19=0) |                 |
| 01.18 | Deceleration time 1 | Default   | Model dependent |
|       | Setting Range       | 0.00s ~ 650.00s (01.19=2)<br>0.0s ~ 6500.0s (01.19=1)<br>0s ~ 65000s(01.19=0) |                 |

Acceleration time indicates the time required by the AC drive to accelerate from 0 Hz to "Acceleration/Deceleration base frequency" (01.25), that is, t1 in below figure

Deceleration time indicates the time required by the AC drive to decelerate from "Acceleration/Deceleration base frequency" (01.25) to 0 Hz, that is, t2 in below figure.

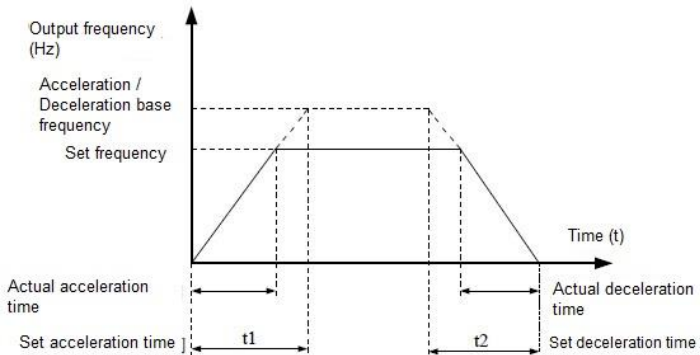

Figure Acceleration / Deceleration time

The DSI-100 provides totally four groups of acceleration/deceleration time for selection. You can perform switchover by using a DI terminal.

Group 1: 01.17, 01.18

Group 2: 09.03, 09.04

Group 3: 09.05, 09.06

Group 4: 09.07, 09.08

|       |                                     |   |         |   |
|-------|-------------------------------------|---|---------|---|
| 01.19 | Acceleration/Deceleration time unit |   | Default | 1 |
|       | Setting Range                       | 0 | 1s      |   |
|       |                                     | 1 | 0.1s    |   |
|       |                                     | 2 | 0.01s   |   |

To satisfy requirements of different applications, the DSI-100 provides three acceleration/deceleration time units, 1s, 0.1s and 0.01s.

Note:

Modifying this parameter will make the displayed decimal places change and corresponding acceleration/deceleration time also change.

|       |  |                                 |        |
|-------|--|---------------------------------|--------|
| 01.21 | Frequency offset of auxiliary frequency source for X and Y operation | Default                         | 0.00Hz |
|       | Setting Range  | 0.00Hz ~maximum frequency 01.10 |        |

This function code is only valid when the frequency source is selected as main and auxiliary operation.

When the frequency source is the main and auxiliary operation, 01.21 is used as the offset frequency, which is superimposed with the main and auxiliary operation results as the final frequency setting value, so that the frequency setting can be more flexible.

|       |                                |         |        |
|-------|--------------------------------|---------|--------|
| 01.22 | Frequency reference resolution | Default | 2      |
|       | Setting Range                  | 1       | 0.1Hz  |
|       |                                | 2       | 0.01Hz |

This parameter is used to determine the resolution of all frequency-related function codes.

When the frequency resolution is 0.1Hz, the maximum output frequency of DSI-100 can reach 3200Hz, and when the frequency resolution is 0.01Hz, the maximum output frequency of DSI-100 is 600.00Hz

Note: When modifying this function parameter, the decimal places of all frequency-related parameters will change, and the corresponding frequency value will also change. Special attention should be paid during use;

|       |   |         |               |
|-------|---|---------|---------------|
| 01.23 | Retentive of digital setting frequency upon power failure | Default | 0             |
|       | Setting Range   | 0       | Not retentive |
|       |   | 1       | Retentive     |

This parameter is valid only when the frequency source is digital setting.

If 01.23 is set to 0, the digital setting frequency value resumes to the value of 01.08 (Preset frequency) after the AC drive stops. The modification by using keys ▲ and ▼ or the terminal UP/DOWN function is cleared.

If 01.23 is set to 1, the digital setting frequency value is the set frequency at the moment when the AC drives stops. The modification by using keys ▲ and ▼ or the terminal UP/DOWN function remains effective.

|       |   |         |                         |
|-------|---|---------|-------------------------|
| 01.24 | Motor parameter group selection               | Default | 0                       |
|       | Setting Range                                 | 0       | Motor parameter group 1 |
|       |   | 1       | Reserved                |
|       |   | 2       | Reserved                |
|       |   | 3       | Reserved                |
| 01.25 | Acceleration/Deceleration time base frequency | Default | 0                       |
|       | Setting Range                                 | 0       | Maximum (01.10)         |
|       |   | 1       | Set frequency           |
|       |   | 2       | 100Hz                   |

The acceleration and deceleration time refers to the acceleration and deceleration time from zero frequency to the frequency set by 01.25. When 01.25 is selected as 1, the acceleration and deceleration time is related to the set frequency. If the set frequency changes frequently, the acceleration of the motor changes, so attention should be paid to the application.

|       |  |         |                   |
|-------|--|---------|-------------------|
| 01.26 | Base frequency for UP/DOWN modification during running | Default | 0                 |
|       | Setting Range  | 0       | Running frequency |
|       |  | 1       | Set frequency     |

This parameter is valid only when the frequency source is digital setting.

It is used to set the base frequency to be modified by using keys ▲ and ▼ or the terminal UP/DOWN function. If the running frequency and set frequency are different, there will be a large difference between the AC drive's performance during the acceleration/deceleration process.



|       |  |   |  |     |
|-------|--|---|--|-----|
| 01.27 | Binding command source to frequency source |   | Default  | 000 |
|       | Setting Range                              | Unit's digit  | Binding operation panel command to frequency source                      |     |
|       |  | 0   | No binding   |     |
|       |  | 1   | Frequency source by digital setting                                      |     |
|       |  | 2   | AI1  |     |
|       |  | 3   | AI2  |     |
|       |  | 4   | Reserved   |     |
|       |  | 5   | PULSE setting (X5)   |     |
|       |  | 6   | Multi-reference  |     |
|       |  | 7   | Simple PLC   |     |
|       |  | 8   | PID  |     |
|       |  | 9   | Communication setting  |     |
|       |  | Ten's digit   | Binding terminal command to frequency source (0-9, same as unit's digit) |     |
|       | Hundred's digit                            | Binding communication command to frequency source (0-9, same as unit's digit) |  |     |

Define the binding combination between three running command channels and nine frequency given channels to facilitate synchronous switching.

The meaning of the above frequency given channel is the same as the main frequency source X selection 01.03, please refer to the description of 01.03 function code.

Different running command channels can be bundled with the same frequency given channel.

When the command source has a bundled frequency source, the frequency source set by 01.03~01.07 will no longer work during the valid period of the command source.

|       |                               |   |                 |   |
|-------|-------------------------------|---|-----------------|---|
| 01.28 | Serial communication protocol |   | Default         | 0 |
|       | Setting Range                 | 0 | MODBUS protocol |   |
|       |                               | 1 | Reserved        |   |
|       |                               | 2 | Reserved        |   |

## Group 02: Motor 1 Parameters

|       |                      |   |                                       |                 |
|-------|----------------------|---|---------------------------------------|-----------------|
| 02.00 | Motor type selection |   | Default                               | 0               |
|       | Setting Range        | 0 | Common asynchronous motor             |                 |
|       |                      | 1 | Variable frequency asynchronous motor |                 |
|       |                      | 2 | Reserved                              |                 |
| 02.01 | Rated motor power    |   | Default                               | Model dependent |
|       | Setting Range        |   | 0.1kW ~ 1000.0kW                      |                 |
| 02.02 | Rated motor voltage  |   | Default                               | Model dependent |
|       | Setting Range        |   | 1V ~ 2000V                            |                 |

|       |                              |  |                 |
|-------|------------------------------|--|-----------------|
| 02.03 | Rated motor current          | Default  | Model dependent |
|       | Setting Range                | 0.01A ~655.35A( AC drive power <=55kW)<br>0.1A ~6553.5A( AC drive power >55kW) |                 |
| 02.04 | Rated motor frequency        | Default  | Model dependent |
|       | Setting Range                | 0.01Hz ~maximum frequency  |                 |
| 02.05 | Rated motor rotational speed | Default  | Model dependent |
|       | Setting Range                | 1rpm ~65535rpm   |                 |

Set the parameters according to the motor nameplate, no matter whether V/F control or vector control is adopted.

To achieve better V/F or vector control performance, motor auto-tuning is required. The motor auto-tuning accuracy depends on the correct setting of motor nameplate parameters.

|       |  |  |                 |
|-------|--|--|-----------------|
| 02.06 | Stator resistance<br>(asynchronous motor)              | Default  | Model dependent |
|       | Setting Range  | 0.001Ω ~65.535Ω(AC drive power ≤ 55kW)<br>0.0001Ω ~6.5535Ω(AC drive power >55kW)   |                 |
| 02.07 | Rotor resistance<br>(asynchronous motor)               | Default  | Model dependent |
|       | Setting Range  | 0.001Ω ~65.535Ω(AC drive power ≤ 55kW)<br>0.0001Ω ~6.5535Ω(AC drive power >55kW)   |                 |
| 02.08 | Leakage inductive<br>reactance<br>(asynchronous motor) | Default  | Model dependent |
|       | Setting Range  | 0.01mH ~655.35mH(AC drive power ≤ 55kW)<br>0.001mH ~65.535mH(AC drive power >55kW) |                 |
| 02.09 | Mutual inductive<br>reactance                          | Default  | Model dependent |
|       | Setting Range  | 0.1mH ~6553.5mH(AC drive power ≤ 55kW)<br>0.01mH ~655.35mH(AC drive power >55kW)   |                 |
| 02.10 | No-load current<br>(asynchronous motor)                | Default  | Model dependent |
|       | Setting Range  | 0.01A ~02-03(AC drive power ≤ 55kW)<br>0.1A ~02-03(AC drive power >55kW)           |                 |

02.06~02.10 are the parameters of the asynchronous motor, these parameters are generally not on the motor nameplate, and need to be obtained through the automatic tuning of the inverter.

Among them, "asynchronous motor static tuning" can only obtain three parameters of 02.06~02.08, and "asynchronous motor complete tuning" can obtain all the five parameters here, as well as current loop PI parameters and so on.

When changing the rated power of the motor (02.01) or the rated voltage of the motor (02.02), the inverter will automatically modify the parameter values of 02.06 to 02.10, and restore these 5 parameters to the commonly used standard Y series motor parameters.

If it is not possible to tune the asynchronous motor on site, you can enter the above corresponding function code according to the parameters provided by the motor manufacturer.

|       |                       |         |  |
|-------|-----------------------|---------|--|
| 02.37 | Auto-tuning selection | Default | 0  |
|       | Setting               | 0       | No auto-tuning                           |
|       |                       | 1       | Asynchronous motor static auto-tuning    |
|       |                       | 2       | Asynchronous motor complete auto-tuning  |
|       |                       | 3       | Static complete parameter identification |

In order to ensure the best control performance of the inverter during vector control, please disconnect the load from the motor and use rotary tuning to perform motor parameter self-learning, otherwise the vector control effect will be affected. When the motor with a large inertia load is not easy to disengage and vector control is required, please use the static complete parameter identification.

Before parameter self-learning, it is necessary to correctly set the motor type and nameplate parameters 02.00~02.05.

Tuning action description: Set the motor nameplate parameters and self-learning type, and then press the RUN key, the inverter will perform static tuning.

0: No operation, that is, tuning is prohibited.

1: Asynchronous motor static tuning 1, which is suitable for the occasions where the asynchronous motor and the large inertia load are not easy to be disengaged, and the rotation tuning cannot be performed.

2: Asynchronous motor dynamic tuning

During the dynamic tuning process, the inverter first performs static tuning, and then accelerates to 80% of the rated frequency of the motor according to the acceleration time 01.17. After maintaining for a period of time, it decelerates to stop according to the deceleration time 01.18 and ends the tuning.

3: Static complete parameter identification

It is suitable for the case of no encoder, self-learning of motor parameters when the motor is stationary (the motor may still vibrate slightly at this time, please pay attention to safety)

Action description: Set the function code to 3, then press the RUN key, the inverter will perform no-load tuning

Note: Tuning supports motor tuning in keyboard operation mode, terminal mode, and communication mode.

### Group 03 Vector Control Parameters

This group of function codes is only valid for vector control and invalid for VF control.

|       |                                |                                  |         |
|-------|--------------------------------|----------------------------------|---------|
| 03.00 | Speed loop proportional gain 1 | Default                          | 30      |
|       | Setting Range                  | 1 ~ 100                          |         |
| 03.01 | Speed loop integral time 1     | Default                          | 0.50s   |
|       | Setting Range                  | 0.01s ~ 10.00s                   |         |
| 03.02 | Switchover frequency 1         | Default                          | 5.00Hz  |
|       | Setting Range                  | 0.00 ~ 03.05                     |         |
| 03.03 | Speed loop proportional gain 2 | Default                          | 20      |
|       | Setting Range                  | 0 ~ 100                          |         |
| 03.04 | Speed loop integral time 2     | Default                          | 1.00s   |
|       | Setting Range                  | 0.01s ~ 10.00s                   |         |
| 03.05 | Switchover frequency 2         | Default                          | 10.00Hz |
|       | Setting Range                  | 03.02 ~ maximum output frequency |         |

When the inverter runs at different frequencies, different speed loop PI parameters can be selected. When the running frequency is less than the switching frequency 1 (03.02), the speed loop PI adjustment parameters are 03.00 and 03.01. When the running frequency is greater than the switching frequency 2, the speed loop PI adjustment parameters are 03.03 and 04.04. The speed loop PI parameters between switching frequency 1 and switching frequency 2 are linearly switched between two sets of PI parameters, as shown in Figure below

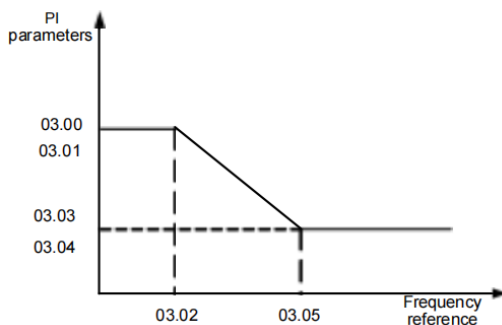

Schematic diagram of PI parameters

The speed dynamic response characteristics in vector control can be adjusted by setting the proportional gain and integral time of the speed regulator.

To achieve a faster system response, increase the proportional gain and reduce the integral time. Be aware that this may lead to system oscillation.

The recommended adjustment method is as follows:

If the factory setting cannot meet the requirements, make proper adjustment. Increase the proportional gain first to ensure that the system does not oscillate, and then reduce the integral time to ensure that the system has quick response and small overshoot.

Note: Improper PI parameter setting may cause too large speed overshoot, and over voltage fault may even occur when the overshoot drops.

|       |                     |           |      |
|-------|---------------------|-----------|------|
| 03.06 | Vector control slip | Default   | 100% |
|       | Setting Range       | 50% ~200% |      |

For SVC, it is used to adjust speed stability accuracy of the motor. When the motor with load runs at a very low speed, increase the value of this parameter; when the motor with load runs at a very large speed, decrease the value of this parameter.

For FVC, it is used to adjust the output current of the AC drive with same load.

|       |                                    |                |        |
|-------|------------------------------------|----------------|--------|
| 03.07 | Time constant of speed loop filter | Default        | 0.000s |
|       | Setting Range                      | 0.000s ~0.100s |        |

In the vector control mode, the output of the speed loop regulator is torque current reference. This parameter is used to filter the torque references. It need not be adjusted generally and can be increased in the case of large speed fluctuation. In the case of motor oscillation, decrease the value of this parameter properly.

If the value of this parameter is small, the output torque of the AC drive may fluctuate greatly, but the response is quick.

|       |                                     |         |    |
|-------|-------------------------------------|---------|----|
| 03.08 | Vector control over-excitation gain | Default | 64 |
|       | Setting Range                       | 0 ~200  |    |

During the deceleration process of the inverter, the over-excitation control can suppress the rise of the bus voltage and avoid over-voltage faults. The larger the over-excitation gain, the stronger the suppression effect.

For occasions where the inverter is prone to over-voltage alarm during deceleration, it is necessary to increase the over-excitation gain. However, if the over-excitation gain is too large, it will easily lead to an increase in the output current, which needs to be weighed in the application.

In the case of small inertia, the voltage will not rise during motor deceleration, it is recommended to set the over-excitation gain to 0; in the case of a braking resistor, it is also recommended to set the over-excitation gain to 0.

|       |   |   |                              |   |
|-------|---|---|------------------------------|---|
| 03.09 | Torque upper limit source in speed control mode |   | Default                      | 0 |
|       | Setting Range                                   | 0 | 03.10                        |   |
|       |   | 1 | AI1                          |   |
|       |   | 2 | AI2                          |   |
|       |   | 3 | AI3 (keyboard potentiometer) |   |
|       |   | 4 | PULSE setting (DI5)          |   |
| 5     | Communication setting                           |   |                              |   |

|       |   |              |        |
|-------|---|--------------|--------|
| 03.10 | Digital setting of torque upper limit in speed control mode | Default      | 150.0% |
|       | Setting Range   | 0.0% ~200.0% |        |

In the speed control mode, the maximum output torque of the AC drive is restricted by 03.09.

If the torque upper limit is analog, pulse or communication setting, 100% of the setting corresponds to the value of 03.10, and 100% of the value of 03.10 corresponds to the AC drive rated torque.

|       |   |           |      |
|-------|---|-----------|------|
| 03.13 | Excitation adjustment proportional gain | Default   | 2000 |
|       | Setting Range                           | 0 ~ 20000 |      |
| 03.14 | Excitation adjustment integral gain     | Default   | 1300 |
|       | Setting Range                           | 0 ~ 20000 |      |
| 03.15 | Torque adjustment proportional          | Default   | 2000 |
|       | Setting Range                           | 0 ~ 20000 |      |
| 03.16 | Torque adjustment integral gain         | Default   | 1300 |
|       | Setting Range                           | 0 ~ 20000 |      |

These are current loop PI parameters for vector control. These parameters are automatically obtained through "Asynchronous motor complete auto-tuning" or "Synchronous motor no-load auto-tuning", and do not need to be modified.

The dimension of the current loop integral regulator is integral gain rather than integral time.

Note that too large current loop PI gain may lead to oscillation of the entire control loop.

Therefore, when current oscillation or torque fluctuation is great, manually decrease the proportional gain or integral gain here.

#### Group 04 V/F Control Parameters

This group of function codes is only valid for V/F control and invalid for vector control.

V/F control is suitable for general-purpose loads such as fans and pumps, or one inverter with multiple motors, or applications where the power of the inverter and the motor are quite different.

|       |                    |         |                        |
|-------|--------------------|---------|------------------------|
| 04.00 | V/F curve setting  | Default | 0                      |
|       | Setting Range      | 0       | Linear VF              |
|       |                    | 1       | Multi-point VF         |
|       |                    | 2       | Square VF              |
|       |                    | 3       | 1.2-power VF           |
|       |                    | 4       | 1.4-power VF           |
|       |                    | 6       | 1.6-power VF           |
|       |                    | 8       | 1.8-power VF           |
|       |                    | 9       | Reserved               |
|       |                    | 10      | VF complete separation |
| 11    | VF half separation |         |                        |

0: Linear V/F. It is applicable to common constant torque load.

1: Multi-point VF. It is applicable to special load such as dehydrator and centrifuge. Any such VF curve can be obtained by setting parameters of 04.03~04.08.

2: Square VF. It is applicable to centrifugal loads such as fan and pump.

3~8: VF curve between linear VF and square VF

10: VF complete separation. In this mode, the output frequency and output voltage of the AC drive are independent. The output frequency is determined by the frequency source, and the output voltage is determined by "Voltage source for VF separation" (04.13).

It is applicable to induction heating, inverse power supply and torque motor control.

### 11: VF half separation

In this mode, V and F are proportional and the proportional relationship can be set in 04.13. The relationship between V and F are also related to the rated motor voltage and rated motor frequency in Group 02.

Assume that the voltage source input is X (0 to 100%), the relationship between V and F is:

$$V/F = 2 * X * (\text{Rated motor voltage}) / (\text{Rated motor frequency})$$

|       |                                   |                                  |                 |
|-------|-----------------------------------|----------------------------------|-----------------|
| 04.01 | Torque boost                      | Default                          | Model dependent |
|       | Setting Range                     | 0.0% ~30%                        |                 |
| 04.02 | Cut-off frequency of torque boost | Default                          | 50.00Hz         |
|       | Setting Range                     | 0.00Hz ~maximum output frequency |                 |

To compensate the low frequency torque characteristics of V/F control, you can boost the output voltage of the AC drive at low frequency by modifying 04.01. If the torque boost is set to too large, the motor may overheat, and the AC drive may suffer over current.

If the load is large and the motor startup torque is insufficient, increase the value of 04.01.

If the load is small, decrease the value of 04.01. If it is set to 0.0, the AC drive performs automatic torque boost. In this case, the AC drive automatically calculates the torque boost value based on motor parameters including the stator resistance.

04.02 specifies the frequency under which torque boost is valid. Torque boost becomes invalid when this frequency is exceeded, as shown in the following figure.

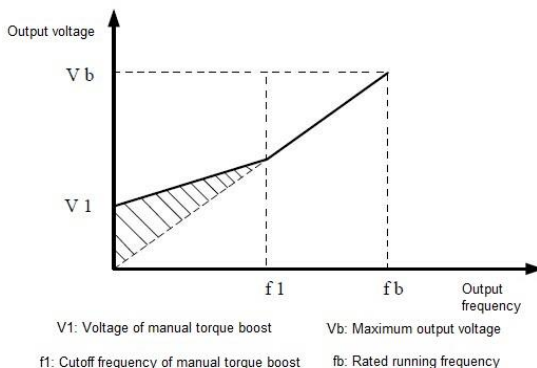

Figure Manual torque boost

|       |                             |               |        |
|-------|-----------------------------|---------------|--------|
| 04.03 | Multi-point VF frequency P1 | Default       | 0.00Hz |
|       | Setting Range               | 0.00Hz ~04.05 |        |
| 04.04 | Multi-point VF voltage V1   | Default       | 0.0%   |
|       | Setting Range               | 0.0% ~100.0%  |        |
| 04.05 | Multi-point VF frequency P2 | Default       | 0.00Hz |
|       | Setting Range               | 04.03 ~04.07  |        |
| 04.06 | Multi-point VF voltage V2   | Default       | 0.0%   |
|       | Setting Range               | 0.0% ~100.0%  |        |

|       |                             |                                     |        |
|-------|-----------------------------|-------------------------------------|--------|
| 04.07 | Multi-point VF frequency P3 | Default                             | 0.00Hz |
|       | Setting Range               | 04.05~rated motor frequency (02-04) |        |
| 04.08 | Multi-point VF voltage V3   | Default                             | 0.0%   |
|       | Setting Range               | 0.0% ~ 100.0%                       |        |

These six parameters 04.03~04.08 are used to define the multi-point VF curve.

The multi-point VF curve is set based on the motor's load characteristic. The relationship between voltages and frequencies is:

$$V1 < V2 < V3, P1 < P2 < P3$$

At low frequency, higher voltage may cause overheat or even burnt out of the motor and over current stall or over current protection of the AC drive.

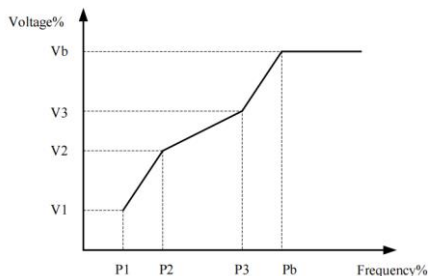

V1-V3: The percentage of the voltage of the 1st-3rd stage of the multi-points V/F

P1-P3: The percentage of the current of the 1st-3rd stage of the multi-points V/F

Vb: Motor rated voltage    Fb: Motor rated frequency

Figure Setting of multi-point VF curve

|       |                      |             |      |
|-------|----------------------|-------------|------|
| 04.09 | VF slip compensation | Default     | 0.0% |
|       | Setting Range        | 0% ~ 200.0% |      |

This parameter is valid only for the asynchronous motor.

It can compensate the rotational speed slip of the asynchronous motor when the load of the motor increases, stabilizing the motor speed in case of load change.

If this parameter is set to 100%, it indicates that the compensation when the motor bears rated load is the rated motor slip. The rated motor slip is automatically obtained by the AC drive through calculation based on the rated motor frequency and rated motor rotational speed in group 02.

Generally, if the motor rotational speed is different from the target speed, slightly adjust this parameter.

|       |                         |         |    |
|-------|-------------------------|---------|----|
| 04.10 | VF over-excitation gain | Default | 64 |
|       | Setting                 | 0 ~ 200 |    |

During deceleration of the AC drive, over-excitation can restrain rise of the bus voltage, preventing the over voltage fault. The larger the over-excitation is, the better the restraining result is.

Increase the over-excitation gain if the AC drive is liable to over voltage error during deceleration.

However, too large over-excitation gain may lead to an increase in the output current.

Set 04.09 to a proper value in actual applications.

Set the over-excitation gain to 0 in the applications where the inertia is small and the bus voltage will not rise during motor deceleration or where there is a braking resistor.

|       |                                 |         |                 |
|-------|---------------------------------|---------|-----------------|
| 04.11 | VF oscillation suppression gain | Default | Model dependent |
|       | Setting Range                   | 0 ~ 100 |                 |

Set this parameter to a value as small as possible in the prerequisite of efficient oscillation suppression to avoid influence on VF control.

Set this parameter to 0 if the motor has no oscillation. Increase the value properly only when the motor has obvious oscillation. The larger the value is, the better the oscillation suppression result will be.

When the oscillation suppression function is enabled, the rated motor current and no-load current must be correct. Otherwise, the VF oscillation suppression effect will not be satisfactory.

|   |                          |     |                              |
|---|--------------------------|-----|------------------------------|
| 04.13   | VF Voltage source for VF | Def | 0                            |
|   | Setting Range            | 0   | Digital setting (P3-14)      |
|   |                          | 1   | AI1                          |
|   |                          | 2   | AI2                          |
|   |                          | 3   | AI3 (keyboard potentiometer) |
|   |                          | 4   | PULSE setting (DI5)          |
|   |                          | 5   | Multi-reference              |
|   |                          | 6   | Simple PLC                   |
|   |                          | 7   | PID                          |
|   |                          | 8   | Communication setting        |
| 100.0% corresponds to the rated motor voltage 02.02 |                          |     |                              |

VF separation is generally applicable to scenarios such as induction heating, inverse power supply and motor torque control.

If VF separated control is enabled, the output voltage can be set in 04.14 or by means of analog, multi-reference, simple PLC, PID or communication. If you set the output voltage by means of non-digital setting, 100% of the setting corresponds to the rated motor voltage. If a negative percentage is set, its absolute value is used as the effective value.

0: Digital setting (04.14)

The output voltage is set directly in 04.14.

1: AI1 2: AI2 3: AI3 (keyboard potentiometer)

The output voltage is set by AI terminals.

4: PULSE setting (DI5)

The output voltage is set by pulses of the terminal DI5.

Pulse setting specification: voltage range 9–30 V, frequency range 0–100 kHz

5: Multi-reference

If the voltage source is multi-reference, parameters in group 04 and 13 must be set to determine the corresponding relationship between setting signal and setting voltage.

6: Simple PLC

If the voltage source is simple PLC mode, parameters in group 13 must be set to determine the setting output voltage.

7: PID

The output voltage is generated based on PID closed loop. For details, see the description of PID in group 11.

8: Communication setting

The output voltage is set by the host computer by means of communication.

When the voltage source to choose 1 ~ 8, 0 ~ 100% are corresponding to the output voltage of 0 V ~ motor rated voltage.

|       |  |         |    |
|-------|--|---------|----|
| 04.14 | VF Separation of digital voltage setting | Default | 0V |
|-------|--|---------|----|



|       |                                       |                         |      |
|-------|---------------------------------------|-------------------------|------|
|       | Setting Range                         | 0V ~Motor Rated Voltage |      |
| 04.15 | Voltage rise time of VF separation    | Default                 | 0.0s |
|       | Setting Range                         | 0.0s ~1000.0s           |      |
| 04.16 | Voltage decline time of VF separation | Default                 | 0.0s |
|       | Setting Range                         | 0.0s ~1000.0s           |      |

The voltage source for VF separation is set in the same way as the frequency source. For details, see 01.03. 100.0% of the setting in each mode corresponds to the rated motor voltage. If the corresponding value is negative, its absolute value is used

04.15 indicates the time required for the output voltage to rise from 0 V to the rated motor voltage shown as t1 in the following figure.

04.16 indicates the time required for the output voltage to decline from the rated motor voltage to 0 V, shown as t2 in the following figure.

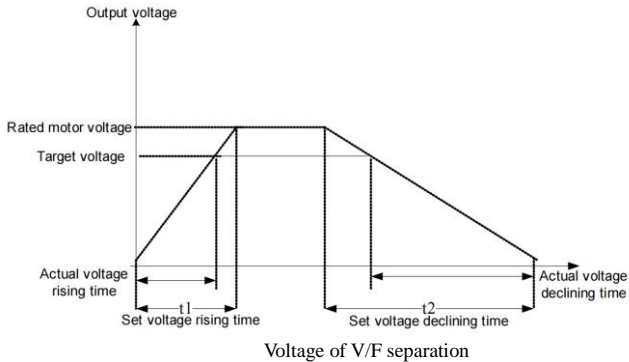

|       |                                   |  |    |
|-------|-----------------------------------|--|----|
| 04.17 | VF separation stop mode selection | Default  | 0s |
|       | Setting Range                     | 0: Frequency/voltage is reduced to 0 independently<br>1: After the voltage is reduced to 0, the frequency is reduced again |    |

0: Frequency/voltage is reduced to 0 independently

The output voltage of V/F separation is decreased to 0V according to the voltage drop time (04.15); the frequency is decreased to 0Hz according to the deceleration time (01.18) at the same time.

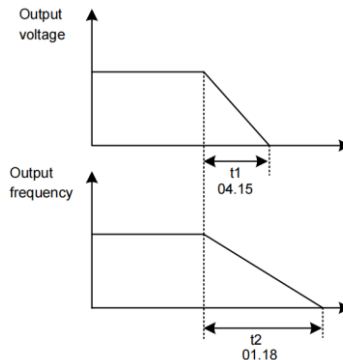

1: After the voltage is reduced to 0, the frequency is reduced

The output voltage of V/F separation is first decreased to 0V according to the voltage drop time (04.15), and then the frequency is decreased to 0Hz according to the deceleration time (01.18).

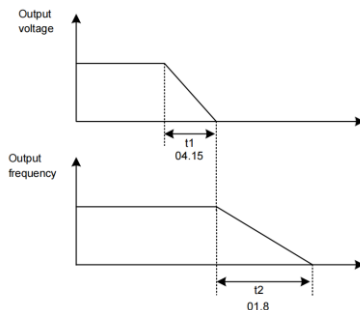
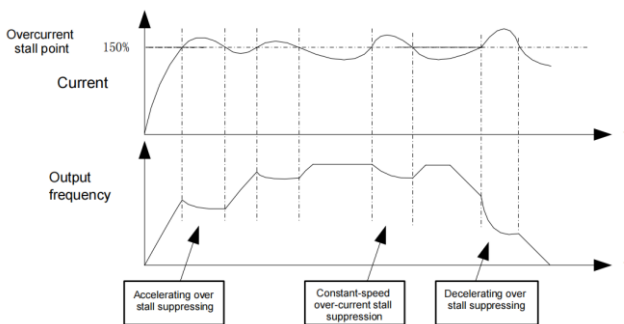

Figure Schematic diagram of successive drops of V/F separation frequency/voltage

• Inverter output current (torque) limit

During acceleration, constant speed and deceleration, if the current exceeds the overcurrent stall current point (150%), the overcurrent stall will take effect. When the current exceeds the overcurrent stall, the output frequency will begin to decrease until the current returns to the overcurrent stall. After the point is below, the frequency will start to accelerate up to the target frequency, and the actual acceleration time will be automatically extended. If the actual acceleration time cannot meet the requirements, "02.21 Overcurrent stall action current" can be appropriately increased.



Schematic diagram of overcurrent stall action

| Function Code | Function   | Setting Range | Function description  |
|---------------|--|---------------|---|
| 04.18         | Overcurrent stall action current                           | 150%          | Over-current stall suppression                              |
| 04.19         | Over-current stall suppression                             | 1             | 0 invalid, 1 valid  |
| 04.20         | Overcurrent Stall Suppression Gain                         | 20            | If the current exceeds the overcurrent stall current point, |
| 04.21         | Double-speed overcurrent stall action current compensation | 50%           | Reduce the high-speed overcurrent stall action              |

In the high frequency region, the motor drive current is small. Compared with the same stall current below the rated frequency, the speed of the motor drops greatly. In order to improve the operating characteristics of the motor, the stall action current above the rated frequency can be reduced. In some centrifuges when the operating frequency is high, several times of field weakening is required and the load inertia is large, this method has a good effect on the acceleration performance.

$$\text{Transient stall action current over rated frequency} = (f_s/f_n) * k * \text{LimitCur};$$

$f_s$  is the running frequency,  $f_n$  is the rated frequency of the motor,  $k$  is the 04.21 "double-speed overcurrent stall action current compensation coefficient", and LimitCur is 04.18 "overcurrent stall action current";

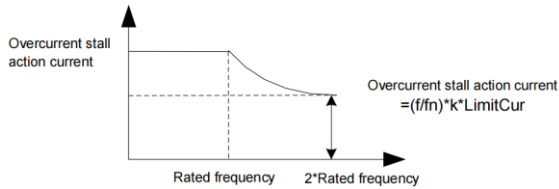

Schematic diagram of double-speed over-speed stall action

Remark:

Over-current stall action current of 150% means 1.5 times the rated current of the inverter;

For high-power motors, the carrier frequency is below 2kHz. Due to the increase of the pulsating current, the wave-by-wave current limiting response starts before the overcurrent stall prevention action, resulting in insufficient torque. In this case, please reduce the overcurrent stall prevention action current.

- Inverter bus voltage limit (and braking resistor turn-on voltage setting)

If the bus voltage exceeds the overvoltage stall point of 760V, it means that the electromechanical system is in the power generation state (motor speed > output frequency), the overvoltage stall will take effect, adjust the output frequency (consume more electricity than the feedback), and the actual deceleration time will be automatically Lengthen to avoid tripping protection. If the actual deceleration time cannot meet the requirements, the over-excitation gain can be appropriately increased.

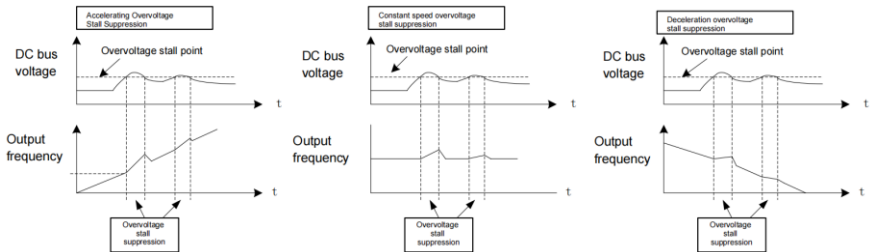

Schematic diagram of overvoltage stall action

| Function Code | Function   | Setting Range | Function description  |
|---------------|--|---------------|---|
| 04.22         | Overvoltage stall action voltage                 | 760V          |   |
| 04.23         | Over-voltage stall suppression enable            | 1             | 0 invalid, 1 valid  |
| 04.24         | Overvoltage stall suppression frequency gain     | 30            |   |
| 04.25         | Overvoltage Stall Suppression Voltage Gain       | 30            | Increasing 04.24 will improve the control effect of bus voltage. However, the output frequency will fluctuate. If the output frequency fluctuates greatly, 04.24 can be appropriately reduced. Increasing 04.2 can reduce the overshoot of bus voltage 04.25. |
| 04.26         | Overvoltage stall maximum rising frequency limit | 5Hz           | Overvoltage stall maximum rising frequency limit  |

Remark:

When using a braking resistor or adding a braking unit or using an energy regenerative unit, please pay attention:

Please set the value of 04.11 "over excitation gain" to "0", if it is not "0", it may cause the problem of excessive current during operation.

Please set the value of 04.23 "overvoltage stall enable" to "0", if it is not "0", it may cause the problem of prolonged deceleration time.

## Group 05 Input Terminals

DSI-100 series inverters are equipped with 5 multi-function digital input terminals as standard (DI5 can be used as high-speed pulse input terminal) and 2 analog input terminals.

| Function Code | Parameter Name         | Default                        | Remark   |
|---------------|------------------------|--------------------------------|----------|
| 05.00         | DI1 function selection | 1 (FWD)                        | Standard |
| 05.01         | DI2 function selection | 2 (REV)                        | Standard |
| 05.02         | DI3 function selection | 9 (Alarm reset)                | Standard |
| 05.03         | DI4 function selection | 12: Multi-reference terminal 1 | Standard |
| 05.04         | DI5 function selection | 13: Multi-reference terminal 2 | Standard |

The following table lists the functions available for the DI terminals.

| Value | Function                                   | Description  |
|-------|--|--|
| 0     | No function                                | Set 0 for reserved terminals to avoid malfunction.   |
| 1     | Forward RUN (FWD)                          | The terminal is used to control forward or reverse RUN of the AC drive.  |
| 2     | Reverse RUN (REV)                          |  |
| 3     | Three-line control                         | The terminal determines three-line control of the AC drive. For details, see the description of 05.11.   |
| 4     | Forward JOG (FJOG)                         | FJOG indicates forward JOG running, while RJOG indicates reverse JOG running. The JOG frequency, acceleration time and deceleration time are described respectively in 10.00, 10.01 and 10.02.   |
| 5     | Reverse JOG (RJOG)                         |  |
| 6     | Terminal UP                                | If the frequency is determined by external terminals, the terminals with the two functions are used as increment and decrement commands for frequency modification. When the frequency source is digital setting, they are used to adjust the frequency. |
| 7     | Terminal DOWN                              |  |
| 8     | Coast to stop                              | The AC drive blocks its output, the motor coasts to rest and is not controlled by the AC drive. It is the same as coast to stop described in 07.10.  |
| 9     | Fault reset (RESET)                        | The terminal is used for fault reset function, the same as the function of RESET key on the operation panel. Remote fault reset is implemented by this function.   |
| 10    | RUN pause                                  | The AC drive decelerates to stop, but the running parameters are all memorized, such as PLC, swing frequency and PID parameters. After this function is disabled, the AC drive resumes its status before stop.   |
| 11    | Normally open (NO) input of external fault | If this terminal becomes ON, the AC drive reports Err15 and performs the fault protection action. For more details, see the description of 10.47.  |

|    |   |  |
|----|---|--|
| 12 | Multi-reference terminal K1                       | The setting of 16 speeds or 16 other references can be implemented through combinations of 16 states of these four terminals. For more details, see appendix 1.  |
| 13 | Multi-reference terminal K2                       |  |
| 14 | Multi-reference terminal K3                       |  |
| 15 | Multi-reference terminal K4                       |  |
| 16 | Terminal 1 for ACC/DEC time selection             | Totally four groups of acceleration/deceleration time can be selected through combinations of two states of these two terminals. For more details, see appendix 2.   |
| 17 | Terminal 2 for ACC/DEC time selection             |  |
| 18 | Frequency source switchover                       | The terminal is used to perform switchover between two frequency sources according to the setting in 01.07.  |
| 19 | UP/DOWN setting clear (terminal, operation panel) | If the frequency source is digital setting, the terminal is used to clear the modification by using the UP/DOWN function or the increment/decrement key on the operation panel, returning the set frequency to the value of 01.08.   |
| 20 | Command source switchover terminal                | If the command source is set to terminal control (01.02 = 1), this terminal is used to perform switchover between terminal control and operation panel control.<br>If the command source is set to communication control (01.02 = 2), this terminal is used to perform switchover between communication control and operation panel control. |
| 21 | ACC/DEC prohibited                                | It enables the AC drive to maintain the current frequency output without being affected by external signals (except the STOP command).   |
| 22 | PID pause   | PID is invalid temporarily. The AC drive maintains the current frequency output without supporting PID adjustment of frequency source.   |
| 23 | PLC status reset                                  | The terminal is used to restore the original status of PLC control for the AC drive when PLC control is started again after a pause.   |
| 24 | Swing pause                                       | The AC drive outputs the central frequency, and the swing frequency function pauses.   |
| 25 | Counter input                                     | This terminal is used to count pulses.   |
| 26 | Counter reset                                     | This terminal is used to clear the counter status.   |
| 27 | Length count input                                | This terminal is used to count the length.   |
| 28 | Length reset                                      | This terminal is used to clear the length.   |
| 29 | Torque control prohibited                         | The AC drive is prohibited from torque control and enters the speed control mode.  |
| 30 | Pulse input (enabled only for DI5)                | DI5 is used for pulse input.   |
| 31 | Reserved  | Reserved   |
| 32 | Immediate DC braking                              | After this terminal becomes ON, the AC drive directly switches over to the DC braking state.   |
| 33 | Normally closed (NC) input of external fault      | After this terminal becomes ON, the AC drive reports Err15 and stops.  |
| 34 | Frequency modification forbidden                  | After this terminal becomes ON, the AC drive does not respond to any frequency modification.   |

|    |  |  |
|----|--|--|
| 35 | Reverse PID action direction   | After this terminal becomes ON, the PID action direction is reversed to the direction set in 11-03.  |
| 36 | External STOP terminal 1   | In operation panel mode, this terminal can be used to stop the AC drive, equivalent to the function of the STOP key on the operation panel.  |
| 37 | Command source switchover terminal 2                                 | It is used to perform switchover between terminal control and communication control. If the command source is terminal control, the system will switch over to communication control after this terminal becomes ON.                                   |
| 38 | PID integral pause   | After this terminal becomes ON, the integral adjustment function pauses. However, the proportional and differentiation adjustment functions are still valid.   |
| 39 | Switchover between main frequency source X and preset frequency      | After this terminal becomes ON, the frequency source X is replaced by the preset frequency set in 11-08.   |
| 40 | Switchover between auxiliary frequency source Y and preset frequency | After this terminal is enabled, the frequency source Y is replaced by the preset frequency set in 01.08.   |
| 41 | Reserved   | Reserved   |
| 42 | Reserved   |  |
| 43 | PID parameter switchover   | If the PID parameters switchover performed by means of DI terminal (11.18 = 1), the PID parameters are 11.05 to 11.07 when the terminal becomes OFF; the PID parameters are 11.15 to 11.17 when this terminal becomes ON.                              |
| 44 | User-defined fault 1   | If these two terminals become ON, the AC drive reports Err27 and Err28 respectively, and performs fault protection actions based on the setting in 10.49.  |
| 45 | User-defined fault 2   |  |
| 46 | Reserved   | Reserved   |
| 47 | Emergency stop   | When this terminal becomes ON, the AC drive stops within the shortest time. During the stop process, the current remains at the set current upper limit. This function is used to satisfy the requirement of stopping the AC drive in emergency state. |
| 48 | External STOP terminal 2   | In any control mode (operation panel, terminal or communication), it can be used to make the AC drive  |
| 49 | Deceleration DC braking  | When this terminal becomes ON, the AC drive decelerates to the initial frequency of stop DC braking and then switches over to DC braking state.  |
| 50 | Clear the current running time                                       | When this terminal becomes ON, the AC drive's current running time is cleared. This function must be supported by 09.42 and 09.53.   |

#### Appendix 1: State combinations of the four multi-reference terminals

The four multi-reference terminals have 16 state combinations, corresponding to 16 reference values, as listed in the following table:

| K4  | K3  | K2  | K1  | Reference Setting | Corresponding Parameter |
|-----|-----|-----|-----|-------------------|-------------------------|
| OFF | OFF | OFF | OFF | Reference 0       | 13.00                   |
| OFF | OFF | OFF | ON  | Reference 1       | 13.01                   |
| OFF | OFF | ON  | OFF | Reference 2       | 13.02                   |
| OFF | OFF | ON  | ON  | Reference 3       | 13.03                   |
| OFF | ON  | OFF | OFF | Reference 4       | 13.04                   |
| OFF | ON  | OFF | ON  | Reference 5       | 13.05                   |
| OFF | ON  | ON  | OFF | Reference 6       | 13.06                   |
| OFF | ON  | ON  | ON  | Reference 7       | 13.07                   |
| ON  | OFF | OFF | OFF | Reference 8       | 13.08                   |
| ON  | OFF | OFF | ON  | Reference 9       | 13.09                   |
| ON  | OFF | ON  | OFF | Reference 10      | 13.10                   |
| ON  | OFF | ON  | ON  | Reference 11      | 13.11                   |
| ON  | ON  | OFF | OFF | Reference 12      | 13.12                   |
| ON  | ON  | OFF | ON  | Reference 13      | 13.13                   |
| ON  | ON  | ON  | OFF | Reference 14      | 13.14                   |
| ON  | ON  | ON  | ON  | Reference 15      | 13.15                   |

If the frequency source is multi-reference, the value 100% of 13.00~13.15 corresponds to the value of 01.10 (Maximum frequency).

Besides the multi-speed function, the multi-reference can be also used as the PID setting source or the voltage source for VF separation, satisfying the requirement on switchover of different setting values.

**Appendix 2: State combinations of two terminals for acceleration/deceleration time selection**

| K2  | K1  | Acceleration/Deceleration Time Selection | Corresponding Parameters |
|-----|-----|--|--------------------------|
| OFF | OFF | Acceleration/Deceleration time 1         | 01.17, 01.18             |
| OFF | ON  | Acceleration/Deceleration time 2         | 09.03, 09.04             |
| ON  | OFF | Acceleration/Deceleration time 3         | 09.05, 09.06             |
| ON  | ON  | Acceleration/Deceleration time 4         | 09.07, 09.08             |

|       |                |                 |        |
|-------|----------------|-----------------|--------|
| 05.10 | DI filter time | Default         | 0.010s |
|       | Setting Range  | 0.000s ~ 1.000s |        |

It is used to set the software filter time of DI terminal status. If DI terminals are liable to interference and may cause malfunction, increase the value of this parameter to enhance the anti-interference capability. However, increase of DI filter time will reduce the response of DI terminals.

|       |                       |   |                   |   |
|-------|-----------------------|---|-------------------|---|
| 05.11 | Terminal command mode |   | Default           | 0 |
|       | Setting Range         | 0 | Two-line mode 1   |   |
|       |                       | 1 | Two-line mode 2   |   |
|       |                       | 2 | Three-line mode 1 |   |
|       |                       | 3 | Three-line mode 2 |   |

This parameter is used to set the mode in which the AC drive is controlled by external terminals.

**0: Two-line mode 1:**

It is the most commonly used two-line mode, in which the forward/reverse rotation of the motor is decided by

X1 and X2. The parameters are set as below:

| Function Code | Parameter Name        | Value | Function Description |
|---------------|-----------------------|-------|----------------------|
| 05.11         | Terminal command mode | 0     | Two-line 1           |
| 05.00         | X1 function selection | 1     | Forward RUN (FWD)    |
| 05.01         | X2 function selection | 2     | Reverse RUN (REV)    |

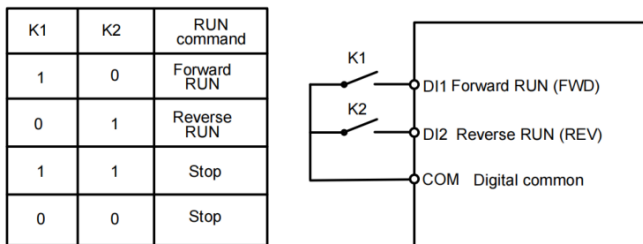

Figure Setting of two-line mode 1

### 1: Two-line mode 2

In this mode, X1 is RUN enabled terminal, and X2 determines the running direction.

The parameters are set as below:

| Function Code | Parameter Name        | Value | Function Description         |
|---------------|-----------------------|-------|------------------------------|
| 05.11         | Terminal command mode | 1     | Two-line 2                   |
| 05.00         | X1 function selection | 1     | RUN enabled                  |
| 05.01         | X2 function selection | 2     | Forward or reverse direction |

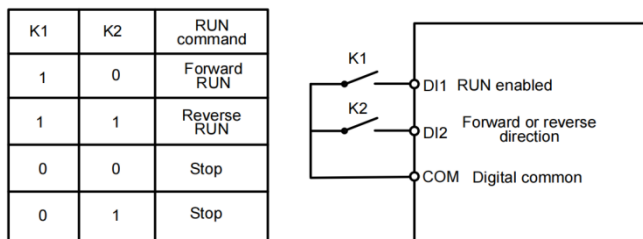

Figure Setting of two-line mode 2

As shown in the preceding figure, if K1 is ON, the AC drive instructs forward rotation when K2 is OFF, and instructs reverse rotation when K2 is ON. If K1 is OFF, the AC drive stops.

### 2: Three-line mode 1

In this mode, X3 is RUN enabled terminal, and the direction is decided by X1 and X2.

The parameters are set as below:

| Function Code | Parameter Name        | Value | Function Description |
|---------------|-----------------------|-------|----------------------|
| 05.11         | Terminal command mode | 2     | Three-line 1         |



|       |                       |   |                    |
|-------|-----------------------|---|--------------------|
| 05.00 | X1 function selection | 1 | Forward RUN (FWD)  |
| 05.01 | X2 function selection | 2 | Reverse RUN (REV)  |
| 05.02 | X3 function selection | 3 | Three-line control |

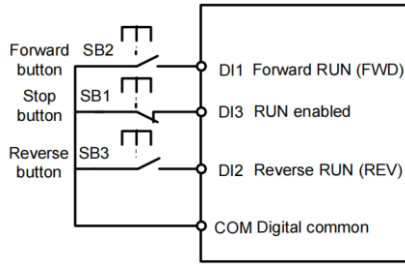

Setting of three-line mode 1

As shown in the preceding figure, if SB1 is ON, the AC drive instructs forward rotation when SB2 is pressed to be ON and instructs reverse rotation when SB3 is pressed to be ON. The AC drive stops immediately after SB1 becomes OFF. During normal startup and running, SB1 must remain ON. The AC drive's running state is determined by the final actions on SB1, SB2 and SB3.

### 3: Three-line mode 2

In this mode, X3 is RUN enabled terminal. The RUN command is given by X1 and the direction is decided by X2. The parameters are set as below:

Function Codes are set as below:

| Function Code | Parameter Name        | Value | Function Description         |
|---------------|-----------------------|-------|------------------------------|
| 05.11         | Terminal command mode | 3     | Three-line 2                 |
| 05.00         | X1 function selection | 1     | RUN enabled                  |
| 05.01         | X2 function selection | 2     | Forward or reverse direction |
| 05.02         | X3 function selection | 3     | Three-line control           |

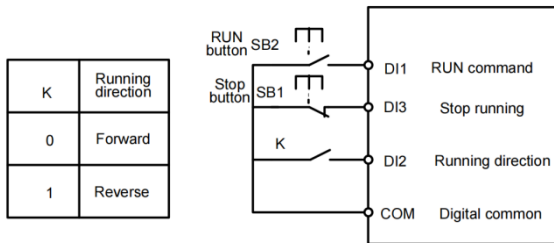

Setting of three-line mode 2

As shown in the preceding figure, if SB1 is ON, the AC drive starts running when SB2 is pressed to be ON; the AC drive instructs forward rotation when K is OFF and instructs reverse rotation when K is ON. The AC drive stops immediately after SB1 becomes OFF. During normal startup and running, SB1 must remain ON. The AC drive's running state is determined by the final actions of SB1, SB2 and K.

|       |                       |                       |          |
|-------|-----------------------|-----------------------|----------|
| 05.12 | Terminal UP/DOWN rate | Default               | 1.00Hz/s |
|       | Setting Range         | 0.01Hz/s ~ 65.535Hz/s |          |

It is used to adjust the rate of change of frequency when the frequency is adjusted by means of terminal UP/DOWN.

If 01.22 (Frequency reference resolution) is 2, the setting range is 0.001–65.535 Hz/s.

If 01.22 (Frequency reference resolution) is 1, the setting range is 0.01–655.35 Hz/s.

|       |  |                   |        |
|-------|--|-------------------|--------|
| 05.13 | AI1 curve 1 minimum input                          | Default           | 0.00V  |
|       | Setting Range                                      | 0.00V ~ 05.15     |        |
| 05.14 | Corresponding setting of AI1 curve 1 minimum input | Default           | 0.0%   |
|       | Setting Range                                      | -100.00% ~ 100.0% |        |
| 05.15 | AI1 curve 1 maximum input                          | Default           | 10.00V |
|       | Setting Range                                      | 05.13 ~ 10.00V    |        |
| 05.16 | Corresponding setting of AI1 curve 1 maximum input | Default           | 100.0% |
|       | Setting Range                                      | -100.00% ~ 100.0% |        |
| 05.17 | AI1 filter time                                    | Default           | 0.10s  |
|       | Setting Range                                      | 0.00s ~ 10.00s    |        |

These parameters are used to define the relationship between the analog input voltage and the corresponding setting.

When the analog input voltage exceeds the maximum value (05.15), the maximum value is used. When the analog input voltage is less than the minimum value (05.13), the value set in 05.34 (Setting for AI1 less than minimum input) is used.

When the analog input is current input, 1mA current corresponds to 0.5 V voltages.

05.17 (AI1 filter time) is used to set the software filter time of AI1. If the analog input is liable to interference, increase the value of this parameter to stabilize the detected analog input. However, increase of the AI filter time will slow the response of analog detection. Set this parameter properly based on actual conditions.

In different applications, 100% of analog input corresponds to different nominal values. For details, refer to the description of different applications.

Two typical setting examples are shown in the following figure.

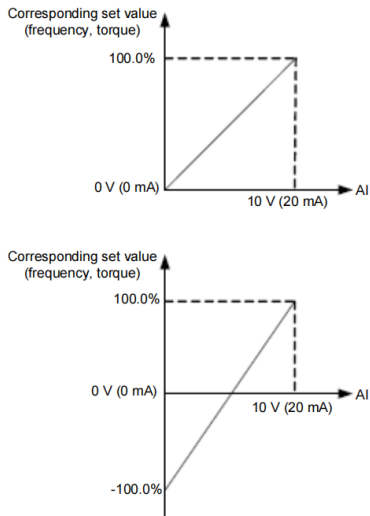

Figure Corresponding relationship between analog input and set values

|       |                         |         |       |
|-------|-------------------------|---------|-------|
| 05.18 | AI2 curve minimum input | Default | 0.00V |
|-------|-------------------------|---------|-------|

|       |  |                  |        |
|-------|--|------------------|--------|
|       | Setting Range                                    | 0.00V ~05.20     |        |
| 05.19 | Corresponding setting of AI2 curve minimum input | Default          | 0.0%   |
|       | Setting Range                                    | -100.00% ~100.0% |        |
| 05.20 | AI2 curve maximum input                          | Default          | 10.00V |
|       | Setting Range                                    | 05.18 ~10.00V    |        |
| 05.21 | Corresponding setting of AI2 curve maximum input | Default          | 100.0% |
|       | Setting Range                                    | -100.00% ~100.0% |        |
| 05.22 | AI2 filter time                                  | Default          | 0.10s  |
|       | Setting Range                                    | 0.00s ~10.00s    |        |

The method of setting AI2 functions is similar to that of setting AI1 function.

|       |  |                  |          |
|-------|--|------------------|----------|
| 05.28 | PULSE minimum input                          | Default          | 0.00kHz  |
|       | Setting Range                                | 0.00kHz ~05.30   |          |
| 05.29 | Corresponding setting of pulse minimum input | Default          | 0.0%     |
|       | Setting Range                                | -100.00% ~100.0% |          |
| 05.30 | Pulse maximum input                          | Default          | 50.00kHz |
|       | Setting Range                                | 05.28 ~50.00kHz  |          |
| 05.31 | Corresponding setting of pulse maximum input | Default          | 100.0%   |
|       | Setting Range                                | -100.00% ~100.0% |          |
| 05.32 | PULSE filter time                            | Default          | 0.10s    |
|       | Setting Range                                | 0.00s ~10.00s    |          |

These parameters are used to set the relationship between DI5 pulse input and corresponding settings. The pulses can only be input by DI5. The method of setting this function is similar to that of setting AI1 function.

|                 |                    |   |                                      |     |
|-----------------|--------------------|---|--------------------------------------|-----|
| 05.33           | AI curve selection |   | Default                              | 321 |
|                 | Setting Range      | Unit's digit                            | AI1 curve selection                  |     |
|                 |                    | 1                                       | Curve 1 (2 points, see 05.13 ~05.16) |     |
|                 |                    | 2                                       | Curve 2 (2 points, see 05.18 ~05.21) |     |
|                 |                    | 3                                       | Curve 3 (2 points, see 05.23 ~05.26) |     |
|                 |                    | 4                                       | Curve 4 (4 points, see 24.00 ~24.07) |     |
|                 |                    | 5                                       | Curve 5 (4 points, see 24.08 ~24.15) |     |
|                 | Ten's digit        | AI2 curve selection (1 ~5, same to AI1) |                                      |     |
| Hundred's digit | Reserved           |   |                                      |     |

The unit's digit, ten's digit of this parameter are respectively used to select the corresponding curve of AI1 and AI2. Any of the five curves can be selected for AI1, AI2

Curve 1&2 are all 2-point curves, set in group 05. Curve 4&5 are both 4-point curves, set in group 24.

The DSI-100 provides two AI terminals as standard.

|       |  |              |   |     |
|-------|--|--------------|---|-----|
| 05.34 | Setting for AI less than minimum input |              | Default                                 | 000 |
|       | Setting                                | Unit's digit | Setting for AI1 less than minimum input |     |

|  |       |                 |   |
|--|-------|-----------------|---|
|  | Range | 0               | Minimum value   |
|  |       | 1               | 0.0%  |
|  |       | Ten's digit     | Setting for AI2 less than minimum input<br>(0 ~ 1, same to AI1) |
|  |       | Hundred's digit | Reserved  |

This parameter is used to determine the corresponding setting when the analog input voltage is less than the minimum value. The unit's digit, ten's digit of this parameter respectively correspond to the setting for AI1 and AI2.

If the value of a certain digit is 0, when analog input voltage is less than the minimum input, the corresponding setting of the minimum input (05.14、05.19、05.24) is used.

If the value of a certain digit is 1, when analog input voltage is less than the minimum input, the corresponding value of this analog input is 0.0%.

|       |                |                |      |
|-------|----------------|----------------|------|
| 05.35 | DI1 delay time | Default        | 0.0s |
|       | Setting Range  | 0.0s ~ 3600.0s |      |
| 05.36 | DI2 delay time | Default        | 0.0s |
|       | Setting Range  | 0.0s ~ 3600.0s |      |
| 05.37 | DI3 delay time | Default        | 0.0s |
|       | Setting Range  | 0.0s ~ 3600.0s |      |

These parameters are used to set the delay time of the AC drive when the status of DI terminals changes. Currently, only DI1, DI2 and DI3 support the delay time function.

|                      |                                    |                           |                                    |       |
|----------------------|------------------------------------|---------------------------|------------------------------------|-------|
| 05.38                | Setting Range                      | DI valid mode selection 1 | Default                            | 00000 |
|                      |                                    | Unit's digit              | DI1 valid mode                     |       |
|                      |                                    | 0                         | High level valid                   |       |
|                      |                                    | 1                         | Low level valid                    |       |
|                      |                                    | Ten's digit               | DI2 valid mode (0 ~ 1, same as X1) |       |
|                      |                                    | Hundred's digit           | DI3 valid mode (0 ~ 1, same as X1) |       |
|                      |                                    | Thousand's digit          | DI4 valid mode (0 ~ 1, same as X1) |       |
| Ten thousand's digit | DI5 valid mode (0 ~ 1, same as X1) |                           |                                    |       |

It is used to set the valid state mode of the digital input terminal.

When it is selected to be active at high level, it is valid when the corresponding DI terminal is connected to COM, and invalid when disconnected.

## Group 06 Output Terminals

DSI-100 series inverters come standard with 1 multi-function AO terminal, 1 multi-function HDO terminal, and 1 multi-function Relay output terminal.

|       |  |         |   |
|-------|--|---------|---|
| 06.01 | DO function (open-collector output terminal) | Default | 0 |
| 06.02 | Relay function (T/A-T/B-T/C)                 | Default | 2 |

The above two function codes are used to select the function of two digital outputs, among which T/A-T/B-T/C are the Relays on the control board.

The function description of the multi-function output terminal is as follows:

| Value | Function                               | Description  |
|-------|--|--|
| 0     | No output                              | The terminal has no function.  |
| 1     | AC drive running                       | When the AC drive is running and has output frequency (can be zero), the terminal becomes ON.  |
| 2     | Fault output (stop)                    | When the AC drive stops due to a fault, the terminal becomes ON.   |
| 3     | Frequency-level detection FDT1 output  | Refer to the descriptions of 09.19 and 09.20.  |
| 4     | Frequency reached                      | Refer to the descriptions of 09.21.  |
| 5     | Zero-speed running (no output at stop) | If the AC drive runs with the output frequency of 0, the terminal becomes ON.<br>If the AC drive is in the stop state, the terminal becomes OFF.   |
| 6     | Motor overload pre-warning             | The AC drive judges whether the motor load exceeds the overload pre-warning threshold before performing the protection action. If the pre-warning threshold is exceeded, the terminal becomes ON. For motor overload parameters, see the descriptions of 10.00 to 10.02. |
| 7     | AC drive overload pre-warning          | The terminal becomes ON 10s before the AC drive overload protection action is performed.   |
| 8     | Set count value reached                | The terminal becomes ON when the count value reaches the value set in 12.08.   |
| 9     | Designated count value reached         | The terminal becomes ON when the count value reaches the value set in 12.09.   |
| 10    | Length reached                         | The terminal becomes ON when the detected actual length exceeds the value set in 12.05   |
| 11    | PLC cycle complete                     | When simple PLC completes one cycle, the terminal outputs a pulse signal with width of 250 ms.   |
| 12    | Accumulative running time reached      | If the accumulative running time of the AC drive exceeds the time set in 09.17, the terminal becomes ON.   |
| 13    | Frequency limited                      | If the set frequency exceeds the frequency upper limit or lower limit and the output frequency of the AC drive reaches the upper limit or lower limit, the terminal becomes ON.  |
| 14    | Torque limited                         | In speed control mode, if the output torque reaches the torque limit, the AC drive enters the stall protection state and meanwhile the terminal becomes ON.  |
| 15    | Ready for RUN                          | If the AC drive main circuit and control circuit become stable, and the AC drive detects no fault and is ready for RUN, the terminal becomes ON.   |
| 16    | AI1>AI2                                | When the input of AI1 is larger than the input of AI2, the terminal becomes ON.  |

|    |   |   |
|----|---|---|
| 17 | Frequency upper limit Reached                         | If the running frequency reaches the upper limit, the terminal becomes ON.  |
| 18 | Frequency lower limit reached (no output at stop)     | If the running frequency reaches the lower limit, the terminal becomes ON. In the stop state, the terminal becomes OFF.   |
| 19 | Undervoltage state output                             | If the AC drive is in under voltage state, the terminal becomes ON.   |
| 20 | Communication setting                                 | Refer to the communication protocol.  |
| 21 | Reserved  | Reserved.   |
| 22 | Reserved  | Reserved.   |
| 23 | Zero-speed running 2 (having output at stop)          | If the output frequency of the AC drive is 0, the terminal becomes ON. In the state of stop, the signal is still ON.  |
| 24 | Accumulative power-on time reached                    | If the AC drive accumulative power-on time (08.13) exceeds the value set in 09.16, the terminal becomes ON.   |
| 25 | Frequency level detection FDT2                        | Refer to the descriptions of 09.28 and 09.29.   |
| 26 | Frequency 1 reached                                   | Refer to the descriptions of 09.30 and 09.31.   |
| 27 | Frequency 2 reached                                   | Refer to the descriptions of 09.32 and 09.33.   |
| 28 | Current 1 reached                                     | Refer to the descriptions of 09.38 and 09.39.   |
| 29 | Current 2 reached                                     | Refer to the descriptions of 09.40 and 09.41.   |
| 30 | Timing reached  | If the timing function (09.42) is valid, the terminal becomes ON after the current running time of the AC drive reaches the set time.                                     |
| 31 | All input limit exceeded                              | If All input is larger than the value of 09.46 (All input voltage upper limit) or lower than the value of 09.45 (All input voltage lower limit), the terminal becomes ON. |
| 32 | Load becoming 0                                       | If the load becomes 0, the terminal becomes ON.   |
| 33 | Reverse running                                       | If the AC drive is in the reverse running state, the terminal Becomes ON.   |
| 34 | Zero current state                                    | Refer to the descriptions of 09.28 and 09.29.   |
| 35 | Module temperature reached                            | If the heatsink temperature of the inverter module (08.07) reaches the set module temperature threshold (09.47), the terminal becomes ON.                                 |
| 36 | Software current limit exceeded                       | Refer to the descriptions of 09.36 and 09.37.   |
| 37 | Frequency lower limit reached (having output at stop) | If the running frequency reaches the lower limit, the terminal becomes ON. In the stop state, the signal is still ON.   |
| 38 | Alarm output  | If a fault occurs on the AC drive and the AC drive continues to run, the terminal outputs the alarm signal.   |
| 39 | Reserved  | Reserved  |
| 40 | Current running time reached                          | If the current running time of AC drive exceeds the value of 09.53, the terminal becomes ON   |

|       |   |         |   |
|-------|---|---------|---|
| 06.06 | DO function selection (Pulse output terminal) | Default | 0 |
|-------|---|---------|---|

|       |                        |         |   |
|-------|------------------------|---------|---|
| 06.07 | AO1 function selection | Default | 0 |
|-------|------------------------|---------|---|

The output pulse frequency of the DO terminal ranges from 0.01 kHz to 06.09. The value of 06.09 is between 0.01 kHz and 100.00 kHz.

The output range of AO1 is 0–10 V or 0–20 mA.

The relationship between pulse and analog output ranges and corresponding functions is listed in the following table.

| Value | Function                       | Range (Corresponding to Pulse or Analog Output Range 0.0%–100.0%) |
|-------|--------------------------------|---|
| 0     | Running frequency              | 0 to maximum output frequency                                     |
| 1     | Set frequency                  | 0 to maximum output frequency                                     |
| 2     | Output current                 | 0 to 2 times of rated motor current                               |
| 3     | Output torque (absolute value) | 0 to 2 times of rated motor torque                                |
| 4     | Output power                   | 0 to 2 times of rated power                                       |
| 5     | Output voltage                 | 0 to 1.2 times of rated AC drive voltage                          |
| 6     | Pulse input                    | 0.01kHz ~100.00kHz  |
| 7     | AI1                            | 0V ~10V   |
| 8     | AI2                            | 0V ~10V (Or 0 ~20mA)  |
| 9     | Reserved                       | Reserved  |
| 10    | Length                         | 0 ~maximum set length   |
| 11    | Count value                    | 0 ~maximum count value  |
| 12    | Communication setting          | 0.0% ~100.0%  |
| 13    | Motor rotational speed         | 0 ~rotational speed corresponding to Max. output frequency        |
| 14    | Output current                 | 0.0A ~1000.0A   |
| 15    | Output voltage                 | 0.0V ~1000.0V   |

|       |                        |                  |      |
|-------|------------------------|------------------|------|
| 06.10 | AO1 offset coefficient | Default          | 0.0% |
|       | Setting Range          | -100.0% ~+100.0% |      |
| 06.11 | AO1 gain               | Default          | 1.00 |
|       | Setting Range          | -10.00 ~+10.00   |      |

These parameters are used to correct the zero drift of analog output and the output amplitude deviation. They can also be used to define the desired AO curve.

If "b" represents zero offset, "k" represents gain, "Y" represents actual output, and "X" represents standard output, the actual output is:  $Y = kX + b$ .

The zero offset coefficient 100% of AO1 and AO2 corresponds to 10 V (or 20 mA). The standard output refers to the value corresponding to the analog output of 0 to 10 V (or 0 to 20 mA) with no zero offset or gain adjustment.

For example, if the analog output is used as the running frequency, and it is expected that the output is 8 V (or 16mA)when the frequency is 0 and 3 V (or 6mA)at the maximum frequency, the gain shall be set to -0.50, and the zero offset shall be set to 80%.

Without zero offset or gain

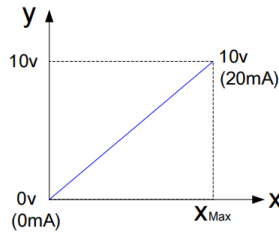

Output schematic with no offset or gain

Voltage type

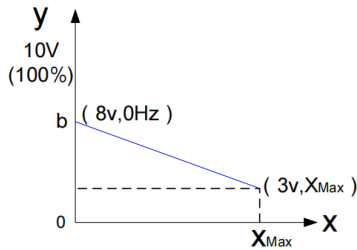

Zero offset  $b = y - kx = y (x=0) = 8v$

Zero offset coefficient is 100% corresponds to 10v, so  $b=8V$

Zero offset ratio  $= \frac{8v}{10v} \times 100\% = 80\%$

$$k = \frac{y-b}{x} = \frac{\text{actual output}-b}{\text{Standard output}} = \frac{3v-8v}{10v} = -0.5$$

Schematic diagram of output with zero offset or gain (voltage type)

Current type

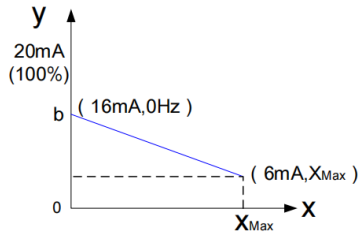

Zero offset  $b = y - kx = y (x=0) = 16mA$

Zero offset coefficient is 100% corresponds to 20mA,

so  $b=16mA$ , Zero offset ratio  $= \frac{16mA}{20mA} \times 100\% = 80\%$

$$k = \frac{y-b}{x} = \frac{\text{actual output}-b}{\text{Standard output}} = \frac{6mA-16mA}{20mA} = -0.5$$

Schematic diagram of output with zero offset or gain (Current type)



|       |                          |               |      |
|-------|--------------------------|---------------|------|
| 06.17 | HDO output delay time    | Default       | 0.0s |
|       | Setting Range            | 0.0s ~3600.0s |      |
| 06.18 | Relay1 output delay time | Default       | 0.0s |
|       | Setting Range            | 0.0s ~3600.0s |      |

These parameters are used to set the delay time of output terminals DO, Relay 1 from status change to actual output.

|       |                         |                      |                                      |       |
|-------|-------------------------|----------------------|--------------------------------------|-------|
| 06.22 | DO valid mode selection |                      | Default                              | 00000 |
|       | Setting Range           | Unit's digit         | HDO valid mode                       |       |
|       |                         | 0                    | Positive logic                       |       |
|       |                         | 1                    | Negative logic                       |       |
|       |                         | Ten's digit          | Relay1 valid mode(0 ~1, same as HDO) |       |
|       |                         | Hundred's digit      | Reserved                             |       |
|       |                         | Thousand's digit     | Reserved                             |       |
|       |                         | Ten thousand's digit | Reserved                             |       |

It is used to set the logic of output terminals HDO, Relay1.

0: Positive logic

The output terminal is valid when being connected with COM, and invalid when being disconnected from COM.

1: Negative logic

The output terminal is invalid when being connected with COM, and valid when being disconnected from COM.

## Group 07 Start/Stop Control

|       |               |   |  |   |
|-------|---------------|---|--|---|
| 07.00 | Start mode    |   | Default                                | 0 |
|       | Setting Range | 0 | Direct start                           |   |
|       |               | 1 | Rotational speed tracking restart      |   |
|       |               | 2 | Pre-excited start (asynchronous motor) |   |

0: Direct start

- If the DC braking time is set to 0, the AC drive starts to run at the startup frequency.
- If the DC braking time is not 0, the AC drive performs DC braking first and then starts to run at the startup frequency. It is applicable to small-inertia load application where the motor is likely to rotate at startup.

1: Rotational speed tracking restart

The AC drive judges the rotational speed and direction of the motor first and then starts at the tracked frequency. Such smooth start has no impact on the rotating motor. It is applicable to the restart upon instantaneous power failure of large-inertia load. To ensure the performance of rotational speed tracking restart, set the motor parameters in group P1 correctly.

2: Pre-excited start (asynchronous motor)

It is valid only for asynchronous motor and used for building the magnetic field before the motor runs. For pre-excited current and pre-excited time, see parameters of 07.05 and 07.06.

- If the pre-excited time is 0, the AC drive cancels pre-excitation and starts to run at startup frequency.
- If the pre-excited time is not 0, the AC drive pre-excites first before startup, improving the dynamic response of the motor.

|       |                                |   |                        |   |
|-------|--------------------------------|---|------------------------|---|
| 07.01 | Rotational speed tracking mode |   | Default                | 0 |
|       | Setting Range                  | 0 | From frequency at stop |   |
|       |                                | 1 | From zero speed        |   |
|       |                                | 2 | From maximum frequency |   |

To complete the rotational speed tracking process within the shortest time, select the proper mode in

which the AC drive tracks the motor rotational speed.

0: From frequency at stop

It is the commonly selected mode.

1: From zero frequency

It is applicable to restart after a long time of power failure.

2: From the maximum frequency, it is applicable to the power-generating load.

|       |                                 |         |    |
|-------|---------------------------------|---------|----|
| 07.02 | Rotational speed tracking speed | Default | 20 |
|       | Setting Range                   | 1 ~ 100 |    |

In the rotational speed tracking restart mode, select the rotational speed tracking speed. The larger the value is, the faster the tracking is. However, too large value may cause unreliable tracking.

|       |                                |                  |        |
|-------|--------------------------------|------------------|--------|
| 07.03 | Startup frequency              | Default          | 0.00Hz |
|       | Setting Range                  | 0.00Hz ~ 10.00Hz |        |
| 07.04 | Startup frequency holding time | Default          | 0.0s   |
|       | Setting Range                  | 0.0s ~ 100.0s    |        |

To ensure the motor torque at AC drive startup, set a proper startup frequency. In addition, to build excitation when the motor starts up, the startup frequency must be held for a certain period.

The startup frequency (07.03) is not restricted by the frequency lower limit. If the set target frequency is lower than the startup frequency, the AC drive will not start and stays in the standby state.

During switchover between forward rotation and reverse rotation, the startup frequency holding time is disabled. The holding time is not included in the acceleration time but in the running time of simple PLC.

Example 1:

01.03 = 0 The frequency source is digital setting.

01.08 = 2.00Hz The digital setting frequency is 2.00 Hz.

07.03 = 5.00Hz The startup frequency is 5.00 Hz.

07.04 = 2.0s The startup frequency holding time is 2.0s.

In this example, the AC drive stays in the standby state and the output frequency is 0.00 Hz.

Example 2:

01.03 = 0 The frequency source is digital setting.

01.08 = 10.00Hz The digital setting frequency is 10.00 Hz.

07.03 = 5.00Hz The startup frequency is 5.00 Hz.

07.04 = 2.0s The startup frequency holding time is 2.0s.

In this example, the AC drive accelerates to 5.00 Hz, and then accelerates to the set frequency 10.00 Hz after 2s.

Startup DC braking is generally used during restart of the AC drive after the rotating motor stops. Pre-excitation is used to make the AC drive build magnetic field for the asynchronous motor before startup to improve the responsiveness.

Startup DC braking is valid only for direct start (07.00 = 0). In this case, the AC drive performs DC braking at the set startup DC braking current. After the startup DC braking time, the AC drive starts to run. If the startup DC braking time is 0, the AC drive starts directly without DC braking. The larger the startup DC braking current is, the larger the braking force is.

If the startup mode is pre-excited start (07.00 = 3), the AC drive builds magnetic field based on the set pre-excited current. After the pre-excited time, the AC drive starts to run. If the pre-excited time is 0, the AC drive starts directly without pre-excitation.

The startup DC braking current or pre-excited current is a percentage relative to the base value.

|       |   |               |      |
|-------|---|---------------|------|
| 07.05 | Start DC braking current / pre-excitation current | Default       | 0%   |
|       | Setting Range                                     | 0% ~ 100%     |      |
| 07.06 | Start DC braking time / pre-excitation time       | Default       | 0.0s |
|       | Setting Range                                     | 0.0s ~ 100.0s |      |

Start DC braking, generally used to stop the running motor and then start it. Pre-excitation is used to

make the asynchronous motor establish a magnetic field before starting, and improve the response speed.

Start DC braking is only valid when the start mode is direct start. At this time, the inverter first performs DC braking according to the set starting DC braking current, and then starts to run after the starting DC braking time. If the DC braking time is set to 0, it will start directly without DC braking. The greater the DC braking current, the greater the braking force.

If the starting mode is asynchronous machine pre-excitation start, the inverter will first establish a magnetic field according to the set pre-excitation current, and then start running after the set pre-excitation time. If the pre-excitation time is set to 0, it will start directly without going through the pre-excitation process.

The starting DC braking current/pre-excitation current is a percentage relative to the rated current of the inverter.

|       |                                |   |                                     |   |
|-------|--------------------------------|---|-------------------------------------|---|
| 07.07 | Acceleration/Deceleration mode |   | Default                             | 0 |
|       | Setting Range                  | 0 | Linear acceleration/deceleration    |   |
|       |                                | 1 | S-curve acceleration/deceleration A |   |
|       |                                | 2 | S-curve acceleration/deceleration B |   |

It is used to set the frequency change mode during the AC drive start and stop process.

0: Linear acceleration/deceleration

The output frequency increases or decreases in linear mode. The DSI-100 provides four group of acceleration/deceleration time, which can be selected by using 05.00 to 05.08.

1: S-curve acceleration/deceleration A

The output frequency increases or decreases along the S curve. This mode is generally used in the applications where start and stop processes are relatively smooth, such as elevator and conveyor belt. 07.08 and 07.09 respectively define the time proportions of the start segment and the end segment.

2: S-curve acceleration/deceleration B

In this curve, the rated motor frequency  $f_b$  is always the inflexion point. This mode is usually used in applications where acceleration/deceleration is required at the speed higher than the rated frequency.

When the set frequency is higher than the rated frequency, the acceleration/deceleration time is:

$$t = \left( \frac{4}{9} \times \left( \frac{f}{f_b} \right)^2 + \frac{5}{9} \right) \times T$$

In the formula,  $f$  is the set frequency,  $f_b$  is the rated motor frequency and  $T$  is the acceleration time from 0 Hz to  $f_b$ .

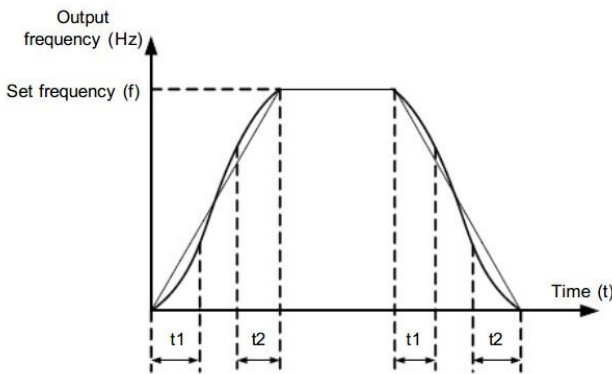

S-curve acceleration/deceleration A

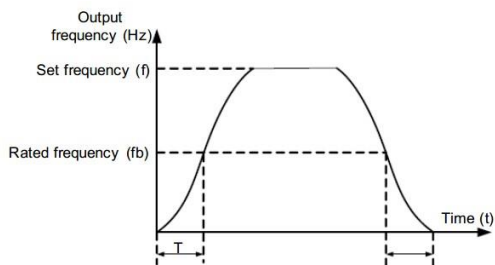

S-curve acceleration/deceleration B

|       |  |                       |       |
|-------|--|-----------------------|-------|
| 07.08 | Time proportion of S-curve start segment | Default               | 30.0% |
|       | Setting Range                            | 0.0% ~ (100.0%-07.09) |       |
| 07.09 | Time proportion of S-curve end segment   | Default               | 30.0% |
|       | Setting Range                            | 0.0% ~ (100.0%-07.08) |       |

These two parameters respectively define the time proportions of the start segment and the end segment of S-curve acceleration/deceleration. They must satisfy the requirement: 07.08 + 07.09 ≤ 100.0%.

In Figure, t1 is the time defined in 07.08, within which the slope of the output frequency change increases gradually. t2 is the time defined in 07.09, within which the slope of the output frequency change gradually decreases to 0. Within the time between t1 and t2, the slope of the output frequency change remains unchanged, that is, linear acceleration/deceleration.

|       |               |         |                    |
|-------|---------------|---------|--------------------|
| 07.10 | Stop mode     | Default | 0                  |
|       | Setting Range | 0       | Decelerate to stop |
|       |               | 1       | Coast to stop      |

0: Decelerate to stop

After the stop command is enabled, the AC drive decreases the output frequency according to the deceleration time and stops when the frequency decreases to zero.

1: Coast to stop

After the stop command is enabled, the AC drive immediately stops the output. The motor will coast to stop based on the mechanical inertia.

|       |                                      |                            |        |
|-------|--------------------------------------|----------------------------|--------|
| 07.11 | Initial frequency of stop DC braking | Default                    | 0.00Hz |
|       | Setting Range                        | 0.00Hz ~ maximum frequency |        |
| 07.12 | Waiting time of stop DC braking      | Default                    | 0.0s   |
|       | Setting Range                        | 0.0s ~ 36.0s               |        |
| 07.13 | Stop DC braking current              | Default                    | 0%     |
|       | Setting Range                        | 0% ~ 100%                  |        |
| 07.14 | Stop DC braking time                 | Default                    | 0.0s   |
|       | Setting Range                        | 0.0s ~ 36.0s               |        |

07.11 (Initial frequency of stop DC braking)

During the process of decelerating to stop, the AC drive starts DC braking when the running frequency is lower than the value set in 07.11.

07.12 (Waiting time of stop DC braking)

When the running frequency decreases to the initial frequency of stop DC braking, the AC drive stops output for a certain period and then starts DC braking. This prevents faults such as overcurrent caused due to DC braking at high speed.

07.13 (Stop DC braking current)

This parameter specifies the output current at DC braking and is a percentage relative to the base value.

– If the rated motor current is less than or equal to 80% of the rated AC drive current, the base value is the rated motor current.

– If the rated motor current is greater than 80% of the rated AC drive current, the base value is 80% of the rated AC drive current.

07.14 (Stop DC braking time)

This parameter specifies the holding time of DC braking. If it is set to 0, DC braking is cancelled.

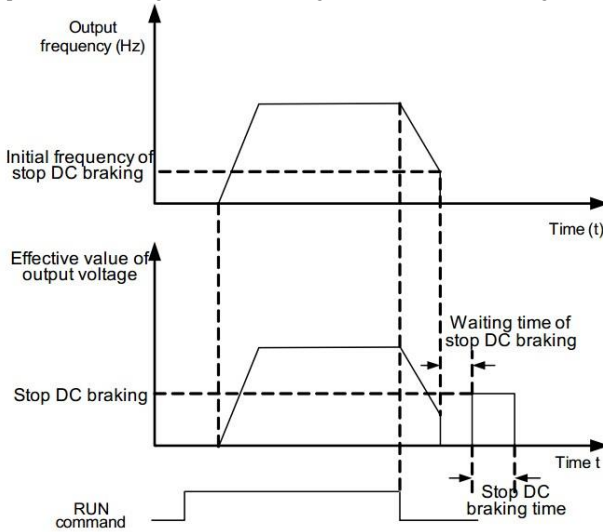

Stop DC braking process

|       |                 |          |      |
|-------|-----------------|----------|------|
| 07.15 | Brake use ratio | Default  | 100% |
|       | Setting Range   | 0% ~100% |      |

It is valid only for the AC drive with internal braking unit and used to adjust the duty ratio of the braking unit. The larger the value of this parameter is, the better the braking result will be. However, too larger value causes great fluctuation of the AC drive bus voltage during the braking process.

## Group 08 Keyboard and Display

|       |                         |         |   |
|-------|-------------------------|---------|---|
| 08.01 | MF.K function selection | Default | 0   |
|       | Setting Range           | 0       | MF key disabled   |
|       |                         | 1       | Switchover between operation panel control and remote command control (terminal or communication) |
|       |                         | 2       | Switchover between forward rotation and reverse rotation  |
|       |                         | 3       | Forward JOG   |
| 4     | Reverse JOG             |         |   |

MF.K key refers to multifunctional key. You can set the function of the MF.K key by using this parameter. You can perform switchover by using this key both in stop or running state.

0: MF.K key disabled

1: Switchover between operation panel control and remote command control (terminal or communication).

You can perform switchover from the current command source to the operation panel control (local operation). If the current command source is operation panel control, this key is invalid.

2: Switchover between forward rotation and reverse rotation

You can change the direction of the frequency reference by using the MF.K key. It is valid only when the current command source is operation panel control.

3: Forward JOG

You can perform forward JOG (FJOG) by using the MF.K key.

4: Reverse JOG

You can perform reverse JOG (RJOG) by using the MF.K key.

|       |                         |         |   |
|-------|-------------------------|---------|---|
| 08.02 | STOP/RESET key function | Default | 1   |
|       | Setting Range           | 0       | STOP/RESET key enabled only in keypad control |
|       |                         | 1       | STOP/RESET key enabled in any operation mode  |

|       |                                  |           |  |
|-------|----------------------------------|-----------|--|
| 08.03 | LED display running parameters 1 | Default   | 1F   |
|       | Setting Range                    | 0000~FFFF | <p>If a parameter needs to be displayed during the running, set the corresponding bit to 1, and set 08.03 to the hexadecimal equivalent of this binary number.</p> |

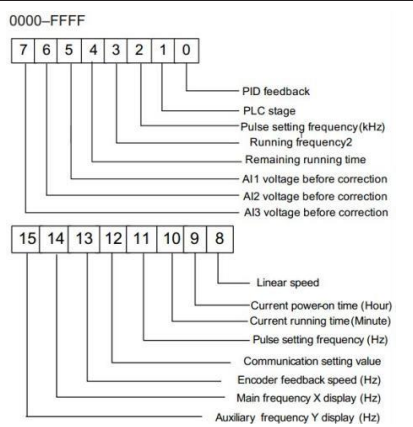
| LED display running parameters 2 |               | Default   | 0   |
|----------------------------------|---------------|-----------|---|
| 08.04                            | Setting Range | 0000~FFFF | <p>0000~FFFF</p>  <p>If a parameter needs to be displayed during the running, set the corresponding bit to 1, and set 08.03 to the hexadecimal equivalent of this binary number.</p> |

Running display parameters are used to set the parameters that can be viewed when the inverter is running.

The maximum number of status parameters available for viewing is 32. The status parameters to be displayed are selected according to the binary digits of the parameter values of 08.03 and 08.04. The display sequence starts from the lowest digit of 08.03.

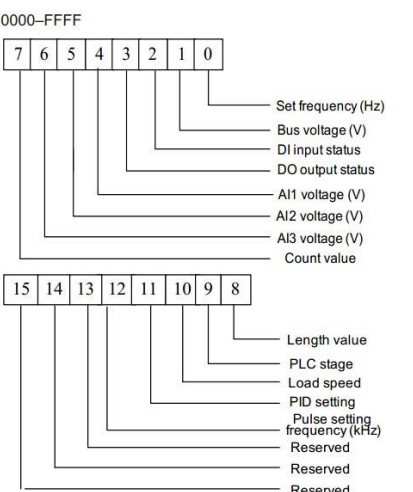
| LED display stop parameters |               | Default   | 0  |
|-----------------------------|---------------|-----------|--|
| 08.05                       | Setting Range | 0000~FFFF | <p>0000~FFFF</p>  <p>If a parameter needs to be displayed during the running, set the corresponding bit to 1, and set 08.05 to the hexadecimal equivalent of this binary number.</p> |

|       |                                |                 |        |
|-------|--------------------------------|-----------------|--------|
| 08.06 | Load speed display coefficient | Default         | 1.0000 |
|       | Setting Range                  | 0.0001 ~ 6.5000 |        |

This parameter is used to adjust the relationship between the output frequency of the AC drive and the load speed. For details, see the description of 08.12.

|       |   |               |   |
|-------|---|---------------|---|
| 08.07 | Heatsink temperature of inverter Module | Default       | — |
|       | Setting Range                           | 0.0°C~100.0°C |   |

It is used to display the insulated gate bipolar transistor (IGBT) temperature of the inverter module, and the IGBT overheat protection value of the inverter module depends on the model.

|       |                            |         |   |
|-------|----------------------------|---------|---|
| 08.08 | Temporary software version | Default | — |
|       | Setting Range              | —       |   |

It is used to display the temporary software version of the control board.

|       |                           |             |        |
|-------|---------------------------|-------------|--------|
| 08.09 | Accumulative running time | Default     | 0 hour |
|       | Setting Range             | 0h ~ 65535h |        |

It is used to display the accumulative running time of the AC drive. After the accumulative running time reaches the value set in 09.17, the terminal with the digital output function 12 becomes ON.

|       |                  |                                   |  |
|-------|------------------|-----------------------------------|--|
| 08.10 | Product number   | Default                           |  |
|       | Setting Range    | AC drive product number           |  |
| 08.11 | Software version | Default                           |  |
|       | Setting Range    | Software version of control board |  |

|       |   |   |                  |   |
|-------|---|---|------------------|---|
| 08.12 | Number of decimal places for load speed display |   | Default          | 1 |
|       | Setting Range                                   | 0 | 0 decimal place  |   |
|       |   | 1 | 1 decimal place  |   |
|       |   | 2 | 2 decimal place  |   |
|       |   | 3 | 3 decimal places |   |

08.12 is used to set the number of decimal places for load speed display. The following gives an example to explain how to calculate the load speed:

Assume that 08.06 (Load speed display coefficient) is 2.000 and 08.12 is 2 (2 decimal places).

When the running frequency of the AC drive is 40.00 Hz, the load speed is  $40.00 \times 2.000 = 80.00$  (display of 2 decimal places).

If the AC drive is in the stop state, the load speed is the speed corresponding to the set frequency, namely, "set load speed". If the set frequency is 50.00 Hz, the load speed in the stop state is  $50.00 \times 2.000 = 100.00$  (display of 2 decimal places).

|       |                            |                |   |
|-------|----------------------------|----------------|---|
| 08.13 | Accumulative power-on time | Default        | — |
|       | Setting Range              | 0 ~ 65535 hour |   |

It is used to display the accumulative power-on time of the AC drive since the delivery. If the time reaches the set power-on time (09.17), the terminal with the digital output function 24 becomes ON.

|       |                                |               |   |
|-------|--------------------------------|---------------|---|
| 08.14 | Accumulative power consumption | Default       | - |
|       | Setting Range                  | 0 ~ 65535 kWh |   |

It is used to display the accumulative power consumption of the AC drive until now.



## Group 09 Auxiliary Functions

|       |                       |                           |        |
|-------|-----------------------|---------------------------|--------|
| 09.00 | JOG running frequency | Default                   | 2.00Hz |
|       | Setting Range         | 0.00Hz ~maximum frequency |        |
| 09.01 | JOG acceleration time | Default                   | 20.0s  |
|       | Setting Range         | 0.0s ~6500.0s             |        |
| 09.02 | JOG deceleration time | Default                   | 20.0s  |
|       | Setting Range         | 0.0s ~6500.0s             |        |

These parameters are used to define the set frequency and acceleration/deceleration time of the AC drive when jogging. The startup mode is "Direct start" (07.00 = 0) and the stop mode is "Decelerate to stop" (07.10 = 0) during jogging.

|       |                     |               |                 |
|-------|---------------------|---------------|-----------------|
| 09.03 | Acceleration time 2 | Default       | Model dependent |
|       | Setting Range       | 0.0s ~6500.0s |                 |
| 09.04 | Deceleration time 2 | Default       | Model dependent |
|       | Setting Range       | 0.0s ~6500.0s |                 |
| 09.05 | Acceleration time 3 | Default       | Model dependent |
|       | Setting Range       | 0.0s ~6500.0s |                 |
| 09.06 | Deceleration time 3 | Default       | Model dependent |
|       | Setting Range       | 0.0s ~6500.0s |                 |
| 09.07 | Acceleration time 4 | Default       | Model dependent |
|       | Setting Range       | 0.0s ~6500.0s |                 |
| 09.08 | Deceleration time 4 | Default       | Model dependent |
|       | Setting Range       | 0.0s ~500.0s  |                 |

The DSI-100 provides a total of four groups of acceleration/deceleration time, that is, the preceding three groups and the group defined by 01.17 and 01.18. Definitions of four groups are completely the same. You can switch over between the four groups of acceleration/deceleration time through different state combinations of X terminals. For more details, see the descriptions of 05.01 to 05.05.

|       |                          |                            |        |
|-------|--------------------------|----------------------------|--------|
| 09.09 | Jump frequency 1         | Default                    | 0.00Hz |
|       | Setting Range            | 0.00Hz ~maximum frequency  |        |
| 09.10 | Jump frequency 2         | Default                    | 0.00Hz |
|       | Setting Range            | 0.00 Hz ~maximum frequency |        |
| 09.11 | Frequency jump amplitude | Default                    | 0.00Hz |
|       | Setting Range            | 0.00 ~maximum frequency    |        |

If the set frequency is within the frequency jump range, the actual running frequency is the jump frequency close to the set frequency. Setting the jump frequency helps to avoid the mechanical resonance point of the load.

The DSI-100 supports two jump frequencies. If both are set to 0, the frequency jump function is disabled. The principle of the jump frequencies and jump amplitude is shown in the following figure.

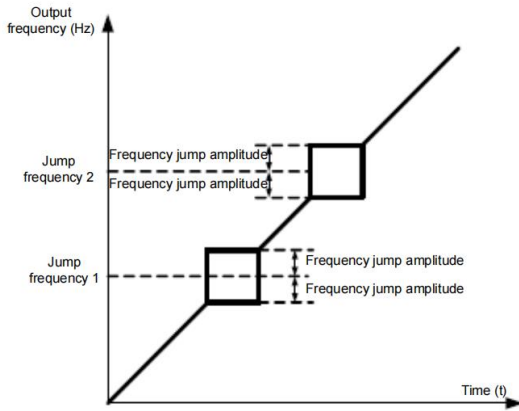

Principle of the jump frequencies and jump amplitude

|       |   |                |      |
|-------|---|----------------|------|
| 09.12 | Forward/Reverse rotation dead-zone time | Default        | 0.0s |
|       | Setting Range                           | 0.0s ~ 3000.0s |      |

It is used to set the time when the output is 0Hz at transition of the AC drive forward rotation and reverse rotation, as shown in the following figure.

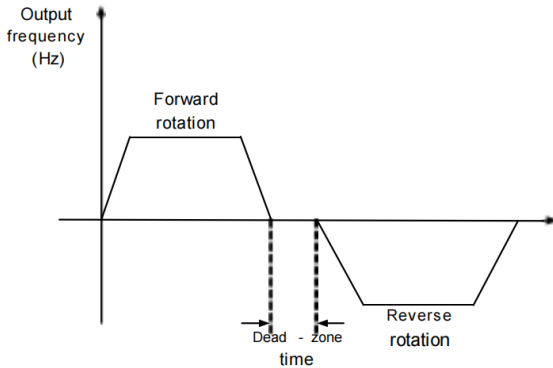

Forward/Reverse rotation dead-zone time

|       |                 |         |          |
|-------|-----------------|---------|----------|
| 09.13 | Reverse control | Default | 0        |
|       | Setting Range   | 0       | Enabled  |
|       |                 | 1       | Disabled |

It is used to set whether the AC drive allows reverse rotation. In the applications where reverse rotation is prohibited, set this parameter to 1.

|       |  |                   |                              |
|-------|--|-------------------|------------------------------|
| 09.14 | Running mode when set frequency lower than frequency lower limit | Default           | 0                            |
|       | Setting Range  | 0                 | Run at frequency lower limit |
|       |  | 1                 | Stop                         |
|       | 2  | Run at zero speed |                              |

It is used to set the AC drive running mode when the set frequency is lower than the frequency lower limit. The DSI-100 provides three running modes to satisfy requirements of various applications.

|       |               |                 |        |
|-------|---------------|-----------------|--------|
| 09.15 | Drop control  | Default         | 0.00Hz |
|       | Setting Range | 0.00Hz ~10.00Hz |        |

This function is used for balancing the workload allocation when multiple motors are used to drive the same load. The output frequency of the AC drives decreases as the load increases. You can reduce the workload of the motor under load by decreasing the output frequency for this motor, implementing workload balancing between multiple motors.

|       |                                      |            |    |
|-------|--------------------------------------|------------|----|
| 09.16 | Accumulative power-on time threshold | Default    | 0h |
|       | Setting Range                        | 0h ~65000h |    |

If the accumulative power-on time (08.13) reaches the value set in this parameter, the corresponding DO terminal becomes ON.

|       |                                     |            |    |
|-------|-------------------------------------|------------|----|
| 09.17 | Accumulative running time threshold | Default    | 0h |
|       | Setting Range                       | 0h ~65000h |    |

It is used to set the accumulative running time threshold of the AC drive. If the accumulative running time (08.09) reaches the value set in this parameter, the corresponding DO terminal becomes ON.

|       |                    |   |     |   |
|-------|--------------------|---|-----|---|
| 09.18 | Startup protection |   | D   | 0 |
|       | Setting Range      | 0 | No  |   |
|       |                    | 1 | Yes |   |

This parameter is used to set whether to enable the safety protection. If it is set to 1, the AC drive does not respond to the run command valid upon AC drive power-on (for example, an input terminal is ON before power-on). The AC drive responds only after the run command is canceled and becomes valid again.

In addition, the AC drive does not respond to the run command valid upon fault reset of the AC drive. The run protection can be disabled only after the run command is canceled.

In this way, the motor can be protected from responding to run commands upon power-on or fault reset in unexpected conditions.

|       |   |                           |         |
|-------|---|---------------------------|---------|
| 09.19 | Frequency detection value(FDT1)                   | Default                   | 50.00Hz |
|       | Setting Range                                     | 0.00Hz ~maximum frequency |         |
| 09.20 | Frequency detection hysteresis (FDT hysteresis 1) | Default                   | 5.0%    |
|       | Setting Range                                     | 0.0% ~100.0% (FDT1 level) |         |

If the running frequency is higher than the value of 09.19, the corresponding DO terminal becomes ON. If the running frequency is lower than value of 09.19, the DO terminal goes OFF

These two parameters are respectively used to set the detection value of output frequency and hysteresis value upon cancellation of the output. The value of 09.20 is a percentage of the hysteresis frequency to the frequency detection value (09.19).

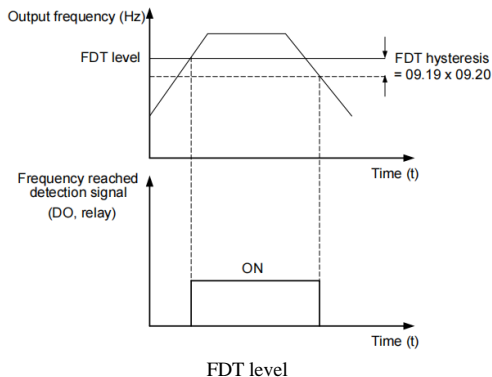

|       |                                      |                                   |      |
|-------|--------------------------------------|-----------------------------------|------|
| 09.21 | Detection range of frequency reached | Default                           | 0.0% |
|       | Setting Range                        | 0.00 ~ 100% ( maximum frequency ) |      |

If the AC drive running frequency is within the certain range of the set frequency, the corresponding DO terminal becomes ON.

This parameter is used to set the range within which the output frequency is detected to reach the set frequency. The value of this parameter is a percentage relative to the maximum frequency. The detection range of frequency reached is shown in the following figure.

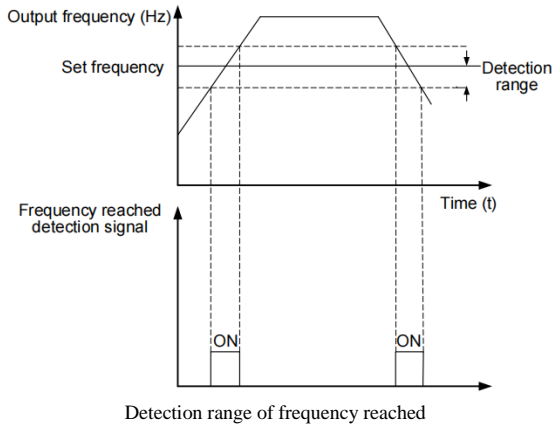

|      |   |                         |   |
|------|---|-------------------------|---|
| 9.22 | Jump frequency during acceleration/deceleration | Default                 | 0 |
|      | Setting Range                                   | 0: Disabled; 1: Enabled |   |

It is used to set whether the jump frequencies are valid during acceleration/deceleration.

When the jump frequencies are valid during acceleration/deceleration, and the running frequency is within the frequency jump range, the actual running frequency will jump over the set frequency amplitude (rise directly from the lowest jump frequency to the highest jump frequency). The following figure shows the diagram when the jump frequencies are valid during acceleration/deceleration.

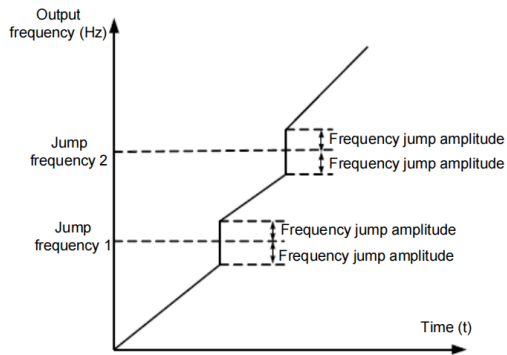
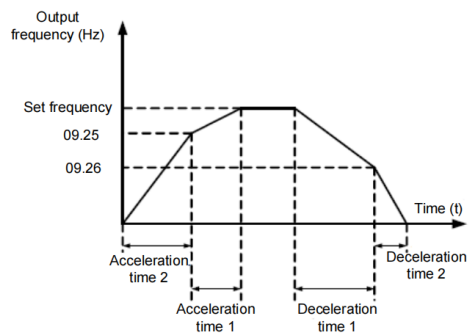

Diagram when the jump frequencies are valid during acceleration/deceleration

|       |  |                            |        |
|-------|--|----------------------------|--------|
| 09.25 | Frequency switchover point between acceleration time 1 and acceleration time 2 | Default                    | 0.00Hz |
|       | Setting Range  | 0.00Hz ~ maximum frequency |        |

|       |  |                           |        |
|-------|--|---------------------------|--------|
| 09.26 | Frequency switchover point between deceleration time 1 and deceleration time 2 | Default                   | 0.00Hz |
|       | Setting Range  | 0.00Hz ~maximum frequency |        |

This function is valid when motor 1 is selected and acceleration/deceleration time switchover is not performed by means of DI terminal. It is used to select different groups of acceleration/deceleration time based on the running frequency range rather than DI terminal during the running process of the AC drive.



Acceleration/deceleration time switchover

During acceleration, if the running frequency is smaller than the value of 09.25, acceleration time 2 is selected. If the running frequency is larger than the value of 09.25, acceleration time 1 is selected.

During deceleration, if the running frequency is larger than the value of 09.26, deceleration time 1 is selected. If the running frequency is smaller than the value of 09.26, deceleration time 2 is selected.

|       |                        |                         |   |
|-------|------------------------|-------------------------|---|
| 09.27 | Terminal JOG preferred | Default                 | 0 |
|       | Setting Range          | 0: Disabled; 1: Enabled |   |

It is used to set whether terminal JOG is preferred.

If terminal JOG is preferred, the AC drive switches to terminal JOG running state when there is a terminal JOG command during the running process of the AC drive.

|       |   |                             |         |
|-------|---|-----------------------------|---------|
| 09.28 | Frequency detection value (FDT2)                  | Default                     | 50.00Hz |
|       | Setting Range                                     | 0.00Hz ~maximum frequency   |         |
| 09.29 | Frequency detection hysteresis (FDT hysteresis 2) | Default                     | 5.0%    |
|       | Setting Range                                     | 0.0% ~100.0 % ( FDT2 level) |         |

The frequency detection function is the same as FDT1 function. For details, refer to the descriptions of 09.19 and 09.20.

|       |  |                                |         |
|-------|--|--------------------------------|---------|
| 09.30 | Any frequency reaching detection value 1     | Default                        | 50.00Hz |
|       | Setting Range                                | 0.00Hz ~maximum frequency      |         |
| 09.31 | Any frequency reaching detection amplitude 1 | Default                        | 0.0%    |
|       | Setting Range                                | 0.0%~100.0%(maximum frequency) |         |
| 09.32 | Any frequency reaching detection value 2     | Default                        | 50.00Hz |
|       | Setting Range                                | 0.00Hz ~maximum frequency      |         |
| 09.33 | Any frequency reaching detection amplitude 2 | Default                        | 0.0%    |
|       | Setting Range                                | 0.0%~100.0%(maximum frequency) |         |

If the output frequency of the AC drive is within the positive and negative amplitudes of the any frequency reaching detection value, the corresponding DO becomes ON.

The DSI-100 provides two groups of any frequency reaching detection parameters, including frequency detection value and detection amplitude, as shown in the following figure.

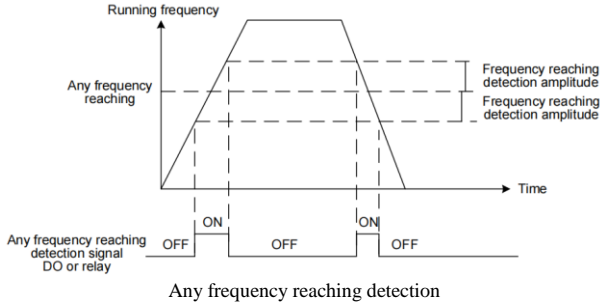

|       |                                   |                                      |       |
|-------|-----------------------------------|--------------------------------------|-------|
| 09.34 | Zero current detection level      | Default                              | 5.0%  |
|       | Setting Range                     | 0.0% ~ 300.0% ( rated motor current) |       |
| 09.35 | Zero current detection delay time | Default                              | 0.10s |
|       | Setting Range                     | 0.00s ~ 600.00s                      |       |

If the output current of the AC drive is equal to or less than the zero current detection level and the duration exceeds the zero current detection delay time, the corresponding DO becomes ON. The zero current detection is shown in the following figure.

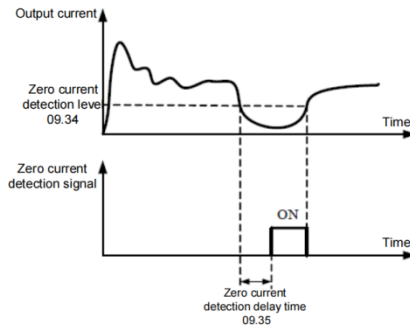

|       |                                    |  |        |
|-------|------------------------------------|--|--------|
| 09.36 | Output overcurrent threshold       | Default  | 200.0% |
|       | Setting Range                      | 0.0% ( no detection );<br>0.1% ~ 300.0% ( rated motor current) |        |
| 09.37 | Output overcurrent detection delay | Default  | 0.00s  |
|       | Setting Range                      | 0.00s ~ 600.00s  |        |

If the output current of the AC drive is equal to or higher than the overcurrent threshold and the duration exceeds the detection delay time, the corresponding DO becomes ON.

The output overcurrent detection function is shown in the following figure.

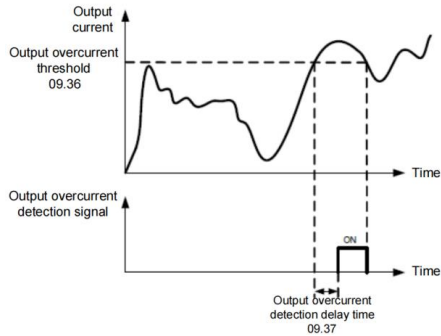

Output overcurrent detection

|       |                                  |                                      |        |
|-------|----------------------------------|--------------------------------------|--------|
| 09.38 | Any current reaching 1           | Default                              | 100.0% |
|       | Setting Range                    | 0.0% ~ 300.0%( rated motor current ) |        |
| 09.39 | Any current reaching 1 amplitude | Default                              | 0.0%   |
|       | Setting Range                    | 0.0% ~ 300.0%( rated motor current ) |        |
| 09.40 | Any current reaching 2           | Default                              | 100.0% |
|       | Setting Range                    | 0.0% ~ 300.0%( rated motor current ) |        |
| 09.41 | Any current reaching 2 amplitude | Default                              | 0.0%   |
|       | Setting Range                    | 0.0% ~ 300.0%( rated motor current ) |        |

If the output current of the AC drive is within the positive and negative amplitudes of any current reaching detection value, the corresponding DO becomes ON.

The DSI-100 provides two groups of any current reaching detection parameters, including current detection value and detection amplitudes, as shown in the following figure.

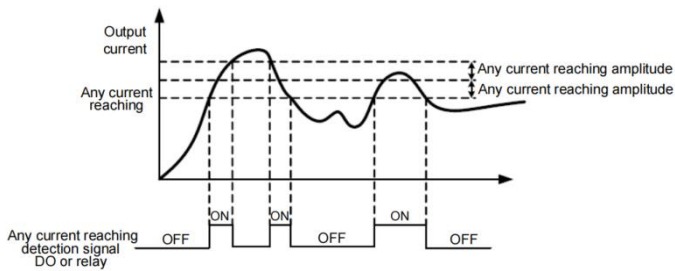

Any current reaching detection

|  |                 |         |                              |
|--|-----------------|---------|------------------------------|
| 09.42  | Timing function | Default | 0                            |
|  | Setting Range   | 0       | Disabled                     |
|  |                 | 1       | Enabled                      |
| 09.43  | Timing duration | Default | 0                            |
|  | Setting Range   | 0       | 09.44                        |
|  |                 | 1       | AI1                          |
|  |                 | 2       | AI2                          |
|  |                 | 3       | AI3 (Keyboard Potentiometer) |
| (100% of analog input corresponds to the value of 09.44) |                 |         |                              |

|       |                 |                   |        |
|-------|-----------------|-------------------|--------|
| 09.44 | Timing duration | Default           | 0.0Min |
|       | Setting Range   | 0.0Min ~6500.0Min |        |

These parameters are used to implement the AC drive timing function.

If 09.42 is set to 1, the AC drive starts to time at startup. When the set timing duration is reached, the AC drive stops automatically and meanwhile the corresponding DO becomes ON.

The AC drive starts timing from 0 each time it starts up and the remaining timing duration can be queried by 00.20.

The timing duration is set in 09.43 and 09.44, in unit of minute.

|       |                               |               |       |
|-------|-------------------------------|---------------|-------|
| 09.45 | AI1 input voltage lower limit | Default       | 3.10V |
|       | Setting Range                 | 0.00V ~09.46  |       |
| 09.46 | AI1 input voltage upper limit | Default       | 6.80V |
|       | Setting Range                 | 09.45 ~10.00V |       |

These two parameters are used to set the limits of the input voltage to provide protection on the AC drive. When the AI1 input is larger than the value of 09.46 or smaller than the value of 09.45, the corresponding DO becomes ON, indicating that VS input exceeds the limit.

|       |                              |            |      |
|-------|------------------------------|------------|------|
| 09.47 | Module temperature threshold | Default    | 75°C |
|       | Setting Range                | 0°C~ 100°C |      |

When the heatsink temperature of the AC drive reaches the value of this parameter, the corresponding DO becomes ON, indicating that the module temperature reaches the threshold.

|       |                     |   |   |
|-------|---------------------|---|---|
| 09.48 | Cooling fan control | Default   | 0 |
|       | Setting Range       | 0 : Fan working during running;<br>1 : Fan working continuously |   |

It is used to set the working mode of the cooling fan. If this parameter is set to 0, the fan works when the AC drive is in running state. When the AC drive stops, the cooling fan works if the heatsink temperature is higher than 40°C, and stops working if the heatsink temperature is lower than 40°C.

If this parameter is set to 1, the cooling fan keeps working after power-on.

|       |                              |                   |        |
|-------|------------------------------|-------------------|--------|
| 09.49 | Current running time reached | Default           | 0.0Min |
|       | Setting Range                | 0.0Min ~6500.0Min |        |



## Group 10 Faults and Protections

|       |                                     |   |              |   |
|-------|-------------------------------------|---|--------------|---|
| 10.00 | Motor overload protection selection |   | Default      | 1 |
|       | Setting Range                       | 0 | Disabled     |   |
|       |                                     | 1 | Enabled      |   |
| 10.01 | Motor overload protection gain      |   | Default      | 1 |
|       | Setting Range                       |   | 0.20 ~ 10.00 |   |

In order to effectively protect different load motors, this parameter needs to be set according to the overload capacity of the motor. The motor overload protection is an inverse time curve, and the motor overload protection curve is shown in below:

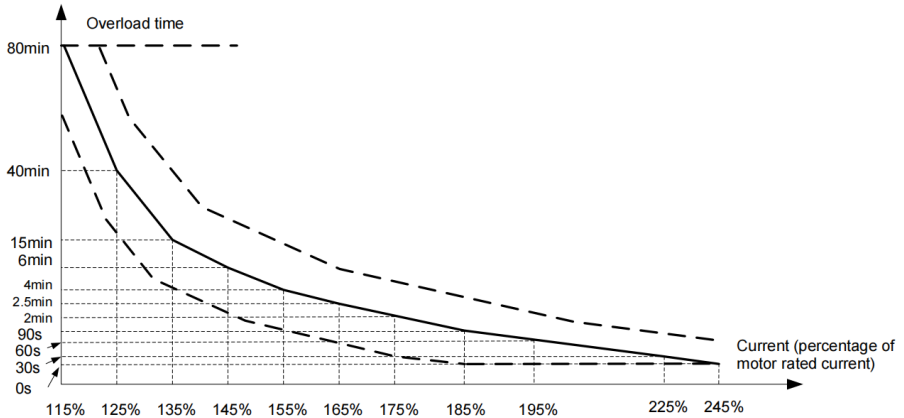

1) Under the condition that the running current of the motor reaches 175% of the rated current of the motor, the motor overload (Err11) will be reported after continuous operation for 2 minutes;

Under the condition that the running current of the motor reaches 115% times the rated current of the motor, it will report the motor overload (Err11) after continuous running for 80 minutes.

For example: motor rated current 100A

If 12.01 is set to 1.00, then when the motor running current reaches 125% (125A) of 100A, after 40 minutes, the inverter will report the motor overload fault;

If 12.01 is set to 1.20, then when the motor running current reaches 125% (125A) of 100A, after 40\*1.2=48 minutes, the inverter will report the motor overload fault;

The longest overload is 80 minutes, and the shortest time is 10 seconds.

2) Example of motor overload protection adjustment: the motor needs to run for 2 minutes under the condition of 150% motor current to report overload. It can be known from the motor overload curve that the current of 150% (I) is between 145% (I1) and 155% (I2). ) within the current range of 145% of the current for 6 minutes (T1) and 155% of the current for 4 minutes (T2), then the 5-minute overload of 150% of the motor's rated current under the default setting can be calculated as follows:

$$T = T1 + (T2 - T1) * (I - I1) / (I2 - I1) = 4 + (6 - 4) * (150 - 145) / (155 - 145) = 5 \text{ (minutes)}$$

Therefore, it can be concluded that the motor needs to report overload for 2 minutes under the condition of 150% motor current, and the motor overload protection gain is:

$$10.01 = 2 \div 5 = 0.4$$

Note: The user needs to correctly set the value of 10.01 according to the actual overload capacity of the motor. If this parameter is set too large, the motor may be overheated and damaged, and the inverter will not alarm and protect in time!

3) Motor overload warning coefficient means: when the motor overload detection level reaches the set value of this parameter, the multi-function output terminal DO or the fault relay (RELAY) outputs the motor overload pre-alarm signal. This parameter is based on the motor running continuously under a certain overload point. The time percentage calculation of overload failure is not reported.

For example: when the motor overload protection gain is set to 1.00 and the motor overload warning coefficient is set to 80%, if the motor current reaches 145% of the rated motor current and continues to run for 4.8 minutes (80% × 6 minutes), the multi-function output terminal DO Or the fault relay RELAY outputs the motor overload warning signal.

|       |  |            |     |
|-------|--|------------|-----|
| 10.02 | Motor overload pre-warning coefficient | Default    | 80% |
|       | Setting Range                          | 50% ~ 100% |     |

This function is used to give a warning signal to the control system via DO before motor overload rotection. This parameter is used to determine the percentage, at which pre-warning is performed before motor overload. The larger the value is, the less advanced the pre-warning will be.

When the accumulative output current of the AC drive is greater than the value of the overload inverse time-lag curve multiplied by 10.02, the DO terminal on the AC drive allocated with function 6 (Motor overload pre-warning) becomes ON.

|       |                                      |                              |      |
|-------|--------------------------------------|------------------------------|------|
| 10.03 | Overvoltage stall gain               | Default                      | 0    |
|       | Setting Range                        | 0 (no stall overvoltage)~100 |      |
| 10.04 | Overvoltage stall protective voltage | Default                      | 130% |
|       | Setting Range                        | 120% ~ 150%                  |      |

When the DC bus voltage exceeds the value of 10.04 (Overvoltage stall protective voltage) during deceleration of the AC drive, the AC drive stops deceleration and keeps the present running frequency. After the bus voltage declines, the AC drive continues to decelerate.

10.03 (Overvoltage stall gain) is used to adjust the overvoltage suppression capacity of the AC drive.

The larger the value is, the greater the overvoltage suppression capacity will be.

In the prerequisite of no overvoltage occurrence, set 10.03 to a small value. For small-inertia load, the value should be small. Otherwise, the system dynamic response will be slow. For large-inertia load, the value should be large. Otherwise, the suppression result will be poor and an overvoltage fault may occur.

If the overvoltage stall gain is set to 0, the overvoltage stall function is disabled.

|       |                                      |             |      |
|-------|--------------------------------------|-------------|------|
| 10.05 | Overcurrent stall gain               | Default     | 20   |
|       | Setting Range                        | 0 ~ 100     |      |
| 10.06 | Overcurrent stall protective current | Default     | 150% |
|       | Setting Range                        | 100% ~ 200% |      |

When the output current exceeds the overcurrent stall protective current during acceleration/deceleration of the AC drive, the AC drive stops acceleration/deceleration and keeps the present running frequency. After the output current declines, the AC drive continues to accelerate/decelerate.

10.05 (Overcurrent stall gain) is used to adjust the overcurrent suppression capacity of the AC drive. The larger the value is, the greater the overcurrent suppression capacity will be. In the prerequisite of no overcurrent occurrence, set 10.05 to a small value.

For small-inertia load, the value should be small. Otherwise, the system dynamic response will be slow. For large-inertia load, the value should be large. Otherwise, the suppression result will be poor and overcurrent fault may occur.

If the overcurrent stall gain is set to 0, the overcurrent stall function is disabled.

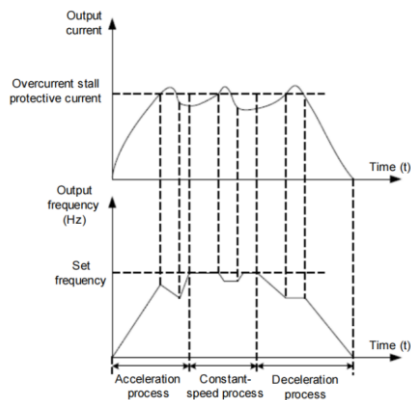

Overcurrent stall protection function

|       |                                       |                         |   |
|-------|---------------------------------------|-------------------------|---|
| 10.07 | Short-circuit to ground upon power-on | Default                 | 1 |
|       | Setting Range                         | 0: Disabled; 1: Enabled |   |

It is used to determine whether to check the motor is short-circuited to ground at power-on of the AC drive. If this function is enabled, the AC drive's UVW will have voltage output a while after power-on.

|       |                                      |               |                |
|-------|--------------------------------------|---------------|----------------|
| 10.08 | Braking unit action starting voltage | Default       | Model depended |
|       | Setting Range                        | 200.0~2000.0V |                |

The starting voltage  $V_{break}$  of the built-in braking unit action, the setting reference of this voltage value:  
 $800 \geq V_{break} \geq (1.414V_s + 30)$

$V_s$ —input AC supply voltage of inverter

Note: Improper setting of this voltage may cause the built-in braking unit to operate abnormally!

|       |                        |         |   |
|-------|------------------------|---------|---|
| 10.09 | Fault auto reset times | Default | 0 |
|       | Setting Range          | 0 ~ 20  |   |

It is used to set the times of fault auto resets if this function is used. After the value is exceeded, the AC drive will remain in the fault state.

|       |                                   |                    |   |
|-------|-----------------------------------|--------------------|---|
| 10.10 | DO action during fault auto reset | Default            | 0 |
|       | Setting Range                     | 0: Not act; 1: Act |   |

It is used to decide whether the DO acts during the fault auto reset if the fault auto reset function is selected.

|       |                                   |              |      |
|-------|-----------------------------------|--------------|------|
| 10.11 | Time interval of fault auto reset | Default      | 1.0s |
|       | Setting Range                     | 0.1s ~ 100.0 |      |

It is used to set the waiting time from the alarm of the AC drive to fault auto reset.

|       |   |   |    |
|-------|---|---|----|
| 10.12 | Input phase loss protection/contactor energizing protection selection | Default   | 11 |
|       | Setting Range   | Unit's digit: Input phase loss protection<br>Ten's digit: Contactor energizing<br>0: Disabled<br>1: Enabled |    |

Select whether to protect input phase loss or contactor pull-in.

The three-phase 380v voltage level of the DSI-100 inverter is only 18.5kw and above has the function of input phase loss protection and contactor pull-in.

Below 18.5kw, no matter if 10.12 is set to 0 or 1, there is no input phase loss, contactor pull-in combined protection function.

|       |  |                        |   |
|-------|--|------------------------|---|
| 10.13 | Output phase loss protection selection | Default                | 1 |
|       | Setting Range                          | 0: Disabled 1: Enabled |   |

Select whether to protect the output phase loss.

If you select 0 and the output phase loss actually occurs, no fault will be reported. At this time, the actual current is larger than the current displayed on the panel, and there is a risk. Use with caution.

|       |                         |        |
|-------|-------------------------|--------|
| 10.14 | 1st fault type          | 0 ~ 99 |
| 10.15 | 2nd fault type          |        |
| 10.16 | 3rd (latest) fault type |        |

It is used to record the types of the most recent three faults of the AC drive. 0 indicates no fault. For possible causes and solution of each fault, refer to alarm information for details.

|       |  |   |      |      |      |      |      |      |      |      |      |      |     |     |     |     |     |     |     |     |     |     |
|-------|--|---|------|------|------|------|------|------|------|------|------|------|-----|-----|-----|-----|-----|-----|-----|-----|-----|-----|
| 10.17 | Frequency upon 3rd fault                   | It displays the frequency when the latest fault occurs.   |      |      |      |      |      |      |      |      |      |      |     |     |     |     |     |     |     |     |     |     |
| 10.18 | Current upon 3rd fault                     | It displays the current when the latest fault occurs.   |      |      |      |      |      |      |      |      |      |      |     |     |     |     |     |     |     |     |     |     |
| 10.19 | Bus voltage upon 3rd fault                 | It displays the bus voltage when the latest fault occurs.   |      |      |      |      |      |      |      |      |      |      |     |     |     |     |     |     |     |     |     |     |
| 10.20 | Digital Input status upon 3rd fault        | <p>It displays the status of all DI terminals when the latest fault occurs. The sequence is as follows:</p> <table border="1" style="margin-left: auto; margin-right: auto;"> <tr> <td>BIT9</td><td>BIT8</td><td>BIT7</td><td>BIT6</td><td>BIT5</td><td>BIT4</td><td>BIT3</td><td>BIT2</td><td>BIT1</td><td>BIT0</td> </tr> <tr> <td>DI0</td><td>DI9</td><td>DI8</td><td>DI7</td><td>DI6</td><td>DI5</td><td>DI4</td><td>DI3</td><td>DI2</td><td>DI1</td> </tr> </table> <p>If the X terminal is ON, the setting is 1. If the X terminal is OFF, the setting is 0. The value is the equivalent decimal number converted from the X terminal status.</p> | BIT9 | BIT8 | BIT7 | BIT6 | BIT5 | BIT4 | BIT3 | BIT2 | BIT1 | BIT0 | DI0 | DI9 | DI8 | DI7 | DI6 | DI5 | DI4 | DI3 | DI2 | DI1 |
| BIT9  | BIT8                                       | BIT7  | BIT6 | BIT5 | BIT4 | BIT3 | BIT2 | BIT1 | BIT0 |      |      |      |     |     |     |     |     |     |     |     |     |     |
| DI0   | DI9  | DI8   | DI7  | DI6  | DI5  | DI4  | DI3  | DI2  | DI1  |      |      |      |     |     |     |     |     |     |     |     |     |     |
| 10.21 | Output terminal status upon 3rd fault      | <p>It displays the status of all output terminals when the latest fault occurs. The sequence is as follows:</p> <table border="1" style="margin-left: auto; margin-right: auto;"> <tr> <td>BIT4</td><td>BIT3</td><td>BIT2</td><td>BIT1</td><td>BIT0</td> </tr> <tr> <td>DO2</td><td>DO1</td><td>REL2</td><td>REL1</td><td>FMP</td> </tr> </table> <p>If an output terminal is ON, the setting is 1. If the output terminal is OFF, the setting is 0. The value is the equivalent decimal number converted from the DO terminal statuses.</p>  | BIT4 | BIT3 | BIT2 | BIT1 | BIT0 | DO2  | DO1  | REL2 | REL1 | FMP  |     |     |     |     |     |     |     |     |     |     |
| BIT4  | BIT3                                       | BIT2  | BIT1 | BIT0 |      |      |      |      |      |      |      |      |     |     |     |     |     |     |     |     |     |     |
| DO2   | DO1  | REL2  | REL1 | FMP  |      |      |      |      |      |      |      |      |     |     |     |     |     |     |     |     |     |     |
| 10.22 | AC drive status upon 3 <sup>rd</sup> Fault | Reserved  |      |      |      |      |      |      |      |      |      |      |     |     |     |     |     |     |     |     |     |     |
| 10.23 | Power-on time upon 3 <sup>rd</sup> Fault   | It displays the present power-on time when the latest fault occurs.   |      |      |      |      |      |      |      |      |      |      |     |     |     |     |     |     |     |     |     |     |
| 10.24 | Running time upon 3 <sup>rd</sup> Fault    | It displays the present running time when the latest fault occurs.  |      |      |      |      |      |      |      |      |      |      |     |     |     |     |     |     |     |     |     |     |
| 10.27 | Frequency upon 2nd fault                   | Same as 10.17~10.24   |      |      |      |      |      |      |      |      |      |      |     |     |     |     |     |     |     |     |     |     |
| 10.28 | Current upon 2nd fault                     |   |      |      |      |      |      |      |      |      |      |      |     |     |     |     |     |     |     |     |     |     |
| 10.29 | Bus voltage upon 2nd fault                 |   |      |      |      |      |      |      |      |      |      |      |     |     |     |     |     |     |     |     |     |     |
| 10.30 | Second fault input terminal                |   |      |      |      |      |      |      |      |      |      |      |     |     |     |     |     |     |     |     |     |     |
| 10.31 | Second fault output terminal               |   |      |      |      |      |      |      |      |      |      |      |     |     |     |     |     |     |     |     |     |     |
| 10.32 | Second fault inverter state                |   |      |      |      |      |      |      |      |      |      |      |     |     |     |     |     |     |     |     |     |     |
| 10.33 | Second fault power-on time                 |   |      |      |      |      |      |      |      |      |      |      |     |     |     |     |     |     |     |     |     |     |
| 10.34 | Second fault running time                  |   |      |      |      |      |      |      |      |      |      |      |     |     |     |     |     |     |     |     |     |     |

|       |                             |                     |
|-------|-----------------------------|---------------------|
| 10.37 | First fault frequency       | Same as 10.17~10.24 |
| 10.38 | First fault current         |                     |
| 10.39 | First fault bus voltage     |                     |
| 10.40 | First fault input terminal  |                     |
| 10.41 | First fault output terminal |                     |
| 10.42 | First fault inverter state  |                     |
| 10.43 | First fault power-on time   |                     |
| 10.44 | First fault running time    |                     |

|                      |                                     |   |  |       |
|----------------------|-------------------------------------|---|--|-------|
| 10.47                | Fault protection action selection 1 |   | Default  | 00000 |
|                      | Setting Range                       | Unit's digit  | Motor overload (Err11)   |       |
|                      |                                     | 0   | Coast to stop  |       |
|                      |                                     | 1   | Stop according to the stop mode                                |       |
|                      |                                     | 2   | Continue to run  |       |
|                      |                                     | Ten's digit   | Power input phase loss (Err12)                                 |       |
|                      |                                     | Hundred's digit   | Power output phase loss (Err13)                                |       |
|                      |                                     | Thousand's digit  | External equipment fault (Err15)                               |       |
| Ten thousand's digit |                                     | Communication fault (Err16)<br>(Same as unit's digit)                     |  |       |
| 10.48                | Fault protection action selection 2 |   | Default  | 00000 |
|                      | Setting Range                       | Unit's digit  | Encoder fault (Err20)  |       |
|                      |                                     | 0   | Coast to stop  |       |
|                      |                                     | 1   | Switch over to V/F control, stop according to the              |       |
|                      |                                     | 2   | Switch over to V/F control, continue to run                    |       |
|                      |                                     | Ten's digit   | EEPROM read-write fault (Err21)                                |       |
|                      |                                     | 0   | Coast to stop  |       |
|                      |                                     | 1   | Stop according to the stop mode                                |       |
|                      |                                     | Hundred's digit   | Reserved   |       |
|                      |                                     | Thousand's digit  | Motor overheat (Err25) (Same as unit's digit in                |       |
| Ten thousand's digit |                                     | Accumulative running time reached (Err26) (Same as unit's digit in 10.47) |  |       |
| 10.49                | Fault protection action selection 3 |   | Default  | 00000 |
|                      | Setting Range                       | Unit's digit  | User-defined fault 1 (Err27)<br>Same as unit's digit in 10.-47 |       |
|                      |                                     | Ten's digit   | User-defined fault 2 (Err28)<br>Same as unit's digit in 10.-47 |       |

|       |                                     |                      |   |
|-------|-------------------------------------|----------------------|---|
|       |                                     | Hundred's digit      | Accumulative power-on time reached (Err29) Same as unit's digit in 10.-47                           |
|       |                                     | Thousand's digit     | Load becoming 0 (Err30)   |
|       |                                     | 0                    | Coast to stop   |
|       |                                     | 1                    | Stop according to the stop mode   |
|       |                                     | 2                    | Continue to run at 7% of rated motor frequency and resume to the set frequency if the load Recovers |
|       |                                     | Ten thousand's digit | PID feedback lost during running (Err31) Same as unit's digit in 10.-47                             |
|       | Fault protection action selection 4 | Default              | 00000   |
| 10.50 | Setting Range                       | Unit's digit         | Too large speed deviation, (Err42) Same as unit's digit in 10.47                                    |
|       |                                     | Ten's digit          | Motor over-speed (Err43) Same as unit's digit in 10.47  |
|       |                                     | Hundred's digit      | Initial position fault (Err51) Same as unit's digit in 10.47  |
|       |                                     | Thousand's digit     | Speed feedback fault (Err52) Same as unit's digit in 10.47  |
|       |                                     | Ten thousand's digit | Reserved  |

- If "Coast to stop" is selected, the AC drive displays Err\*\* and directly stops.
- If "Stop according to the stop mode" is selected, the AC drive displays A\*\* and stops according to the stop mode. After stop, the AC drive displays Err\*\*.
- If "Continue to run" is selected, the AC drive continues to run and displays A\*\*. The running frequency is set in 10.54.

|       |  |   |                                   |        |
|-------|--|---|-----------------------------------|--------|
| 10.54 | Frequency selection for continuing to run upon fault |   | Default                           | 0      |
|       | Setting Range  | 0 | Current running frequency         |        |
|       |  | 1 | Set frequency                     |        |
|       |  | 2 | Frequency upper limit             |        |
|       |  | 3 | Frequency lower limit             |        |
|       |  | 4 | Backup frequency upon abnormality |        |
| 10.55 | Backup frequency upon abnormality                    |   | Default                           | 100.0% |
|       | Setting Range  |   | 0.0% ~ 100.0%(maximum frequency)  |        |

If a fault occurs during the running of the AC drive and the handling of fault is set to "Continue to run", the AC drive displays A\*\* and continues to run at the frequency set in 10.54. The setting of 10.55 is a percentage relative to the maximum frequency.

|       |   |   |   |       |
|-------|---|---|---|-------|
| 10.59 | Action selection at instantaneous power failure             |   | Default                                 | 0     |
|       | Setting Range   | 0 | Invalid                                 |       |
|       |   | 1 | Decelerate                              |       |
|       |   | 2 | Decelerate to stop                      |       |
| 10.60 | Action pause judging voltage at instantaneous power failure |   | Default                                 | 90.0% |
|       | Setting Range   |   | 80.0% ~ 100.0%                          |       |
| 10.61 | Voltage rally judging time at instantaneous power failure   |   | Default                                 | 0.50s |
|       | Setting Range   |   | 0.00s ~ 100.00s                         |       |
| 10.62 | Action judging voltage at instantaneous power failure       |   | Default                                 | 80.0% |
|       | Setting Range   |   | 60.0% ~ 100.0% ( standard bus voltage ) |       |

Upon instantaneous power failure or sudden voltage dip, the DC bus voltage of the AC drive reduces. This function enables the AC drive to compensate the DC bus voltage reduction with the load feedback energy by reducing the output frequency so as to keep the AC drive running continuously.

- If 10.59 = 1, upon instantaneous power failure or sudden voltage dip, the AC drive decelerates. Once the bus voltage resumes to normal, the AC drive accelerates to the set frequency. If the bus voltage remains normal for the time exceeding the value set in 10.61, it is considered that the bus voltage resumes to normal.
- If 10.59 = 2, upon instantaneous power failure or sudden voltage dip, the AC drive decelerates to stop.

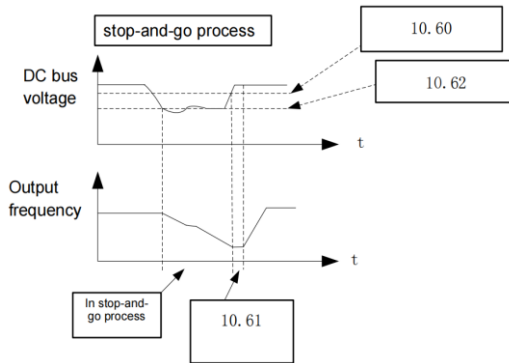

AC drive action diagram upon instantaneous power failure

Remark:

(1) In the case of constant bus voltage control, when the power grid is restored, the output frequency of the inverter will continue to run to the target frequency. In deceleration stop mode, when the power grid is restored, the inverter will continue to decelerate to 0Hz and stop until the inverter sends a start command again. .

(2) The purpose of non-stop instantaneous power failure is to ensure that when the power supply of the grid is abnormal, the motor can decelerate and stop normally, so that after the power grid returns to normal power supply, the motor can be started immediately, and the motor will not suddenly owe when the power supply of the grid is abnormal. In the large inertia system, it takes a long time for the motor to coast to stop. When the power supply is normal, since the motor is still rotating at a high speed, starting the motor at this time will easily cause the inverter to generate an overload or overcurrent fault.

|       |                                    |   |                                     |       |
|-------|------------------------------------|---|-------------------------------------|-------|
| 10.63 | Protection upon load becoming 0    |   | Default                             | 0     |
|       | Setting Range                      | 0 | Disabled                            |       |
|       |                                    | 1 | Enabled                             |       |
| 10.64 | Detection level of load becoming 0 |   | Default                             | 10.0% |
|       | Setting Range                      |   | 0.0% ~ 100.0% (rated motor current) |       |
| 10.65 | Detection time of load becoming 0  |   | Default                             | 1.0s  |
|       | Setting Range                      |   | 0.0s ~ 60.0s                        |       |

If protection upon load becoming 0 is enabled, when the output current of the AC drive is lower than the detection level (10.64) and the lasting time exceeds the detection time (10.65), the output frequency of the AC drive automatically declines to 7% of the rated frequency. During the protection, the AC drive automatically accelerates to the set frequency if the load resumes to normal.

|       |                            |  |                                   |       |
|-------|----------------------------|--|-----------------------------------|-------|
| 10.67 | Over-speed detection value |  | Default                           | 20.0% |
|       | Setting Range              |  | 0.0% ~ 50.0% ( maximum frequency) |       |
| 10.68 | Over-speed detection time  |  | Default                           | 1.0s  |
|       | Setting Range              |  | 0.0s ~ 60.0s                      |       |

This function is valid only when the AC drive runs in the CLVC mode. If the actual motor rotational speed detected by the AC drive exceeds the maximum frequency and the excessive value is greater than the value of 10.67 and the lasting time exceeds the value of 10.68, the AC drive reports Err43 and acts according to the selected fault protection action.

If the over-speed detection time is 0.0s, the over-speed detection function is disabled.

### Group 11 Process Control PID Functions

PID control is a general process control method. By performing proportional, integral and differential operations on the difference between the feedback signal and the target signal, it adjusts the output frequency and constitutes a feedback system to stabilize the controlled counter around the target value.

It is applied to process control such as flow control, pressure control and temperature control. The following figure shows the principle block diagram of PID control.

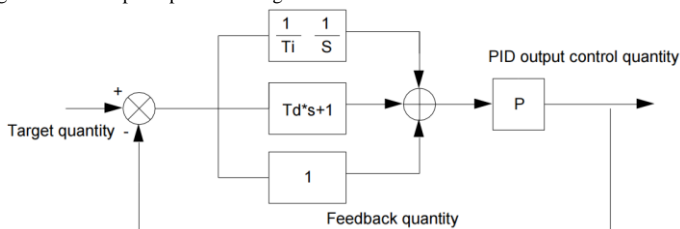

Principle block diagram of PID control

|       |                    |   |                              |   |
|-------|--------------------|---|------------------------------|---|
| 11.00 | PID setting source |   | Default                      | 0 |
|       | Setting Range      | 0 | 11.01 Setting                |   |
|       |                    | 1 | AI1                          |   |
|       |                    | 2 | AI2                          |   |
|       |                    | 3 | AI3 (Keyboard Potentiometer) |   |
|       |                    | 4 | PULSE Pulse (DI5)            |   |
|       |                    | 5 | Communication                |   |
|       |                    | 6 | Multi-reference              |   |



|       |                     |               |       |
|-------|---------------------|---------------|-------|
| 11.01 | PID digital setting | Default       | 50.0% |
|       | Setting range       | 0.0% ~ 100.0% |       |

11.00 is used to select the channel of target process PID setting. The PID setting is a relative value and ranges from 0.0% to 100.0%. The PID feedback is also a relative value.

The purpose of PID control is to make the PID setting and PID feedback equal.

|       |                     |   |                              |   |
|-------|---------------------|---|------------------------------|---|
| 11.02 | PID Feedback source |   | Default                      | 0 |
|       | Setting range       | 0 | AI1                          |   |
|       |                     | 1 | AI2                          |   |
|       |                     | 2 | AI3 (Keyboard Potentiometer) |   |
|       |                     | 3 | AI1-AI2                      |   |
|       |                     | 4 | PULSE Pulse ( DI5 )          |   |
|       |                     | 5 | Communication                |   |
|       |                     | 6 | AI1+AI2                      |   |
|       |                     | 7 | MAX( AI1 , AI2 )             |   |
|       |                     | 8 | MIN ( AI1 , AI2 )            |   |

This parameter is used to select the feedback signal channel of process PID.

The PID feedback is a relative value and ranges from 0.0% to 100.0%.

|       |                      |   |                  |   |
|-------|----------------------|---|------------------|---|
| 11.03 | PID action direction |   | Default          | 0 |
|       | Setting range        | 0 | Positive effect  |   |
|       |                      | 1 | Negative effects |   |

0: Forward action

When the feedback value is smaller than the PID setting, the AC drive's output frequency rises. For example, the winding tension control requires forward PID action.

1: Reverse action

When the feedback value is smaller than the PID setting, the AC drive's output frequency reduces. For example, the unwinding tension control requires reverse PID action.

Note that this function is influenced by the DI function 35 "Reverse PID action direction".

|       |                            |           |      |
|-------|----------------------------|-----------|------|
| 11.04 | PID setting feedback range | Default   | 1000 |
|       | Setting range              | 0 ~ 65535 |      |

This parameter is a non-dimensional unit. It is used for PID setting display (00.15) and PID feedback display (00.16). Relative value 100% of PID setting feedback corresponds to the value of 11.04. If 11.04 is set to 2000 and PID setting is 100.0%, the PID setting display (00.15) is 2000.PID

|       |                       |                |        |
|-------|-----------------------|----------------|--------|
| 11.05 | Proportional gain Kp1 | Default        | 20.0   |
|       | Setting range         | 0.0 ~ 100.0    |        |
| 11.06 | Integral time Ti1     | Default        | 2.00s  |
|       | Setting range         | 0.01s ~ 10.00s |        |
| 11.07 | Differential timeTd1  | Default        | 0.000s |
|       | Setting range         | 0.00 ~ 10.000  |        |

- 11.05 (Proportional gain Kp1)

It decides the regulating intensity of the PID regulator. The higher the Kp1 is, the larger the regulating intensity is. The value 100.0 indicates when the deviation between PID feedback and PID setting is 100.0%, the adjustment amplitude of the PID regulator on the output frequency reference is the maximum frequency.

- 11.06 (Integral time Ti1)

It decides the integral regulating intensity. The shorter the integral time is, the larger the regulating intensity is. When the deviation between PID feedback and PID setting is 100.0%, the integral regulator performs continuous adjustment for the time set in 11.06. Then the adjustment amplitude reaches the maximum frequency.

- 11.07 (Differential time Td1)

It decides the regulating intensity of the PID regulator on the deviation change. The longer the differential time is, the larger the regulating intensity is. Differential time is the time within which the feedback value change reaches 100.0%, and then the adjustment amplitude reaches the maximum frequency.

|       |   |                     |        |
|-------|---|---------------------|--------|
| 11.08 | Cut-off frequency of PID reverse rotation | Default             | 2.00Hz |
|       | Setting range                             | 0.00 ~Max frequency |        |

In some cases, only when the PID output frequency is negative (that is, the inverter is reversed), can the PID control the given amount and the feedback amount to the same state, but too high reverse frequency is not allowed in some occasions, 11.08 is used to determine the upper limit of the reverse frequency.

When the frequency source is PID, the upper and lower limits and the range of frequency output:

For example: frequency source is pure PID or main + PID

1) The inversion cut-off frequency is 0 or the inversion is prohibited (that is, any of the following three)

(1) 11.08=0, 09.13=0;

(2) 11.08=0, 09.13=1;

(3) 11.08=0, 09.13=1

Output upper limit: upper limit frequency

Output lower limit: lower limit frequency

Output range: lower limit frequency ~ upper limit frequency (ie 01.14 ~ 01.12)

2) Inversion cut-off frequency is not 0 and inversion is not prohibited (ie 11.08=0, 09.13=0)

Output upper limit: upper limit frequency

Output lower limit: Invert cutoff frequency

Output range: reverse cutoff frequency ~ upper limit frequency

|       |                     |               |      |
|-------|---------------------|---------------|------|
| 11.09 | PID deviation limit | Default       | 0.0% |
|       | Setting range       | 0. 0% ~100.0% |      |

If the deviation between PID feedback and PID setting is smaller than the value of 11.09, PID control stops. The small deviation between PID feedback and PID setting will make the output frequency stabilize, effective for some closed-loop control applications.

|       |                     |                 |       |
|-------|---------------------|-----------------|-------|
| 11.10 | PID deviation limit | Default         | 0.10% |
|       | Setting range       | 0. 00% ~100.00% |       |

It is used to set the PID differential output range. In PID control, the differential operation may easily cause system oscillation. Thus, the PID differential regulation is restricted to a small range.

|       |                         |                |       |
|-------|-------------------------|----------------|-------|
| 11.11 | PID setting change time | Default        | 0.00s |
|       | Setting range           | 0.00s ~650.00s |       |

The PID setting change time indicates the time required for PID setting changing from 0.0% to 100.0%.

The PID setting changes linearly according to the change time, reducing the impact caused by sudden setting change on the system.

|       |                          |                |       |
|-------|--------------------------|----------------|-------|
| 11.12 | PID feedback filter time | Default        | 0.00s |
|       | Setting range            | 0.00s ~ 60.00s |       |
| 11.13 | PID output filter time   | Default        | 0.00s |
|       | Setting range            | 0.00s ~ 60.00s |       |

11.12 is used to filter the PID feedback, helping to reduce interference on the feedback but slowing the response of the process closed-loop system.

11.13 is used to filter the PID output frequency, helping to weaken sudden change of the AC drive output frequency but slowing the response of the process closed-loop system.

|       |                                      |   |   |        |
|-------|--------------------------------------|---|---|--------|
| 11.15 | Proportional gain Kp2                |   | Default                                 | 20.0   |
|       | Setting range                        |   | 0.0 ~ 100.0                             |        |
| 11.16 | Integral time Ti2                    |   | Default                                 | 2.00s  |
|       | Setting range                        |   | 0.01s ~ 10.00s                          |        |
| 11.17 | Differential time Td2                |   | Default                                 | 0.000s |
|       | Setting range                        |   | 0.00 ~ 10.000                           |        |
| 11.18 | PID parameter switchover condition   |   | Default                                 | 0      |
|       | Setting range                        | 0 | No switchover                           |        |
|       |                                      | 1 | Switchover via DI                       |        |
|       |                                      | 2 | Automatic switchover based on deviation |        |
| 11.19 | PID parameter switchover deviation 1 |   | Default                                 | 20.0%  |
|       | Setting range                        |   | 0.0% ~ 11.20                            |        |
| 11.20 | PID parameter switchover deviation 2 |   | Default                                 | 80.0%  |
|       | Setting range                        |   | 11.19 ~ 100.0%                          |        |

In some applications, PID parameters switchover is required when one group of PID parameters cannot satisfy the requirement of the whole running process.

These parameters are used for switchover between two groups of PID parameters. Regulator parameters 11.15 to 11.17 are set in the same way as 11.05 to 11.07.

The switchover can be implemented either via a DI terminal or automatically implemented based on the deviation.

If you select switchover via a DI terminal, the DI must be allocated with function 43 "PID parameter switchover". If the DI is OFF, group 1 (11.05 to 11.07) is selected. If the DI is ON, group 2 (11.15 to 11.17) is selected.

If you select automatic switchover, when the absolute value of the deviation between PID feedback and PID setting is smaller than the value of 11.19, group 1 is selected. When the absolute value of the deviation between PID feedback and PID setting is higher than the value of 11.20, group 2 is selected. When the deviation is between 11.19 and 11.20, the PID parameters are the linear interpolated value of the two groups of parameter values.

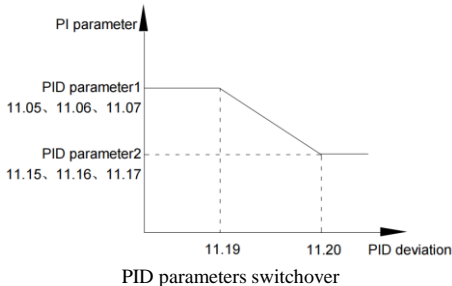

|       |                                |                 |       |
|-------|--------------------------------|-----------------|-------|
| 11.21 | PID initial value              | Default         | 0.0%  |
|       | Setting range                  | 0.0% ~ 100.0%   |       |
| 11.22 | PID initial value holding time | Default         | 0.00s |
|       | Setting range                  | 0.00s ~ 650.00s |       |

When the inverter starts, the PID output is fixed at the PID initial value of 11.21, and the PID starts the closed-loop adjustment operation after the PID initial value hold time of 11.22. Figure 6-36 is a functional schematic diagram of PID initial value.

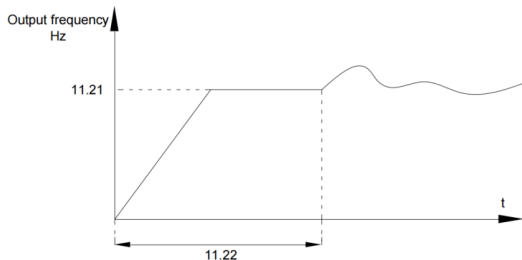

PID initial value function

|       |                         |              |  |    |
|-------|-------------------------|--------------|--|----|
| 11.25 | PID integral property   |              | Default  | 00 |
|       | Setting range           | Unit's digit | Integral separated   |    |
|       |                         | 0            | Invalid  |    |
|       |                         | 1            | Valid  |    |
|       |                         | Ten's digit  | Whether to stop integral operation when the output reaches the limit |    |
|       |                         | 0            | Continue integral operation  |    |
| 1     | Stop integral operation |              |  |    |

- Integral separated

If it is set to valid, , the PID integral operation stops when the DI allocated with function 38 "PID integral pause" is ON In this case, only proportional and differential operations take effect.

If it is set to invalid, integral separated remains invalid no matter whether the DI allocated with function 38 "PID integral pause" is ON or not.

- Whether to stop integral operation when the output reaches the limit

If "Stop integral operation" is selected, the PID integral operation stops, which may help to reduce the PID overshoot.

|       |                                      |                                  |      |
|-------|--------------------------------------|----------------------------------|------|
| 11.26 | Detection value of PID feedback loss | Default                          | 0.0% |
|       | Setting range                        | 0.0%: Not judging feedback loss; |      |
| 11.27 | Detection time of PID feedback loss  | Default                          | 0.0s |
|       | Setting range                        | 0.0s ~ 20.0s                     |      |

These parameters are used to judge whether PID feedback is lost.

If the PID feedback is smaller than the value of 11.26 and the lasting time exceeds the value of 11.27, the AC drive reports Err31 and acts according to the selected fault protection action.

|       |                       |   |                          |   |
|-------|-----------------------|---|--------------------------|---|
| 11.28 | PID operation at stop |   | Default                  | 0 |
|       | Setting range         | 0 | No PID operation at stop |   |
|       |                       | 1 | PID operation at stop    |   |

It is used to select whether to continue PID operation in the state of stop. Generally, the PID operation stops when the AC drive stops.

## Group 12: Swing Frequency, Fixed Length and Count

The swing frequency function is applied to the textile and chemical fiber fields and the applications where traversing and winding functions are required.

The swing frequency function indicates that the output frequency of the AC drive swings up and down with the set frequency as the center. The trace of running frequency at the time axis is shown in the following figure.

The swing amplitude is set in 12.00 and 12.01. When 12.01 is set to 0, the swing amplitude is 0 and the swing frequency does not take effect.

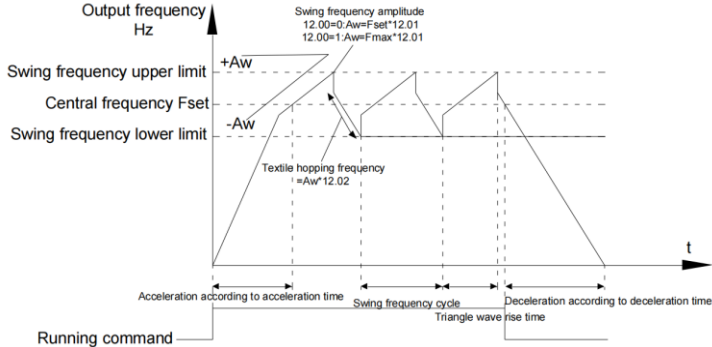

Schematic diagram of swing frequency operation

|       |                              |   |                                   |   |
|-------|------------------------------|---|-----------------------------------|---|
| 12.00 | Swing frequency setting mode |   | Default                           | 0 |
|       | Setting range                | 0 | Relative to the central frequency |   |
|       |                              | 1 | Relative to the maximum frequency |   |

This parameter is used to select the base value of the swing amplitude.

- 0: Relative to the central frequency (01.07 frequency source selection)

It is variable swing amplitude system. The swing amplitude varies with the central frequency (set frequency).

- 1: Relative to the maximum frequency (01.10 maximum output frequency)

It is fixed swing amplitude system. The swing amplitude is fixed.

|       |                           |               |      |
|-------|---------------------------|---------------|------|
| 12.01 | Swing frequency amplitude | Default       | 0.0% |
|       | Setting range             | 0.0% ~ 100.0% |      |
| 12.02 | Jump frequency amplitude  | Default       | 0.0% |
|       | Setting range             | 0.0% ~ 50.0%  |      |

This parameter is used to determine the swing amplitude and jump frequency amplitude.

The swing frequency is limited by the frequency upper limit and frequency lower limit.

- If relative to the central frequency (12.00 = 0), the actual swing amplitude AW is the calculation result of 01.07 (Frequency source selection) multiplied by 12.01.
- If relative to the maximum frequency (12.00 = 1), the actual swing amplitude AW is the calculation result of 01.10 (Maximum frequency) multiplied by 12.01.

Jump frequency = Swing amplitude AW x 12.02 (Jump frequency amplitude).

- If relative to the central frequency (12.00 = 0), the jump frequency is a variable value.
- If relative to the maximum frequency (12.00 = 1), the jump frequency is a fixed value.

The swing frequency is limited by the frequency upper limit and frequency lower limit.

|       |   |                |       |
|-------|---|----------------|-------|
| 12.03 | Swing frequency cycle                   | Default        | 10.0s |
|       | Setting range                           | 0.0s ~ 3000.0s |       |
| 12.04 | Triangular wave rising time coefficient | Default        | 50.0% |
|       | Setting range                           | 0.0% ~ 100.0%  |       |

12.03 specifies the time of a complete swing frequency cycle.

12.04 specifies the time percentage of triangular wave rising time to 12.03 (Swing frequency cycle).

- Triangular wave rising time = 12.03 (Swing frequency cycle) x 12.04 (Triangular wave rising time coefficient, unit: s)
- Triangular wave falling time = 12.03 (Swing frequency cycle) x (1 - 12.04 Triangular wave rising time coefficient, unit: s)

|       |                |              |       |
|-------|----------------|--------------|-------|
| 12.05 | Setting Length | Default      | 1000m |
|       | Setting range  | 0m ~ 65535m  |       |
| 12.06 | Actual Length  | Default      | 0m    |
|       | Setting range  | 0m ~ 65535m  |       |
| 12.07 | Pulse/meter    | Default      | 100.0 |
|       | Setting range  | 0.1 ~ 6553.5 |       |

The preceding parameters are used for fixed length control.

The length information is collected by DI terminals. 12.06 (Actual length) is calculated by dividing the number of pulses collected by the DI terminal by 12.07 (Number of pulses each meter).

When the actual length 12.06 exceeds the set length in 12.05, the DO terminal allocated with function 10 (Length reached) becomes ON.

During the fixed length control, the length reset operation can be performed via the DI terminal allocated with function 28. For details, see the descriptions of P4-00 to P4-09.

Allocate corresponding DI terminal with function 27 (Length count input) in applications. If the pulse frequency is high, DI5 must be used.

|       |                        |           |      |
|-------|------------------------|-----------|------|
| 12.08 | Set count value        | Default   | 1000 |
|       | Setting range          | 1 ~ 65535 |      |
| 12.09 | Designated count value | Default   | 1000 |
|       | Setting range          | 1 ~ 65535 |      |

The count value needs to be collected by DI terminal. Allocate the corresponding DI terminal with function 25 (Counter input) in applications. If the pulse frequency is high, DI5 must be used.

When the count value reaches the set count value (12.08), the DO terminal allocated with function 8 (Set count value reached) becomes ON. Then the counter stops counting.

When the counting value reaches the designated counting value (12.09), the DO terminal allocated with function 9 (Designated count value reached) becomes ON. Then the counter continues to count until the set count value is reached.

12.09 should be equal to or smaller than 12.08.

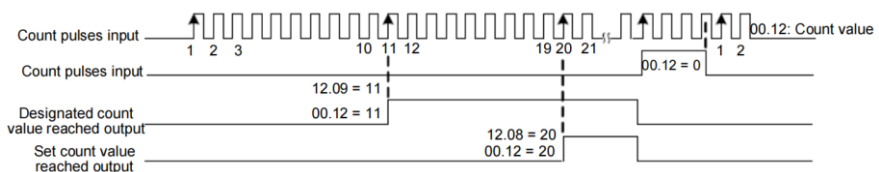

Reaching the set count value and designated count value

### Group13 Multi-stage speed command and simple PLC function

The multi-stage speed command of DSI-100 has more functions than the usual multi-stage speed. In addition to realizing the multi-stage speed function, it can also be used as a voltage source for VF separation and a given source for process PID. For this reason, the dimensions of multi-segment instructions are relative.

The simple PLC function is different from the user programmable function of DSI-100. Simple PLC can only complete the simple combined operation of multi-segment instructions.

|       |                    |                  |       |
|-------|--------------------|------------------|-------|
| 13.00 | Multi-reference 0  | Default          | 0.0%  |
|       | Setting range      | -100.0% ~ 100.0% |       |
| 13.01 | Multi-reference 1  | Default          | 0.0%  |
|       | Setting range      | -100.0% ~ 100.0% |       |
| 13.02 | Multi-reference 2  | Default          | 0.0%  |
|       | Setting range      | -100.0% ~ 100.0% |       |
| 13.03 | Multi-reference 3  | Default          | 0.0%  |
|       | Setting range      | -100.0% ~ 100.0% |       |
| 13.04 | Multi-reference 4  | Default          | 0.0%  |
|       | Setting range      | -100.0% ~ 100.0% |       |
| 13.05 | Multi-reference 5  | Default          | 0.0%  |
|       | Setting range      | -100.0% ~ 100.0% |       |
| 13.06 | Multi-reference 6  | Default          | 0.0%  |
|       | Setting range      | -100.0% ~ 100.0% |       |
| 13.07 | Multi-reference 7  | Default          | 0.0%  |
|       | Setting range      | -100.0% ~ 100.0% |       |
| 13.08 | Multi-reference 8  | Default          | 0.0%  |
|       | Setting range      | -100.0% ~ 100.0% |       |
| 13.09 | Multi-reference 9  | Default          | 0.0%  |
|       | Setting range      | -100.0% ~ 100.0% |       |
| 13.10 | Multi-reference 10 | Default          | 0.0Hz |
|       | Setting range      | -100.0% ~ 100.0% |       |
| 13.11 | Multi-reference 11 | Default          | 0.0%  |
|       | Setting range      | -100.0% ~ 100.0% |       |
| 13.12 | Multi-reference 12 | Default          | 0.0%  |
|       | Setting range      | -100.0% ~ 100.0% |       |
| 13.13 | Multi-reference 13 | Default          | 0.0%  |
|       | Setting range      | -100.0% ~ 100.0% |       |
| 13.14 | Multi-reference 14 | Default          | 0.0%  |
|       | Setting range      | -100.0% ~ 100.0% |       |
| 13.15 | Multi-reference 15 | Default          | 0.0%  |
|       | Setting range      | -100.0% ~ 100.0% |       |

Multi-reference can be the setting source of frequency, V/F separated voltage and process PID. The multi-reference is relative value and ranges from -100.0% to 100.0%.

As frequency source, it is a percentage relative to the maximum frequency.

As V/F separated voltage source, it is a percentage relative to the rated motor voltage. As process PID

setting source, it does not require conversion.

Multi-reference can be switched over based on different states of DI terminals. For details, see the descriptions of group 05.

|       |                         |   |   |   |
|-------|-------------------------|---|---|---|
| 13.16 | Simple PLC running mode |   | Default                                   | 0 |
|       | Setting range           | 0 | Stop after the AC drive runs one cycle    |   |
|       |                         | 1 | Keep final values after the AC drive runs |   |
|       |                         | 2 | Repeat after the AC drive runs one cycle  |   |

The AC drive stops after running one cycle, and will not start up until receiving another command.

- 1: Keep final values after the AC drive runs one cycle

The AC drive keeps the final running frequency and direction after running one cycle.

- 2: Repeat after the AC drive runs one cycle

The AC drive automatically starts another cycle after running one cycle, and will not stop until receiving the stop command.

Simple PLC can be either the frequency source or V/F separated voltage source.

When simple PLC is used as the frequency source, whether parameter values of 13.00 to 13.15 are positive or negative determines the running direction. If the parameter values are negative, it indicates that the AC drive runs in reverse direction.

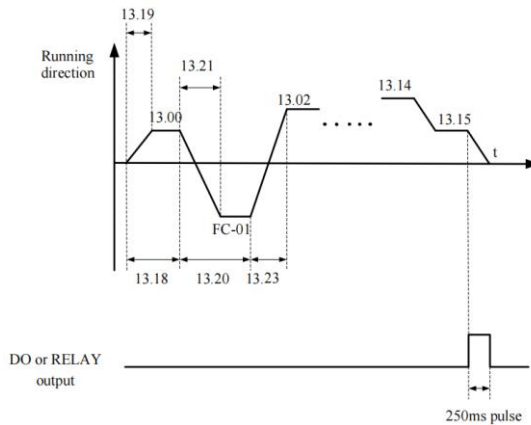

Simple PLC when used as frequency source

|       |                                |              |                              |    |
|-------|--------------------------------|--------------|------------------------------|----|
| 13.17 | Simple PLC retentive selection |              | Default                      | 00 |
|       | Setting range                  | Unit's digit | Retentive upon power failure |    |
|       |                                | 0            | No                           |    |
|       |                                | 1            | Yes                          |    |
|       |                                | Ten's digit  | Retentive upon stop          |    |
|       |                                | 0            | No                           |    |
| 1     |                                | Yes          |                              |    |

PLC retentive upon power failure indicates that the AC drive memorizes the PLC running moment and running frequency before power failure and will continue to run from the memorized moment after it is powered on again. If the unit's digit is set to 0, the AC drive restarts the PLC process after it is powered on again.

PLC retentive upon stop indicates that the AC drive records the PLC running moment and running frequency upon stop and will continue to run from the recorded moment after it starts up again. If the ten's digit is set to 0, the AC drive restarts the PLC process after it starts up again.



|       |  |                      |         |
|-------|--|----------------------|---------|
| 13.18 | Running time of simple PLC reference 0                   | Default              | 0.0s(h) |
|       | Setting range  | 0.0s(h) ~ 6553.5s(h) |         |
| 13.19 | Acceleration/deceleration time of simple PLC reference 0 | Default              | 0       |
|       | Setting range  | 0 ~ 3                |         |
| 13.20 | Running time of simple PLC reference 1                   | Default              | 0.0s(h) |
|       | Setting range  | 0.0s(h) ~ 6553.5s(h) |         |
| 13.21 | Acceleration/deceleration time of simple PLC reference 1 | Default              | 0       |
|       | Setting range  | 0 ~ 3                |         |
| 13.22 | Running time of simple PLC reference 2                   | Default              | 0.0s(h) |
|       | Setting range  | 0.0s(h) ~ 6553.5s(h) |         |
| 13.23 | Acceleration/deceleration time of simple PLC reference 2 | Default              | 0       |
|       | Setting range  | 0 ~ 3                |         |
| 13.24 | Running time of simple PLC reference 3                   | Default              | 0.0s(h) |
|       | Setting range  | 0.0s(h) ~ 6553.5s(h) |         |
| 13.25 | Acceleration/deceleration time of simple PLC reference 3 | Default              | 0       |
|       | Setting range  | 0 ~ 3                |         |
| 13.26 | Running time of simple PLC reference 4                   | Default              | 0.0s(h) |
|       | Setting range  | 0.0s(h) ~ 6553.5s(h) |         |
| 13.27 | Acceleration/deceleration time of simple PLC reference 4 | Default              | 0       |
|       | Setting range  | 0 ~ 3                |         |
| 13.28 | Running time of simple PLC reference 5                   | Default              | 0.0s(h) |
|       | Setting range  | 0.0s(h) ~ 6553.5s(h) |         |
| 13.29 | Acceleration/deceleration time of simple PLC reference 5 | Default              | 0       |
|       | Setting range  | 0 ~ 3                |         |
| 13.30 | Running time of simple PLC reference 6                   | Default              | 0.0s(h) |
|       | Setting range  | 0.0s(h) ~ 6553.5s(h) |         |
| 13.31 | Acceleration/deceleration time of simple PLC reference 6 | Default              | 0       |
|       | Setting range  | 0 ~ 3                |         |
| 13.32 | Running time of simple PLC reference 7                   | Default              | 0.0s(h) |
|       | Setting range  | 0.0s(h) ~ 6553.5s(h) |         |
| 13.33 | Acceleration/deceleration time of simple PLC reference 7 | Default              | 0       |
|       | Setting range  | 0 ~ 3                |         |
| 13.34 | Running time of simple PLC reference 8                   | Default              | 0.0s(h) |
|       | Setting range  | 0.0s(h) ~ 6553.5s(h) |         |
| 13.35 | Acceleration/deceleration time of simple PLC reference 8 | Default              | 0       |
|       | Setting range  | 0 ~ 3                |         |
| 13.36 | Running time of simple PLC reference 9                   | Default              | 0.0s(h) |
|       | Setting range  | 0.0s(h) ~ 6553.5s(h) |         |
| 13.37 | Acceleration/deceleration time of simple PLC reference 9 | Default              | 0       |
|       | Setting range  | 0 ~ 3                |         |

|       |   |                       |            |
|-------|---|-----------------------|------------|
| 13.38 | Running time of simple PLC reference 10                   | Default               | 0.0s(h)    |
|       | Setting range   | 0.0 s(h) ~ 6553.5s(h) |            |
| 13.39 | Acceleration/deceleration time of simple PLC reference 10 | Default               | 0          |
|       | Setting range   | 0 ~ 3                 |            |
| 13.40 | Running time of simple PLC reference 11                   | Default               | 0.0s(h)    |
|       | Setting range   | 0.0s(h) ~ 6553.5s(h)  |            |
| 13.41 | Acceleration/deceleration time of simple PLC reference 11 | Default               | 0          |
|       | Setting range   | 0 ~ 3                 |            |
| 13.42 | Running time of simple PLC reference 12                   | Default               | 0.0s(h)    |
|       | Setting range   | 0.0s(h) ~ 6553.5s(h)  |            |
| 13.43 | Acceleration/deceleration time of simple PLC reference 12 | Default               | 0          |
|       | Setting range   | 0 ~ 3                 |            |
| 13.44 | Running time of simple PLC reference 13                   | Default               | 0.0s(h)    |
|       | Setting range   | 0.0s(h) ~ 6553.5s(h)  |            |
| 13.45 | Acceleration/deceleration time of simple PLC reference 13 | Default               | 0          |
|       | Setting range   | 0 ~ 3                 |            |
| 13.46 | Running time of simple PLC reference 14                   | Default               | 0.0s(h)    |
|       | Setting range   | 0.0s(h) ~ 6553.5s(h)  |            |
| 13.47 | Acceleration/deceleration time of simple PLC reference 14 | Default               | 0          |
|       | Setting range   | 0 ~ 3                 |            |
| 13.48 | Running time of simple PLC reference 15                   | Default               | 0.0s(h)    |
|       | Setting range   | 0.0s(h) ~ 6553.5s(h)  |            |
| 13.49 | Acceleration/deceleration time of simple PLC reference 15 | Default               | 0          |
|       | Setting range   | 0 ~ 3                 |            |
| 13.50 | Time unit of simple PLC running                           | Default               | 0          |
|       | Setting range   | 0                     | S (Second) |
|       |   | 1                     | H (Hours)  |

|       |               |   |  |   |
|-------|---------------|---|--|---|
| 13.51 | Reference     | 0 | Default  | 0 |
|       | Setting range | 0 | Set by 13.00   |   |
|       |               | 1 | AI1  |   |
|       |               | 2 | AI2  |   |
|       |               | 3 | AI3 (Keyboard Potentiometer)                                   |   |
|       |               | 4 | PULSE  |   |
|       |               | 5 | PID  |   |
|       |               | 6 | Set by preset frequency (01.08), modified via terminal UP/DOWN |   |

It determines the setting channel of reference 0. You can perform convenient switchover between the setting channels. When multi-reference or simple PLC is used as frequency source, the switchover between two frequency sources can be realized easily.

## Group14 Communication parameters

Please refer to "DSI-100 Communication Protocol"

### Group 17 User Password

|       |                 |           |   |
|-------|-----------------|-----------|---|
| 17.00 | User's password | Default   | 0 |
|       | Setting range   | 0 ~ 65535 |   |

If it is set to any non-zero number, the password protection function is enabled. After a password has been set and taken effect, you must enter the correct password in order to enter the menu. If the entered password is incorrect you cannot view or modify parameters.

If 17.00 is set to 00000, the previously set user password is cleared, and the password protection function is disabled.

|       |                 |         |  |
|-------|-----------------|---------|--|
| 17.01 | Restore default | Default | 0  |
|       | Setting range   | 0       | No option settings                               |
|       |                 | 1       | Restore factory settings except motor parameters |
|       |                 | 2       | Clear records                                    |

1: Restore the factory setting, excluding motor parameters

After setting 17.01 to 1, most of the functional parameters of the inverter are restored to the factory default parameters, but the motor parameters, frequency command decimal point (01.22), fault record information, cumulative running time (08.09), cumulative power-on time (08.13), cumulative Power consumption (08.14) is not restored.

2: Clear record information

Clear the inverter fault record information, cumulative running time (08.09), cumulative power-on time (08.13), and cumulative power consumption (08.14).

|       |   |              |   |    |
|-------|---|--------------|---|----|
| 17.02 | AC drive parameter display property       |              | Default                                   | 11 |
|       | Setting range                             | Unit's digit | Group U display selection                 |    |
|       |   | 0            | No display                                |    |
|       |   | 1            | Display                                   |    |
|       |   | Ten's digit  | Group A display selection                 |    |
|       |   | 0            | No display                                |    |
| 1     |   | Display      |   |    |
| 17.03 | Individualized parameter display property |              | Default                                   | 00 |
|       | Setting range                             | Unit's digit | User-defined parameter display selection  |    |
|       |   | 0            | No display                                |    |
|       |   | 1            | Display                                   |    |
|       |   | Ten's digit  | User-modified parameter display selection |    |
|       |   | 0            | No display                                |    |
| 1     |   | Display      |   |    |

The setting of parameter display mode aims to facilitate you to view different types of parameters based on actual requirements. The DSI-100 provides the following three parameter display modes.

| Parameter Name                  | Description  |
|---------------------------------|--|
| AC drive parameter display      | Display function codes of the AC drive in sequence of 01 to 16, 18 to 33 and 00 Group. |
| User-defined parameter display  | Display a maximum of 32 user-defined parameters included in group 15.                  |
| User-modified parameter display | Display the parameters that are modified.  |

If one digit of 17.03 is set to 1, you can switch over to different parameter display modes by pressing key QUICK. By default, the AC drive parameter display mode is used.

The display codes of different parameter types are shown in the following table.

| Parameter Display Mode  | Display |
|-------------------------|---------|
| AC drive parameter      | -BASE   |
| User-defined parameter  | -USER   |
| User-modified parameter | --[- -  |

The DSI-100 provides display of two types of individualized parameters: user-defined parameters and user-modified parameters.

- You-defined parameters are included in group PE. You can add a maximum of 32 parameters, convenient for commissioning.

In user-defined parameter mode, symbol "u" is added before the function code. For example, 02.00 is displayed as u02.00.

- You-modified parameters are grouped together, convenient for on-site troubleshooting.

In you-modified parameter mode, symbol "c" is added before the function code. For example, 02.00 is displayed as c02.00.

|       |                                 |         |                |
|-------|---------------------------------|---------|----------------|
| 17.04 | Parameter modification property | Default | 0              |
|       | Setting range                   | 0       | Modifiable     |
|       |                                 | 1       | Not modifiable |

It is used to set whether the parameters are modifiable to avoid mal-function. If it is set to 0, all parameters are modifiable. If it is set to 1, all parameters can only be viewed.

## Group18~22 Reserved

## Group 23 Control optimization parameters

|       |                      |                       |     |
|-------|----------------------|-----------------------|-----|
| 23.00 | DPWM switching upper | Default               | 8Hz |
|       | Setting range        | 5.00Hz~Max. frequency |     |

This parameter is valid only for V/F control.

It is used to determine the wave modulation mode in V/F control of asynchronous motor.

If the frequency is lower than the value of this parameter, the waveform is 7-segment continuous modulation. If the frequency is higher than the value of this parameter, the waveform is 5-segment intermittent modulation.

The 7-segment continuous modulation causes more loss to switches of the AC drive but smaller current ripple.

The 5-segment intermittent modulation causes less loss to switches of the AC drive but larger current ripple.

This may lead to motor running instability at high frequency. Do not modify this parameter generally.

For instability of V/F control, refer to parameter 04.11. For loss to AC drive and temperature rise, refer to parameter 01.15.

|       |                     |   |                         |   |
|-------|---------------------|---|-------------------------|---|
| 23.01 | PWM modulation mode |   | Default                 | 0 |
|       | Setting range       | 0 | Asynchronous modulation |   |
|       |                     | 1 | Synchronous modulation  |   |

This parameter is valid only for V/F control.

Synchronous modulation indicates that the carrier frequency varies linearly with the change of the output frequency, ensuring that the ratio of carrier frequency to output frequency remains unchanged. Synchronous modulation is generally used at high output frequency, which helps improve the output voltage quality.

At low output frequency (100 Hz or lower), synchronous modulation is not required. This is because asynchronous modulation is preferred when the ratio of carrier frequency to output frequency is high. Synchronous modulation takes effect only when the running frequency is higher than 85 Hz.

If the frequency is lower than 85 Hz, asynchronous modulation is always used.

|       |                             |   |                     |   |
|-------|-----------------------------|---|---------------------|---|
| 23.02 | Dead-zone compensation mode |   | Default             | 1 |
|       | Setting range               | 0 | No compensation     |   |
|       |                             | 1 | Compensation mode 1 |   |

Generally, you need not modify this parameter. Try to use a different compensation mode only when there is special requirement on the output voltage waveform quality or oscillation occurs on the motor. For high power AC drive, compensation mode 2 is recommended.

|       |                  |      |                                    |   |
|-------|------------------|------|------------------------------------|---|
| 23.03 | Random PWM depth |      | Default                            | 0 |
|       | Setting range    | 0    | Random PWM invalid                 |   |
|       |                  | 1~10 | PWM carrier frequency random depth |   |

The setting of random PWM depth can make the shrill motor noise softer and reduce the electromagnetic interference. If this parameter is set to 0, random PWM is invalid.

|       |                               |   |          |   |
|-------|-------------------------------|---|----------|---|
| 23.04 | Rapid current-limiting enable |   | Default  | 1 |
|       | Setting range                 | 0 | Disabled |   |
|       |                               | 1 | Enabled  |   |

The rapid current limit function can reduce the AC drive's overcurrent faults at maximum, guaranteeing uninterrupted running of the AC drive.

However, long-time rapid current limit may cause the AC drive to overheat, which is not allowed. In this case, the AC drive will report Err40, indicating the AC drive is overloaded and needs to stop.

|       |                                |         |   |
|-------|--------------------------------|---------|---|
| 23.05 | Current detection compensation | Default | 5 |
|       | Setting range                  | 0~100   |   |

It is used to set the AC drive current detection compensation. Too large value may lead to deterioration of control performance. Do not modify it generally

|       |                           |                |                |
|-------|---------------------------|----------------|----------------|
| 23.06 | Under-voltage point setup | Default        | Model depended |
|       | Setting range             | 200.0V~2000.0V |                |

It is used to set the voltage value of the inverter undervoltage fault Err09 fault. The factory default value is related to the model.

| Voltage Class      | Nominal Value of Undervoltage threshold |
|--------------------|---|
| Single-phase 220 V | 200 V                                   |
| Three-phase 220 V  | 200 V                                   |
| Three-phase 380 V  | 350 V                                   |
| Three-phase 480 V  | 450 V                                   |
| Three-phase 690 V  | 650 V                                   |

|       |                          |                |                |
|-------|--------------------------|----------------|----------------|
| 23.09 | Over-voltage point setup | Default        | Model depended |
|       | Setting range            | 200.0V~2500.0V |                |

It is used to set the overvoltage threshold of the AC drive. The default values of different voltage classes are listed in the following table.

| Voltage Class      | Default Overvoltage Threshold |
|--------------------|-------------------------------|
| Single-phase 220 V | 400.0 V                       |
| Three-phase 220 V  | 400.0 V                       |
| Three-phase 380 V  | 810.0 V                       |
| Three-phase 480 V  | 890.0 V                       |
| Three-phase 690 V  | 1300.0 V                      |

Overvoltage thresholds for different voltage classes

Note: The default value is also the upper limit of the inverter's internal overvoltage protection. This parameter setting takes effect only when the set value of 23.09 is less than the ex-factory value of each voltage level. When it is higher than the factory value, the factory value shall prevail.

# Chapter 7 Fault Display and settlement

## 7.1 Guidance on the adjustment of the inverter before commissioning

### 1) Drive in Open-loop Vector Control ( 01.01=0 )

The AC drive implements control of the motor speed and torque without an encoder for speed feedback. In this control mode, motor auto-tuning is required to obtain the motor related

| Error  | Solution  |
|--|---|
| Overload or Over current detected during motor start                     | <ul style="list-style-type: none"> <li>◆ Set motor parameters ( 02.01~02.05 ) according to motor nameplate.</li> <li>◆ Select a proper motor auto-tuning mode by setting 02.37 and perform motor auto-tuning. If possible, select dynamic auto-tuning</li> </ul>  |
| Poor torque or speed response and motor oscillation at speeds below 5 Hz | <ul style="list-style-type: none"> <li>◆ 1. If motor torque and speed response are too slow, increase the setting of 03.00 (speed loop proportional gain 1) by 10 gradually or decrease the setting of 03.01 (speed loop integral time 1) by 0.05 gradually.</li> <li>◆ 2. If motor oscillation occurs, decrease the setting of 03.00 and 03.01.</li> </ul> |
| Poor torque or speed response and motor oscillation at speeds above 5 Hz | <ul style="list-style-type: none"> <li>◆ 1. If motor torque and speed response are too slow, increase the setting of 03.03 (speed loop proportional gain 2) by 10 gradually or decrease the setting of 03.04 (speed loop integral time 4) by 0.05 gradually.</li> <li>◆ 2. If motor oscillation occurs, decrease the setting of 03.03 and 03.04.</li> </ul> |
| Low speed accuracy   | <ul style="list-style-type: none"> <li>◆ If speed error when motor runs with load is large, increase the setting of 03.06 (vector control slip compensation gain) by 10% gradually.</li> </ul>  |
| Obvious speed fluctuation  | <ul style="list-style-type: none"> <li>◆ If motor speed fluctuation is large, increase the setting of 03.07 (SVC torque filter time) by 0.001s gradually.</li> </ul>  |
| Too loud motor noise   | <ul style="list-style-type: none"> <li>◆ Increase the setting of 01.15 (carrier frequency) by 1.0 kHz gradually. Note that increase in carrier frequency will result in an increase in the leakage current of the motor.</li> </ul>   |
| Insufficiency motor torque   | <ul style="list-style-type: none"> <li>◆ Check whether torque upper limit is small. If yes, please Increase the setting of 03.10 (digital setting of torque upper limit in speed control mode) in the speed control mode ; Increase the torque reference in the torque control mode.</li> </ul>   |
| Obvious speed fluctuation  | <ul style="list-style-type: none"> <li>◆ If motor speed fluctuation is large, increase the setting of 03.07 (SVC torque filter time) by 0.001s gradually.</li> </ul>  |
| Too loud motor noise   | <ul style="list-style-type: none"> <li>◆ Increase the setting of 01.15 (carrier frequency) by 1.0 kHz gradually. Note that increase in carrier frequency will result in an increase in the leakage current of the motor.</li> </ul>   |

|                           |  |
|---------------------------|--|
| Insufficient motor torque | <p>◆ Check whether torque upper limit is small. If yes, please:<br/>Increase the setting of 03.10 (digital setting of torque upper limit in speed control mode in the speed control mode).</p> |
|---------------------------|--|

2 ) Drive in V/F Control (01.01=2 factory default)

It is applicable to application without an encoder for speed feedback. You need to set rated motor voltage and rated motor frequency correctly.

| Error  | Solution   |
|--|--|
| Motor oscillation during running   | 1. Increase the setting of 04.11 (V/F oscillation suppression gain) by 10 gradually. The permissible maximum setting here is 100.  |
| Over current during start  | 1. Decrease the setting of 04.01 (torque boost) by 0.5% gradually.   |
| Too loud motor noise   | 1. Increase the setting of 01.15 (carrier frequency) by 1.0 kHz gradually. Note that increase in carrier frequency will result in an increase in the leakage current of the motor.   |
| Very large current during running  | 1. Set rated motor voltage (02.02) and rated motor frequency (02.04) correctly.<br>2. Decrease the setting of 04.01 (torque boost) by 0.5% gradually.  |
| Over voltage detected when heavy load is suddenly removed or during deceleration | 1. Ensure that 04.23 (voltage limit selection) is set to 1 (enabled). Increase the setting of 04.24/04.25 (frequency gain/voltage gain for voltage limit) by 10 gradually. The permissible maximum setting here is 100.<br>2. Decrease the setting of 04.22 (voltage limit 770v) by 10 V gradually. The permissible minimum setting here is 700 V. |
| Over current detected when heavy load is suddenly added or during acceleration   | 1. Increase the setting of 04.20 (04.20 factory default set 20) by 10 gradually. The permissible maximum setting here is 100.<br>2. Decrease the setting of 04.18 (04.18 factory default is 150%) by 10% gradually.<br>The permissible minimum setting here is 50%.  |



## 7.2 Fault Display

When a fault occurs during running, The operation panel displays the fault code such as shown in the following figure.

| Fault                            | Displ | Fault reason   | Error settlement   |
|----------------------------------|-------|--|--|
| Over current during acceleration | E.oC1 | Ground fault or short circuit exists in the output circuit.      | <ul style="list-style-type: none"> <li>◆ Check whether short-circuit occurs on the motor, motor cable or contactor.</li> </ul>   |
|                                  |       | Control mode is SVC but motor auto-tuning is not performed.      | <ul style="list-style-type: none"> <li>◆ Set motor parameters according to motor nameplate and perform motor auto-tuning.</li> </ul>   |
|                                  |       | Acceleration time is too short.                                  | <ul style="list-style-type: none"> <li>◆ Increase acceleration time.</li> </ul>  |
|                                  |       | The over current stall prevention parameters are set improperly. | <ul style="list-style-type: none"> <li>◆ Ensure that current limit is enabled (04.19 = 1).</li> <li>◆ The setting of current limit level (04.18) is too large. Adjust it between 120% and 150%.</li> <li>◆ The setting of current limit gain (04.20) is too small. Adjust it between 20 and 40.</li> </ul> |
|                                  |       | Customized torque boost or V/F curve is not appropriate.         | <ul style="list-style-type: none"> <li>◆ Adjust the customized torque boost or V/F curve.</li> </ul>   |
|                                  |       | The spinning motor is started.                                   | <ul style="list-style-type: none"> <li>◆ Enable the catching a spinning motor function or start the motor</li> </ul>   |
|                                  |       | The AC drive suffers external interference.                      | <ul style="list-style-type: none"> <li>◆ View historical fault records. If the current value is far from the over current level, find interference source. If external interference does not exist, it is the drive board or hall device problem.</li> </ul>   |
| Over current during deceleration | E.oC2 | Ground fault or short circuit exists in the output circuit.      | <ul style="list-style-type: none"> <li>◆ Check whether short-circuit occurs on the motor, motor cable or contactor.</li> </ul>   |
|                                  |       | Control mode is SVC but motor auto-tuning is not performed.      | <ul style="list-style-type: none"> <li>◆ Set the motor parameters according to the motor nameplate and perform motor auto-tuning.</li> </ul>   |
|                                  |       | Acceleration time is too short.                                  | <ul style="list-style-type: none"> <li>◆ Increase acceleration time.</li> </ul>  |
|                                  |       | The over current stall prevention parameters are set             | <ul style="list-style-type: none"> <li>◆ Ensure that current limit is enabled (04.19 = 1)</li> <li>◆ The setting of current limit level</li> </ul>   |

|                                  |       |  |   |
|----------------------------------|-------|--|---|
|                                  |       | improperly.  | <p>(04.18) is too large. Adjust it between 120% and 150%.</p> <p>◆ The setting of the current limit gain (04.20) is too small. Adjust it between 20 and 40.</p>   |
|                                  |       | Braking unit and braking resistor are not installed.             | ◆ Install braking unit and braking resistor.  |
|                                  |       | The AC drive suffers external interference.                      | ◆ View historical fault records. If the current value is far from the over current level, find interference source. If external interference does not exist, it is the drive board or hall device problem.  |
| Over current at constant speed   | E.oC3 | Ground fault or short circuit exists in                          | ◆ Check whether short-circuit occurs on the motor, motor cable or contactor.  |
|                                  |       | Control mode is SVC but motor auto-tuning is not performed       | ◆ Set motor parameters according to motor nameplate and perform motor auto-tuning.  |
|                                  |       | The over current stall prevention parameters are set improperly. | <p>◆ Ensure that current limit is enabled (04.19).</p> <p>◆ The setting of current limit level (04.18) is too large. Adjust it between 120% and 150%.</p> <p>◆ The setting of current limit gain (04.20) is too small. Adjust it between 20 and 40.</p> |
|                                  |       | The AC drive power class is small.                               | ◆ If output current exceeds rated motor current or rated output current of the AC drive during stable running, replace a drive of larger power class.   |
|                                  |       | The drive suffers external interference.                         | ◆ View historical fault records. If the current value is far from the over current level, find interference source. If external interference does not exist, it is the drive board or hall device   |
|                                  |       |  |   |
| Over voltage during acceleration | E.oU1 | Input voltage is too high.                                       | ◆ Adjust input voltage to normal range.   |
|                                  |       | An external force drives motor during acceleration.              | ◆ Cancel the external force or install a braking resistor.  |

|                                  |       |  |   |
|----------------------------------|-------|--|---|
|                                  |       | The over voltage stall prevention parameters are set improperly. | <ul style="list-style-type: none"> <li>◆ Ensure that the voltage limit function is enabled (04.23 ).</li> <li>◆ The setting of voltage limit (04.22) is too large. Adjust it between 700 V and 770 V.</li> <li>◆ The setting of frequency gain for voltage limit (04.24) is too small. Adjust it between 30 and 50.</li> </ul>  |
|                                  |       | Braking unit and braking resistor are not installed.             | <ul style="list-style-type: none"> <li>◆ Install braking unit and braking resistor.</li> </ul>  |
|                                  |       | Acceleration time is too short.                                  | <ul style="list-style-type: none"> <li>◆ Increase acceleration time.</li> </ul>   |
| Over voltage during deceleration | E.oU2 | The over voltage stall prevention parameters are set improperly. | <ul style="list-style-type: none"> <li>◆ Ensure that the voltage limit function is enabled (04.23 ).</li> <li>◆ The setting of voltage limit (04.22) is too large. Adjust it between 700 V and 770 V.</li> <li>◆ The setting of frequency gain for voltage limit (04.24) is too small. Adjust it between 30 and 50.</li> </ul>  |
|                                  |       | An external force drives motor during deceleration.              | <ul style="list-style-type: none"> <li>◆ Cancel the external force or install braking resistor.</li> </ul>  |
|                                  |       | Deceleration time is too short.                                  | <ul style="list-style-type: none"> <li>◆ Increase deceleration time.</li> </ul>   |
|                                  |       | Braking unit and braking resistor are not installed.             | <ul style="list-style-type: none"> <li>◆ Install braking unit and braking resistor.</li> </ul>  |
| Over voltage at constant speed   | E.oU3 | The over voltage stall prevention parameters are set improperly. | <ul style="list-style-type: none"> <li>◆ Ensure that the voltage limit function is enabled (04.23 )</li> <li>◆ The setting of voltage limit (04.22) is too large. Adjust it between 700 V and 770 V.</li> <li>◆ The setting of frequency gain for voltage limit (04.24) is too small. Adjust it between 30 and 50.</li> <li>◆ The setting of frequency rise threshold during voltage limit (04.26) is too small. Adjust it between 5 Hz and 20 Hz.</li> </ul> |
|                                  |       | An external force drives motor during running.                   | <ul style="list-style-type: none"> <li>◆ Cancel the external force or install a braking resistor</li> </ul>   |

|                           |       |   |   |
|---------------------------|-------|---|---|
| Pre-charge resistor fault | E.Br  | Input voltage is not in arranged range  | ◆ Arrange voltage in a reasonable range   |
| Under voltage             | E.LU  | Instantaneous power failure occurs  | ◆ Enable the power dip ride through function (10.59 ).                                      |
|                           |       | The AC drive's input voltage is not within the permissible range.                             | ◆ Adjust the voltage to normal range.   |
|                           |       | The bus voltage is abnormal.  | ◆ Contact the agent or Pentax Inverter.   |
|                           |       | The rectifier bridge, the buffer resistor, the drive board or the control board are abnormal. | ◆ Contact the agent or Pentax Inverter.   |
| AC drive overload         | E.oL1 | Load is too heavy or locked-rotor occurs on motor.  | ◆ Reduce load or check motor and mechanical conditions.                                     |
|                           |       | The AC drive power class is small.  | ◆ Replace a drive of larger power class.  |
| Motor overload            | E.oL2 | 10.01 (Motor overload protection gain) is set improperly.                                     | ◆ Set 10.01 correctly.  |
|                           |       | Load is too heavy or locked-rotor occurs on motor.  | ◆ Reduce load or check motor and mechanical conditions.                                     |
| Output phase loss         | E.PHo | Motor winding is damaged.   | ◆ Check resistance between motor wires.<br>◆ Replace motor is winding is damaged.           |
|                           |       | The cable connecting the AC drive and the motor is abnormal.                                  | ◆ Check for wiring errors and ensure the output cable is connected properly Correct wiring. |
|                           |       | The AC drive's three-phase outputs are unbalanced when the motor is running.                  | ◆ Check whether the motor three-phase winding is normal.                                    |
|                           |       | The drive board or the IGBT is abnormal.  | ◆ Contact the agent or Pentax Inverter.   |

|                            |       |   |   |
|----------------------------|-------|---|---|
| Overheat                   | E.oH1 | The ambient temperature is too high.  | ◆ Lower the ambient temperature.  |
|                            |       | The ventilation is clogged.   | ◆ Clean the ventilation.  |
|                            |       | The fan is damaged.   | ◆ Replace the cooling fan.  |
|                            |       | Thermally sensitive resistor of IGBT is damaged.  | ◆ Replace the damaged thermally sensitive resistor.                                     |
|                            |       | The AC Drive Inverter module is damaged.  | ◆ Replace the AC Drive Inverter module.   |
| Out project fault          | E.SET | External fault signal is input via S.   | ◆ Confirm that the mechanical condition allows restart (09.18) and reset the operation. |
| Communication fault        | E.CE  | Host computer is in abnormal state.   | ◆ Check the cable of host computer.   |
|                            |       | Communication cable is abnormal.  | ◆ Check the communication cables.   |
|                            |       | The serial port communication protocol (01.28) of extension communication card is set improperly.   | ◆ Set extension communication card correctly.   |
|                            |       | Communication parameters in group Pd are set improperly.  | ◆ Set communication parameters in group Pd properly.                                    |
|                            |       | After all the preceding checking are done but the fault still exists, restore the default settings. |   |
| Contactor fault            | E.CoN | Drive board and power supply are abnormal.  | ◆ Replace drive board or power supply board.  |
|                            |       | Contactor is abnormal.  | ◆ Replace contactor.  |
|                            |       | The lightning protection board is abnormal.   | ◆ Replace the lightning protection board.   |
| Current detection failure  | E.oCC | The hall is abnormal.   | ◆ Replace the hall .  |
|                            |       | The drive board is abnormal.  | ◆ Replace the drive board.  |
| Motor self learning faulty | E.TE  | Motor parameters are not set according to nameplate.  | ◆ Set motor parameters correctly according to nameplate.                                |

|                                       |         |   |   |
|---------------------------------------|---------|---|---|
|                                       |         | Motor auto-tuning times out.  | ◆ Check the cable connecting AC drive and motor.  |
|                                       |         | The encoder is abnormal.  | ◆ Check whether 02.27 (encoder pulses per revolution) is set correctly. Check whether signal lines of encoder are connected correctly and securely. |
| EEPROM read-write fault               | E.EEP   | The EEPROM chip is damaged.   | ◆ Replace the main control board.   |
| Short circuit to ground               | E.STG   | Motor is short circuited to the ground.                             | ◆ Replace cable or motor.   |
| Accumulative running time reached     | E.TIo   | Accumulative running time reaches the setting value.                | ◆ Clear the record through parameter initialization.  |
| User-defined fault 1                  | E.USE 1 | User-defined fault 1 is input via S.                                | ◆ Reset the operation.  |
| User-defined fault 2                  | E.USE 2 | User-defined fault 2 is input via virtual S                         | ◆ Reset the operation.  |
| Accumulative power reach error        | E.PUT O | Accumulative power-on time reached                                  | ◆ Use the parameter initialization function to clear the record information   |
| Load loss                             | E.LO AD | Working current <10.64  | ◆ Check whether the load is off or 10.64, 10.65 parameter set Whether to meet the actual operating conditions                                       |
| PID feedback lost during running      | E.PId   | PID feedback <11.26 set value                                       | ◆ Check PID feedback or set 11.26 properly.   |
| Pulse-by-pulse current limit fault    | E.CB C  | Load is too heavy or locked-rotor occurs on motor.                  | ◆ Reduce load or check motor and mechanical conditions  |
|                                       |         | The AC drive power class is small.                                  | ◆ Replace a drive of larger power class.  |
| Motor switchover fault during running | E.SrU N | Motor switchover via terminal during drive running of the AC drive. | ◆ Perform motor switchover after the AC drive stops.  |
| Speed error                           | E.SSD   | Encoder parameters are set improperly.                              | ◆ Set encoder parameters properly.  |

|                              |            |   |   |
|------------------------------|------------|---|---|
|                              |            | Motor auto-tuning is not performed.   | ◆ Perform motor auto-tuning.  |
|                              |            | 10.69 (detection level of speed error) and 10.70 (detection time of speed error) are set incorrectly. | ◆ Set data correctly based on actual condition  |
| Motor over speed             | E.oS       | Encoder parameters are set improperly.  | ◆ Set encoder parameters properly.  |
|                              |            | Motor auto-tuning is not performed.   | ◆ Perform motor auto-tuning.  |
|                              |            | 10.67 (Over speed detection level) and 10.68 (Over speed detection time) are set incorrectly.         | ◆ Set data correctly based on the actual situation.   |
| Motor over temperature fault | E.oH2      | 1. The temperature sensor wiring is loose<br>2. Motor temperature is too high                         | ◆ Detect temperature sensor wiring and troubleshoot<br>◆ Reduce the carrier frequency or take other cooling measures to dissipate heat to the motor |
| wrong initial position       | E.INI<br>T | The motor parameters and the actual deviation are too large   | ◆ Re-confirm whether the motor parameters are correct, focusing on whether the rated current is set too small                                       |
| High water pressure failure  | A-HP       | The feedback pressure value is greater than the high pressure alarm value setting (15.04)             | ◆ Check the feedback value of the pressure sensor   |
| Low water pressure failure   | A-LP       | The feedback pressure value is less than the low pressure alarm value setting (15.05)                 | ◆ Check the feedback value of the pressure sensor   |

# Chapter 8 RS485 Communication Protocol

## 8.1 Modbus communication protocol

### 8.1.1 Introduction

DSI-100 series inverters provide RS485 communication interface, and use the international standard MODBUS communication protocol for master-slave communication. Users can realize centralized control through PC/PLC, control host computer, etc. (setting inverter control commands, operating frequency, relevant function code parameters, monitoring inverter working status and fault information, etc.) to meet specific application requirements.

### 8.1.2 Details

#### 1. Contents of the agreement

The serial communication protocol defines the content and format of information transmitted in serial communication. It includes: host polling (or broadcast) format; host encoding method, including: function code required for action, transmission data and error checking, etc. The response of the slave also adopts the same structure, including: action confirmation, return data and error checking, etc. If the slave has an error in receiving the information, or cannot complete the action required by the master, it will organize a fault message as a response and feed it back to the master.

#### 2. Application method

The inverter is connected to the "single master and multiple slave" PC/PLC control network with RDI485 bus.

### 8.1.3 The bus structure

(1) Interface mode: RS485

(2) Transmission method:

Asynchronous serial, half-duplex transmission mode. At the same time, only one of the master and slave can send data and the other can only receive data. In the process of serial asynchronous communication, data is sent frame by frame in the form of messages.

(3) Topological structure:

Single master multi-slave system. The setting range of the slave address is 1 to 247, and 0 is the broadcast communication address. Slave addresses in the network must be unique. As shown below:

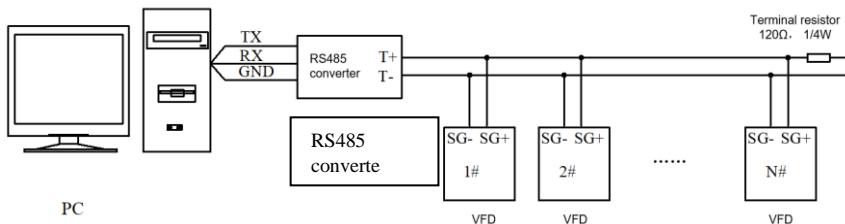

### 8.1.4 Description of the agreement

DSI-100 series inverter communication protocol is an asynchronous serial master-slave MODBUS communication protocol. Only one device (host) in the network can establish the protocol (called "query/command"). Other devices (slaves) can only respond to the "query/command" of the host by providing data, or make corresponding actions according to the "query/command" of the host. The host here refers to a personal computer (PC), industrial control equipment or a programmable logic controller (PLC), etc., and the slave refers to a 300 inverter. The master can not only communicate with a certain slave, but also publish broadcast information to all the lower slaves. For the "inquiry/command" of the host that is accessed individually, the slave must return a message (called a response). For the broadcast information sent by the host, the slave does not need to respond to the host.

### 8.1.5 Communication data structure

The MODBUS protocol communication data format of DSI-100 series inverter is divided into RTU (remote terminal unit mode).

(1) In RTU mode, the format of each byte is as follows:

Using RTU mode, message transmission starts with a pause interval of at least 3.5 character times. This is the easiest to implement with a variety of character times at the network baud rate (as shown in T1-T2-T3-T4 in the figure below). The first field of the transfer is the device address. The transfer characters that can be used are 0...9,A...F in hexadecimal. The network device continuously detects the network bus,



including the pause interval. When the first field (address field) is received, each device decodes it to determine whether it is destined for its own. After the last transmitted character, a pause of at least 3.5 character times marks the end of the message. A new message can start after this pause. The entire message frame must be transmitted as a continuous stream. If there is a pause of more than 1.5 character times before the frame is complete, the receiving device will flush the incomplete message and assume that the next byte is the address field of a new message. Likewise, if a new message follows the previous message in less than 3.5 characters, the receiving device will consider it a continuation of the previous message. This will cause an error because the value in the final CRC field cannot be correct.

RTU frame format:

|  |   |
|--|---|
| Frame header<br>START                        | T1-T2-T3-T4 (3.5 bytes transfer time)   |
| Slave address field<br>ADDR                  | Communication address: 0 ~ 247 (decimal)<br>(0 is the broadcast address)  |
| Function code field<br>CMD                   | 03H: read slave parameters;<br>06H: write slave parameters  |
| DATA field<br>DATA ( N-1 ) ...<br>DATA ( 0 ) | 2*N bytes of data, this part is the main content of communication and the core of data exchange in communication. |
| CRC CHK Low bits                             | Detection value: CRC check value (16BIT)  |
| CRC CHK High bits                            |   |
| Frame end<br>END                             | T1-T2-T3-T4 (3.5 bytes transfer time)   |

CMD (command command) and DATA (data word description) command code: 03H, read N words (Word) (up to 16 words can be read) For example: the start address of the inverter whose slave address is 01 is 0107 consecutive Read 2 consecutive values host command information RTU host command information

|                         |                                    |
|-------------------------|------------------------------------|
| START                   | T1-T2-T3-T4                        |
| ADDR                    | 01H                                |
| CMD                     | 03H                                |
| Start address high bit  | 01H                                |
| Start address low bit   | 07H                                |
| Number of data high bit | 00H                                |
| Number of data low bit  | 02H                                |
| CRC CHK low bit         | Its CRC CHK value to be calculated |
| CRC CHK high bit        |                                    |
| END                     | T1-T2-T3-T4                        |

RTU slave response information

|                             |             |
|-----------------------------|-------------|
| START                       | T1-T2-T3-T4 |
| ADDR                        | 01H         |
| CMD                         | 03H         |
| Number of bytes             | 04H         |
| DATA address 0007H high bit | 13H         |
| DATA address 0007H low bit  | 88H         |
| DATA address 0008H high bit | 13H         |
| DATA address 0008H low bit  | 88H         |

|                  |                                    |
|------------------|------------------------------------|
| CRC CHK low bit  | Its CRC CHK value to be calculated |
| CRC CHK high bit |                                    |
| END              | T1-T2-T3-T4                        |

Check method - CRC check method:

CRC (Cyclical Redundancy Check)

Using the RTU frame format, the message includes an error detection field based on the CRC method. The CRC field detects the content of the entire message. The CRC field is two bytes containing a 16-bit binary value. It is calculated by the transmitting device and added to the message. The receiving device recalculates the CRC of the received message and compares it with the value in the received CRC field. If the two CRC values are not equal, it means that there is an error in the transmission.

The CRC is stored in 0xFFFF first, and then a process is called to process the consecutive 8-bit bytes in the message with the value in the current register. Only the 8Bit data in each character is valid for CRC, and the start and stop bits and parity bits are invalid. In the process of CRC generation, each 8-bit character is XORed with the contents of the register independently, and the result is moved to the direction of the least significant bit, and the most significant bit is filled with 0. The LSB is extracted and detected. If the LSB is 1, the register is individually ORed with the preset value. If the LSB is 0, it is not performed. The whole process is repeated 8 times. After the last bit (8th bit) is completed, the next 8-bit byte is XORed with the current value of the register independently. The value in the final register is the CRC value after all bytes in the message are executed.

When the CRC is added to the message, the low byte is added first, then the high byte. The CRC simple function is as follows:

```

unsigned int crc_chk_value (unsigned char *data_value, unsigned char length)
{
    unsigned int crc_value=0xFFFF;
    int i;
    while(length-->0)
    {
        crc_value^=*data_value++;
        for(i=0;i<8;i++)
        {
            if(crc_value&0x0001)
            {
                crc_value=(crc_value>>1)
                ^0xa001;
            }
            else
            {
                crc_value=crc_value>>1;
            }
        }
    }
    return(crc_value);
}

```

## 8.2 Address Definition of Communication Parameters

This part is the content of communication, which is used to control the operation of the inverter, the status of the inverter and the setting of related parameters.

Read and write function code parameters (some function codes cannot be changed and are only used by manufacturers):

Function code parameter address marking rules:

The rules are represented by the function code group number and label as the parameter address:

High byte: 70 (00) 、 F0~FF (01-16) 、 A0~AC (18-30)

Lower byte: 00~FF

Such as: 02.10, the address is expressed as F10A (hexadecimal);

18.01, the address is represented as A001 (hexadecimal);

Note:

Group 00: Only parameters can be read, and parameters cannot be changed;

Group 16: Neither can read parameters nor change parameters; some parameters cannot be changed when the inverter is running; some parameters cannot be changed no matter what state the inverter is in; when changing the function code parameters, pay attention to the parameters The range, units, and related descriptions.

In addition, because the EEPROM is frequently stored, the service life of the EEPROM will be reduced. Therefore, some function codes do not need to be stored in the communication mode, but only need to change the value in the RAM. To realize this function, just change the high-order **F** of the function code address (01~16) to **0**, and then change the high-order **A** of the function code address (18~30) to **4**.

The following table:

| Function code group number | Function code communication access address ( EEPROM ) | Communication modification function code address (RAM) |
|----------------------------|---|--|
| 00                         | 0x7000-0x70FF   |  |
| 01~16                      | 0xF000-0xFFFF   | 0x0000-0x0FFF  |
| 18~30                      | 0xA000-0xACFF   | 0x4000-0x4CFF  |

The corresponding function code addresses are shown as follows:

High byte: 00~0F (01~16), 40~4F (18~30)

Lower byte: 00~FF

For example, the function code 02.10 is not stored in the EEPROM, and the address is expressed as 010AH; this address indicates that it can only be written to RAM, but cannot be read, and it is an invalid address when reading.

Stop/Run Parameters Section:

| Parameter address | Parameter Description                              |
|-------------------|--|
| 1000H             | * Communication setup value(-10000~10000)(Decimal) |
| 1001H             | Running frequency                                  |
| 1002H             | Bus voltage  |
| 1003H             | Output voltage                                     |
| 1004H             | Output current                                     |
| 1005H             | Output power                                       |
| 1006H             | Output torque                                      |
| 1007H             | Running speed                                      |
| 1008H             | DI input status                                    |
| 1009H             | DO output status                                   |
| 100AH             | AI1 voltage  |
| 100BH             | AI2 voltage  |
| 100CH             | AI3 voltage  |
| 100DH             | Counting value input                               |
| 100EH             | Length value input                                 |
| 100FH             | Load speed   |
| 1010H             | PID setup  |
| 1011H             | PID feedback                                       |
| 1012H             | PLC process  |
| 1013H             | PULSE input pulse frequency, unit 0.01kHz          |

|       |                                       |
|-------|---------------------------------------|
| 1014H | Feedback speed, unit 0.1Hz            |
| 1015H | Rest running time                     |
| 1016H | AI1 voltage before correction         |
| 1017H | AI2 voltage before correction         |
| 1018H | AI3 voltage before correction         |
| 1019H | Line speed                            |
| 101AH | Current power on time                 |
| 101BH | Current running time                  |
| 101CH | PULSE input pulse frequency, unit 1Hz |
| 101DH | Communication setup value             |
| 101EH | Actual feedback speed                 |
| 101FH | Main frequency X display              |
| 1020H | Auxiliary frequency Y display         |

**Caution:**

The communication setup value is percentage of the relative value, 10000 corresponds to 100.00% , -10000 corresponds to -100.00%.For data of dimensional frequency,the percentage value is the percentage of the maximum frequency.

Control command input to the inverter (write-only)

| Command word address | Command function        |
|----------------------|-------------------------|
| 2000                 | 0001: Forward operation |
|                      | 0002: Reverse operation |
|                      | 0003: Forward jog       |
|                      | 0004: Reverse jog       |
|                      | 0005: Free stop         |
|                      | 0006: Deceleration stop |
|                      | 0007: Fault reset       |

**Read inverter status: (read-only)**

| Status word address | Status word function    |
|---------------------|-------------------------|
| 3000                | 0001: Forward operation |
|                     | 0002: Reverse operation |
|                     | 0003: Stop              |

Parameters lock password check: (if the return is the 8888H, it indicates the password checksum pass)

| Password address | Contents of input password |
|------------------|----------------------------|
| 1F00             | *****                      |

The address for communication parameter initialization is 1F01H, and its data content is defined as follows:

| Parameter initialization communication address | Command content |
|--|-----------------|
|--|-----------------|

|       |                                    |
|-------|------------------------------------|
| 1F01H | 1: Restore factory parameters      |
|       | 2:Clear record information         |
|       | 4:Restoring user backup parameters |
|       | 5:Backup user current parameters   |

Digital output terminal control: (write-only)

| Command address | Command content   |
|-----------------|---|
| 2001            | BIT0: DO1 Output control<br>BIT1: DO2 Output control<br>BIT2 RELAY1 Output control<br>BIT3: RELAY2 Output control<br>BIT4: Y1R Output control<br>BIT5 :VDO1<br>BIT6 :VDO2<br>BIT7 :VDO3<br>BIT8 :VDO4<br>BIT9 :VDO5 |

Analog output AO1 control: (write-only)

| Command address | Command content          |
|-----------------|--------------------------|
| 2002            | 0~7FFF indicates 0%~100% |

Analog output AO2control: (write-only)

| Command address | Command content         |
|-----------------|-------------------------|
| 2003            | 0~7FFFindicates 0%~100% |

(PULSE) output control : (write-only)

| Command address | Command content         |
|-----------------|-------------------------|
| 2004            | 0~7FFFindicates 0%~100% |

Inverter fault description:

| fault address | fault code | fault information                      |
|---------------|------------|--|
| 8000H         |            | 0000:No fault                          |
|               |            | 0001:Reserved                          |
|               | E.oC1      | 0002:Speed-up over current (oC1)       |
|               | E.oC2      | 0003:Speed-down over current (oC2)     |
|               | E.oC3      | 0004:Constant speed over current (oC3) |
|               | E.oU1      | 0005:Speed-up over voltage (oU1)       |
|               | E.oU2      | 0006:Speed-down over voltage (oU2)     |
|               | E.oU3      | 0007:Constant speed over voltage (oU3) |
|               | E.Br       | 0008:Buffer resistance overload fault  |
|               | E.LU       | 0009:Under-voltage fault (LU)          |
|               | E.oL2      | 000A:Inverter overload (oL2)           |
|               | E.Ol1      | 000B:Motor overload (oL1)              |
|               | E.PHI      | 000C:Input phase lost (PHI)            |

|        |  |
|--------|--|
| E.PHo  | 000D:Output phase lost (PHo)                   |
| E.oH1  | 000E:IGBT Module overheating (oH1)             |
| E.SET  | 000F:External fault (EF)                       |
| E.CE   | 0010:Communication fault (CE)                  |
| E.CoN  | 0011:DC Contactor fault                        |
| E.oCC  | 0012:Current detection fault (oCC)             |
| E.TE   | 0013:Motor tuning fault (TE)                   |
| E.Enco | 0014:Encoder/PG card fault                     |
| E.EEP  | 0015:EEPROM faulty (EEP)                       |
| E.INT  | 0016:Inverter hardware fault                   |
| E.STG  | 0017:Motor earthing short-circuit fault        |
| E.BL   | 0018:Reserved                                  |
| E.oH2  | 0019:Reserved                                  |
| E.TIo  | 001A:Running time arrive fault                 |
| E.USE1 | 001B>User defined fault 1                      |
| E.USE2 | 001C>User defined fault 2                      |
| E.PUTo | 001D:Power on time arrive fault                |
| E.LOAD | 001E:Load off                                  |
| E.PId  | 001F:PID feedback lost during operation (PIDE) |
| E.CBC  | 0028:Fast current limit timeout fault          |
| E.SrUN | 0029:Motor shifting fault during operation     |
| E.SDD  | 002A:Excessive speed deviation                 |
| E.oS   | 002B:Motor over speed                          |
| E.OH2  | 002D:Motor over-temperature                    |
| E.INIT | 005A:Encoder line number setup fault           |
| E.FDB  | 005B:Encoder not connected                     |
| E.INIT | 005C:Initial position error                    |
| E.ESD  | 005D:Speed feedback fault                      |

Communication fault information describing data (fault code):

| Communication fault address | Fault function description  |
|-----------------------------|---|
| 8001                        | 0000: No fault<br>0001: Password error<br>0002: Command code error<br>0003: CRC check error<br>0004: Invalid address<br>0005: Invalid parameter<br>0006: Parameter change invalid<br>0007: The system is locked<br>0008: Operating EEPROM |

