



KROHNE

▶ measure the facts

Flow measurement

Product overview



Contents

4-5	Product selection
6-7	Overview Technology Icons
8-9	Highlights of the KROHNE devices
10-19	Electromagnetic flowmeters
20-27	Variable area flowmeters
28-37	Ultrasonic flowmeters
38-45	Mass flowmeters
46-51	Vortex flowmeters
52-59	Differential pressure flow measurement
60-65	Flow controllers
66-67	Communication technology
68-69	Services
70-71	Calibration

KROHNE trademarks:

KROHNE
measure the facts
CalSys
CARGOMASTER
EcoMATE
EGM
KROHNE Care
M-PHASE
OPTIBAR
OPTIBATCH
OPTIBRIDGE
OPTIFLEX
OPTIFLUX
OPTIMASS
OPTISENS
OPTISONIC
OPTISOUND
OPTISWIRL
OPTISWITCH
OPTISYS
OPTIWAVE
PipePatrol
WATERFLUX
SENSOFIT
SMARTBASE
SMARTMAC
SMARTPAT

Trademarks of other owners:

Amphenol
Bluetooth®
EtherNet/IP™
FDT Group
FOUNDATION™ fieldbus
HART®
HASTELLOY®
Metaglas®
PACTware
PROFIBUS®
PROFINET®
VARIVENT®
VISCOLINE®



KROHNE – your global partner

KROHNE is your reliable partner for process instrumentation and automation. As our client, you benefit from our ability to solve your applications with matching measurement solutions; we offer a complete product portfolio, industry specific system solutions and complementary services for instrumentation projects of any size.

By having specialised in industrial process measurement since 1921, we have gained an enormous amount of application knowledge in various industries that is integrated into our products, solutions and services. We have truly mastered the physical principles our meters are based on: our ability to utilise physical effects and to find a matching measuring solution time after time are the reasons we are trusted by clients worldwide. The primary measured value is as accurate as possible to avoid consecutive faults that might affect your process control. It also enables our meters to measure reliably, even under changing or difficult process conditions. Both aspects are reflected by our claim “**Measure the facts**”.

The innovative technologies we employ for your benefit are based on our extensive R&D activities: 10% of the >3700 KROHNE employees work in research and development. Next to sensor physics, their focus is on device communication and enabling technologies for the Internet of Things (IoT) in process industry, e.g. ethernet communication to transmit process and device diagnostic data for evaluation and process optimisation.

Our “Technology Icons” perfectly sum up the above mentioned advantages for you. You will find them highlighted within our complete portfolio in this brochure. If you don't find a matching solution for your measurement application, feel free to contact us, we look forward to solving it.



The solution for every application

KROHNE has unique expertise when it comes to flow measurement. We hold over 1,000 patents relating to flow products and don't just demonstrate our ability with standard applications but also with applications that are demanding, requiring custom solutions. For us, customer orientation starts as early as research and development. Many of our products which are considered today's industrial standards, were developed in cooperation with our customers. Today, users around the world benefit from KROHNE innovation: Electromagnetic flowmeters with ceramic liners for highly corrosive media in chlorine chemistry. Mass flowmeters with just one straight tube – ideal for highly viscous media and low flow speeds. Ultrasonic flowmeters for custody transfer, working according to the time-of-flight method. Vortex measuring devices with integrated pressure and temperature compensation. And variable area flowmeters: they established KROHNE's business in 1921, today we can't imagine KROHNE without them, if a local display is to ensure the redundancy and the certainty of the system.

Online configurator

For detailed device selection, take advantage of our online platform Configure It. It's quick and easy to find the right product variant for you, to check the availability of the selected product or to request a non-binding quote.

For more information about Configure It go to www.krohne-direct.com

Due to their repeatability and accuracy, our flowmeters are installed as reference-meters on standard liquid flow calibration-rigs of national metrology institutes such as PTB (Germany), NMI/EuroLoop (the Netherlands) and NMIJ (Japan).

Product selection list

This table will help you in selecting the right measuring principle for your application

	Electro-magnetic flowmeters	Variable area flowmeters	Ultrasonic flowmeters	Mass flowmeters	Vortex flowmeters	Differential pressure flow measurement	Flow controllers
	Page 10-19	Page 20-27	Page 28-37	Page 38-45	Page 46-51	Page 52-59	Page 60-65
Liquids							
Liquids (e.g. water)	x	x	x	x	x	x	x
Low flow rates	x	x	–	x	–	o	–
High flow rates	x	–	x	x	–	x	x
Non-conductive liquids	–	x	x	x	x	x	o
Viscous media	x	x	o	x	o	x	o
Gases							
Industrial gases	–	x	x	x	x	x	–
Low flow rates	–	x	o	x	–	x	–
High flow rates	–	o	x	x	x	x	–
Steam	–	o	x	o	x	x	–
Special applications							
Slurry, media with solids	x	–	–	x	–	o	–
Emulsions (oil/water)	o	x	o	x	o	x	o
Corrosive liquids (acids, alkalis)	x	x	x	x	o	x	–
Corrosive gas flows	–	o	x	o	o	x	–
Bi-directional measurements	x	–	x	x	–	x	o
Version							
2-wire	x	x	–	–	x	x	x
4-wire	x	–	x	x	–	–	–

x = suitable, o = suitable under certain conditions, – = not suitable

Technology Icons

To deliver reliable values even under difficult conditions, KROHNE products and solutions use a number of high-end technologies.

These are highlighted by the technology icons, each representing a unique and characteristic feature that also generates additional benefit for users:



Ceramic durability

By implementing oxide ceramic sensors into OPTIFLUX and BATCHFLUX electromagnetic flowmeters as well as ceramic diaphragms into OPTIBAR pressure devices, KROHNE is using a superior material that is permanently resistant to corrosive and abrasive media and also immune to temperature shocks.



EGM™ Entrained Gas Management

EGM™ was developed for the OPTIMASS Coriolis mass flowmeters to overcome problems caused by air or gas entrainments in a liquid. Powerful control algorithms maintain measurement, even during a complete transition from a pure liquid phase to a gas phase and back. Mass flow and density measurements remain stable and continuous, which has been demonstrated in batch / loading / empty-full-empty applications.

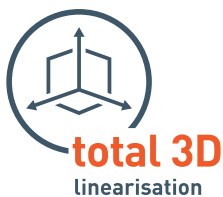

Total 3D linearisation

For a robust and accurate differential pressure measurement, even under changing process conditions, each OPTIBAR DP 7060 differential pressure transmitter is linearised in 3 dimensions during calibration: differential pressure, ambient temperature and static pressure are taken into account in combination. Since the full specified operating range is covered, an utmost stable and accurate measurement under all process conditions is guaranteed.



SmartSense insulation monitoring

Temperature assemblies with Pt100 or thermocouple sensors can produce erroneous measurements due to humidity in the measuring insert, e.g. caused by wear, corrosion or cracks. OPTITEMP temperature transmitters with SmartSense monitor the temperature sensor and warn for isolation errors.



Transmitter built-in

The SMARTPAT series of analysis sensors significantly eases the handling of analytical sensors: formerly an external device, the transmitter has now been miniaturised and built into the sensor head, enabling direct 4...20 mA/HART® 7 communication. This reduces the costs of ownership, eases installation and maintenance, and allows for usage in Ex applications (zone 0).



Flow computer built-in

Many KROHNE flowmeters have a built-in flow computer that compensates for the effects of pressure and temperature on the flow measurement or to convert to standard volume. The OPTISONIC 7300/8300 have analogue input for P & T sensors, the OPTISWIRL 4200 has both integrated. This saves both cost and installation efforts for an external flow computer.

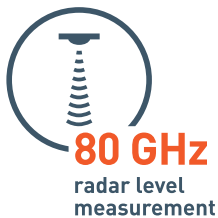

80 GHz radar level measurement

The 80 GHz technology used in the OPTIWAVE series is the most recent and versatile radar technology for level measurement of liquids and solids. Over an identical distance, it presents a highly focused beam with a smaller diameter compared to lower frequency radars, ideal for dusty atmospheres or low reflective media. The small dead zone and narrow beam angle allow for use in both small and tall vessels.



Multiphase measurement

Multiphase measurement allows for the simultaneous measurement of flow rates of oil, water and gas in multiphase mixtures, without the need of separation. This saves time, costs, space and installation efforts compared to conventional test separators. Our magnetic resonance based multiphase flowmeter M-PHASE 5000 offers a full bore, non-radioactive solution for measuring multiphase flow.



E-RTTM pipeline leak detection

E-RTTM is a leading mathematical model for continuous internal monitoring of pipelines. Integrated in our PipePatrol system, it compares measurement data from the actual pipeline with those of a simulated "virtual pipeline" in real time. If the model detects a discrepancy, a leak signature analysis using leak pattern recognition determines whether it is a leak or safe, with outstanding accuracy.

GDC concept: An electronics concept from which everybody benefits



MFC 400 for mass flowmeters
UFC 400 for ultrasonic flowmeters



IFC 300 for electromagnetic flowmeters
UFC 300 for ultrasonic flowmeters
GFC 300 for ultrasonic gas flowmeters



VFC 200 for Vortex flowmeters



IFC 100 for electromagnetic flowmeters



IFC 050 for electromagnetic flowmeters

User-friendliness is traditionally a top priority at KROHNE: whether during installation, commissioning, operation or communication – high-end technology only makes sense if it is simple and convenient for the customer to use.

That is why at KROHNE, user-friendliness begins with the electronics. Our development and application engineers have worked for years to develop a comprehensive design known as the General Device Concept – GDC for short.

What does it all mean? First of all, it features a uniform user interface to speed up the commissioning of the devices. Secondly, it boasts extensive device and process diagnostic functions, which can be exceeded by the Toolbox module. Thirdly, it's easy to integrate fieldbus interfaces such as PROFIBUS®, PROFINET® and FOUNDATION™ fieldbus thanks to the high degree of modularity. And lastly, it's an electronics package that can be used in various housing shapes.

The high-end position in terms of functionality and accuracy is occupied by the electromagnetic converter IFC 300. It offers full diagnostic capabilities and offers the maximum freedom in defining process parameters and settings for even the most complex measuring applications.

With IFC 100, its diagnostic capabilities and its hazardous area approvals we offer a sophisticated solution for general applications. Optionally it even provides communication protocols like PROFIBUS®, FOUNDATION™ fieldbus and Modbus.

The IFC 050 is the all-purpose device which boasts outstanding performance. Not only when it comes to measuring accuracy and diagnostics but also defines a new benchmark in terms of the price-performance ratio.

The converter MFC 400 is a further development of the GDC concept, providing new performance features such as Entrained Gas Management™ for mass flowmeters, and SIL2/3.

The most recent member of the GDC family is the VFC 200. The converter for Vortex flowmeters is the first 2-wire device in this group and – thanks to its development according to the latest edition of IEC 61508 – ideally suitable for safety-related applications (SIL2).

Human Machine Interface (HMI): Simply clever, simply well thought-out

User-friendliness begins with selecting the right display and control elements.

All devices feature a large, high-contrast display which makes it possible to display plain text information as well as graphic information such as the trend development of the flow.

Operation is simple and convenient thanks to a user-friendly interface with four optical buttons. Not only does it look good – it's also extremely practical.



For example, the glass cover which protects the display from dirt and dust does not have to be removed during parameterization or operation. Using the Quick Setup menu, the user can quickly adapt the OPTIFLUX to the application.

The converter can communicate with the user in many languages including German, English, French and Spanish.

OPTICHECK: Service tool for in-situ verification of KROHNE devices

The OPTICHECK is the essential tool for making sure that your installed flowmeters are performing to specification. When you connect the tool in-line on site, it gathers measuring data to ensure that the flowmeter is performing within 1 % of the factory calibration. The baseline can be historic repair data from the factory or on-site test results after performing a full verification.



Modular product lines: Many combinations for one customised solution

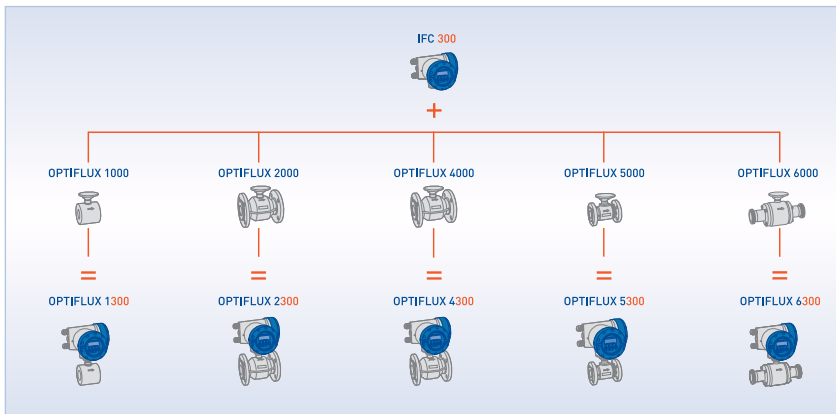

At KROHNE, we believe in the concept of modularity when it comes to offering our customers the measuring solution best suited to their process. Both our IFC and MFC converters can be freely combined with all devices in the OPTIFLUX and OPTIMASS lines. This modularity is also reflected in the names of the devices. For example, the OPTIFLUX 1300 is a combination of the OPTIFLUX 1000 sensor and the IFC 300 converter.

The modular product line

Converters



IFC 050 C Display/Blind:
Basic applications



IFC 050 W Display/Blind:
Wall-mounted



IFC 100 C
Standard applications



IFC 100 W
Wall-mounted



IFC 300 C
Advanced applications



IFC 300 F
Field housing



IFC 300 W
Wall-mounted



IFC 300 R
Rack-mounted

Flow sensors



OPTIFLUX 1000
Sandwich (wafer) device
for compact installation



OPTIFLUX 2000
For water and wastewater
applications



WATERFLUX 3000
For small and large flows
without requiring inlets or
outlets



OPTIFLUX 4000
For standard and advanced
process and custody transfer
applications



OPTIFLUX 5000 sandwich, flange
Ceramic measuring tube:
maximum media and abrasion
resistance and accuracy



OPTIFLUX 6000
For hygienic food and
pharmaceutical applications

The specialists



OPTIFLUX 7300 C sandwich, flange
With non wetted capacitive electrodes and ceramic liner



BATCHFLUX 5500
For volumetric filling systems in the beverage industry



POWERFLUX 4000
For nuclear applications



POWERFLUX 5000
For nuclear applications, with ceramic measuring tube



TIDALFLUX 2300 F
For partially filled pipelines, Ex Zone 1



WATERFLUX 3070
Battery-powered water meter for district metering and custody transfer



ENVIROMAG 2000
Engineered for the North American water and wastewater industry with NSF approval for potable water

Accessories



OPTICHECK
Service tool for in-situ verification of field devices

Electromagnetic flowmeters

Highlights:

- Minimal or no inlets/outlets
- All KROHNE EMF are wet-calibrated in a direct comparison of volumes
- Large choice of liner materials suitable for potable water, wastewater, chemicals, SIP/CIP
- Measurement independent of flow profile
- Custody transfer approvals
- Abrasion and corrosion resistant liners
- Ceramic measuring tubes and liners for flange and sandwich versions, also with non-wetted electrodes (capacitive flowmeter)
- Standard device for partially filled pipes
- 4-wire, 3 x 4...20 mA, HART®, Modbus, FF, PROFIBUS®-PA/DP, PROFINET etc.
- Virtual reference option: grounding electrodes and grounding rings can be left out
- Electrical conductivity of media can be used for detection of product change
- For high bubble content, high solids content and pulsating flow
- Secure handling of rapid media changes and pH jumps
- Zero-point stability regardless of changes in media properties
- Nominal sizes DN2.5...3000/ 1/10...120"
- 3x100% diagnostics (application and device diagnostic, out-of-spec test) exceeds NAMUR requirements

Electromagnetic flowmeters

The measuring principle

As early as 1832, Michael Faraday tried to determine the speed of the current in the Thames by measuring the voltage induced in flowing water by the earth's magnetic field. Electromagnetic flow measurement is based on Faraday's law of induction. According to this law, a voltage is induced when an electric conductive fluid flows through the magnetic field of an electromagnetic flowmeter. This voltage is proportional to the flow velocity of the medium.

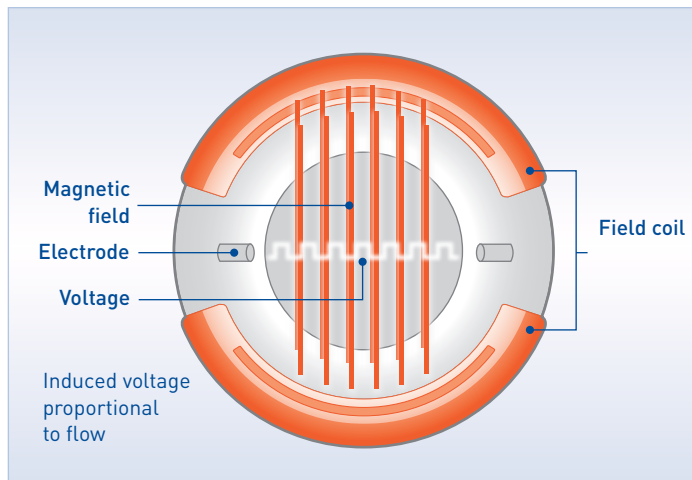

The induced voltage is picked up either by two electrodes in contact with the medium or by capacitive electrodes with no contact to medium and supplied to a signal converter.

A signal converter amplifies the signal and converts it into a standard signal (4...20 mA) as well as to a frequency/pulse signal (e.g. one pulse for every cubic meter of measured medium that flows through the measuring tube).

The standard for the competition: Electromagnetic flowmeters from KROHNE

As founder and world market leader in electromagnetic flowmeter technology, we have been impressing our customers with innovation for more than 60 years, innovations that continue to set the standard for the competition. Our OPTIFLUX product line is an excellent example of this: a converter for all applications. A one-of-a-kind diagnostics package that can even look into the process. An intuitive operating concept featuring a quick start function for simple start-up.

Thanks to this unique combination of high-end technology and maximum user-friendliness, you will benefit in a wide range of industries: in the food and beverage industry, where fruit juices, milk and liquid hops must be mixed, dosed and filled under hygienic conditions. In the chemicals industry and in the pulp and paper industry, where our devices deal with acids, alkalis, pastes, sludges and other caustic media, or in the metal and mining industry where media with a high solid content are encountered on a daily basis.

We produce electromagnetic flowmeters in our plants in the Netherlands, Brazil, India and China. It is no wonder that the Physikalisch-Technische Bundesanstalt (PTB) in Braunschweig, Germany, relies on electromagnetic flowmeters from KROHNE in their calibration systems.

Industries:

- Water & Wastewater
- Chemical
- Food & Beverage
- Pharmaceutical
- Power Generation
- Pulp & Paper
- Metal & Mining

OPTIFLUX 4300 in the filtration system in the Haltern waterworks, Germany





Production process of high-performance ceramics

Electromagnetic flow measurement: Increased safety through the use of high-performance ceramics in flange design



The converter is not the only critical factor in the reproducibility of the measured value during electromagnetic flow measurement. The form stability of the measuring tube under temperature and pressure stresses also plays an important role. To obtain a reliable measurement even with critical media, the measuring tube material, the electrode construction and the process connection must all be taken into account.

The challenge: The new measuring tube material should be highly resistant to caustic, corrosive and abrasive media and show off its superiority to conventional liners made of plastic such as PFA.

KROHNE accepted this challenge and, in close cooperation with FRIATEC AG from Mannheim, Germany, developed a high-performance ceramics for industrial use which can even withstand rapid temperature changes and high mechanical stresses.

When it comes to measuring critical media such as those used in chlorine chemistry, it was also necessary to optimise the electrode construction. The result of these efforts? Using the so-called Cermet electrode has made it possible to develop a 100 % gap-free design. In doing so, the metal of the electrode combines with the material of the ceramic to form an insoluble compound when exposed to high temperatures.

In addition to the sandwiched version, our engineers also developed a flanged version. This version not only guarantees easy installation but also minimises the risk of leakage in case of a fire.

It is no wonder that the fields of application of the ceramic electromagnetic flowmeter are so numerous today. They range from measuring acids and alkalis in chemistry to usage in chlorine chemistry, to the volumetric filling of liquids in the beverage, pharmaceutical and cosmetics industries.

Electromagnetic flowmeters: 3x100% diagnostics for maximum certainty

Resistance measurement
for detecting electrode covering, electrode short-circuit, excessively low conductivity and for measuring the conductivity and the coil temperature (media temperature)

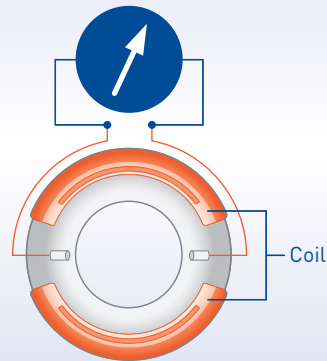

KROHNE offers its customers complete application and process diagnostics as well as an accuracy and linearity test (out-of-spec diagnostics) in addition to the usual device diagnostics for the OPTIFLUX line.

With the indicators supplied by OPTIFLUX and knowledge of the process, the user can detect the following application problems with a high degree of certainty:

- Gas bubbles
- Electrode corrosion, deposits on electrodes
- Short-circuit
- Low conductivity of measured medium
- Partial filling of measuring tube
- Liner damage
- External disrupting magnetic fields
- Disrupted flow profile

Accuracy test
by means of a cyclically fed test signal

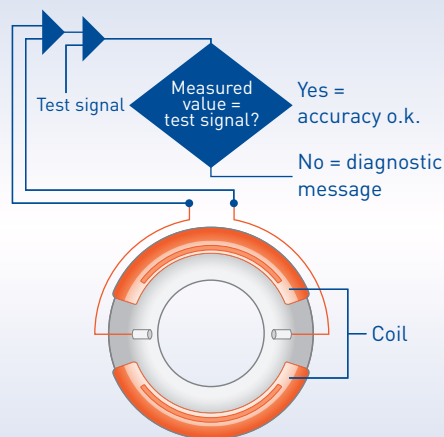

During the out-of-spec test, a determination is made, both online and cyclically, as to whether the device is still within its specifications. In particular, the accuracy is tested by feeding a test signal. The linearity of the device and the accuracy of the field current with which the magnetic field is generated are also checked.

Thanks to the 3x100% diagnostics, the OPTIFLUX is much more than a simple flowmeter: it examines the process and provides the user with valuable information. In this respect, the OPTIFLUX even exceeds the requirements of VDI/VDE/NAMUR 2650.

Magnetic field polarity reversal
for checking the flow profile and for detecting a partially filled measuring tube

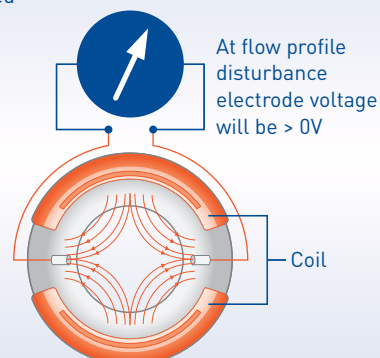

The modular product line

	Sandwich (wafer) device for compact installation	For water and wastewater applications	For small and large flows without requiring inlets or outlets
	OPTIFLUX 1050	OPTIFLUX 2050	WATERFLUX 3050
	OPTIFLUX 1000 + IFC 050 	OPTIFLUX 2000 + IFC 050 	WATERFLUX 3000 + IFC 050 
Measuring accuracy	±0.5% of measured value above 0.5 m/s; depending on measuring sensor ±2.5 mm/s below 0.5 m/s; independent of measuring sensor	±0.5% of measured value above 0.5 m/s; depending on measuring sensor ±2.5 mm/s below 0.5 m/s; independent of measuring sensor	±0.5% of measured value above 0.5 m/s; depending on measuring sensor ±2.5 mm/s below 0.5 m/s; independent of measuring sensor
Electrical conductivity	≥5 µS/cm (water ≥20 µS/cm)	≥5 µS/cm (water ≥20 µS/cm)	≥5 µS/cm (water ≥20 µS/cm)
Process conditions	Solid content <10%	Solid content <10%	Solid content <10%
Outputs	Current, pulse, status	Current, pulse, status	Current, pulse, status
Power supply	100...230 VAC, 24 VDC	100...230 VAC, 24 VDC	100...230 VAC, 24 VDC
Protection category: Compact (C) Wall (W)	IP66, 67; NEMA 4, 4X -	IP66, 67; NEMA 4, 4X -	IP66, 67; NEMA 4, 4X -
	OPTIFLUX 1100	OPTIFLUX 2100	WATERFLUX 3100
	OPTIFLUX 1000 + IFC 100 	OPTIFLUX 2000 + IFC 100 	WATERFLUX 3000 + IFC 100 
Measuring accuracy	±0.3% of measured value	±0.3% of measured value	±0.3% of measured value
Electrical conductivity	≥5 µS/cm (water ≥20 µS/cm)	≥5 µS/cm (water ≥20 µS/cm)	≥20 µS/cm
Process conditions	Solid content max. 10%	Solid content max. 10%	Clean drinking water
Outputs	Current, pulse, status	Current, pulse, status	Current, pulse, status
Inputs	Binary	Binary	Binary
Communication	HART®, FF, PA, DP, Modbus	HART®, FF, PA, DP, Modbus	HART®, FF, PA, DP, Modbus
Power supply	100...230 VAC, 12...24 VDC, 24 VAC/DC	100...230 VAC, 12...24 VDC, 24 VAC/DC	100...230 VAC, 12...24 VDC, 24 VAC/DC
Protection category: Compact (C) Field (F)	IP66, 67; NEMA 4X, 6 -	IP66, 67; NEMA 4X, 6 -	IP66, 67; NEMA 4, 4X, 6 IP66, 67; NEMA 4, 4X, 6
	OPTIFLUX 1300	OPTIFLUX 2300	WATERFLUX 3300
	OPTIFLUX 1000 + IFC 300 	OPTIFLUX 2000 + IFC 300 	WATERFLUX 3000 + IFC 300 
Measuring accuracy	±0.3% of measured value	±0.2% of measured value	±0.2% of measured value
Electrical conductivity	≥1 µS/cm (water ≥20 µS/cm)	≥1 µS/cm (water ≥20 µS/cm)	≥20 µS/cm
Process conditions	Solid content max. 70%	Solid content max. 70%	Clean drinking water
Outputs	Current, pulse, status	Current, pulse, status	Current, pulse, status
Inputs	Binary	Binary	Binary
Communication	HART®, FF, PA, DP, Modbus, PROFINET®	HART®, FF, PA, DP, Modbus, PROFINET®	HART®, FF, PA, DP, Modbus, PROFINET®
Power supply	85...250 VAC, 11...31 VDC, 20.5...26 VAC/DC	85...250 VAC, 11...31 VDC, 20.5...26 VAC/DC	100...230 VAC, 12...24 VDC, 24 VAC/DC
Protection category: Compact (C) Field (F) Wall (W) 19" Rack (R)	IP66, 67; NEMA 4, 4X, 6 IP66, 67; NEMA 4, 4X, 6 IP65; NEMA 4, 4X IP20; NEMA 1	IP66, 67; NEMA 4, 4X, 6 IP66, 67; NEMA 4, 4X, 6 IP65; NEMA 4, 4X IP20; NEMA 1	IP66, 67; NEMA 4, 4X, 6 IP66, 67; NEMA 4, 4X, 6 IP65; NEMA 4, 4X IP20; NEMA 1
Measuring sensor	OPTIFLUX 1000	OPTIFLUX 2000	WATERFLUX 3000
	OPTIFLUX 1000 	OPTIFLUX 2000 	WATERFLUX 3000 
Process connection EN 1092-1	DN10...150; PN16, 40	DN25...3000; PN2.5...40	DN25...300; PN10, 16; DN350...600; PN10
Process connection ASME B16.5	3/8...6"; CL 150, 300	1...120"; CL 150, 300	1...12"; CL 150; 14"...24" CL 150 (10 bar/145 psi rated)
Process temperature	-25...+120°C/-13...+248°F	-5...+90°C/+23...+194°F	-5...+70°C/+23...+158°F
Ambient temperature	-25...+65°C/-13...+149°F	-40...+65°C/-40...+149°F	-40...+65°C/-40...+149°F
Materials liner	PFA	Polypropylen, hard rubber, Polyolefin (PO)	DN25...600: Rilsan
Materials electrodes	Hastelloy®	Hastelloy®, titanium, stainless steel	Stainless steel 1.4301; AISI 304
Sensor	IP66, 67; NEMA 4, 4X	IP66, 67, 68; NEMA 4, 4X, 6, 6P	IP66, 67, 68; NEMA 4, 4X, 6, 6P
Ex-Approvals	-	Ex, FM, CSA	-
Other approvals	FDA, MI-001, MI-005	KTW, WRAS, KIWA, ACS, OIML R49, MI-001, MI-005	ACS, DVGW, TZW/UBA, NSF, WRAS, MI-001

For standard and advanced process and custody transfer applications	Ceramic measuring tube: maximum media and abrasion resistance and accuracy	Ceramic measuring tube: maximum media and abrasion resistance and accuracy	For hygienic food and pharmaceutical applications
			OPTIFLUX 6000
			OPTIFLUX 6000 + IFC 050 
-	-	-	±0.5% of measured value above 0.5 m/s; depending on measuring sensor ±2.5 mm/s below 0.5 m/s; independent of measuring sensor
-	-	-	≥5 μS/cm (water ≥20 μS/cm)
-	-	-	Solid content <10%
-	-	-	Current, pulse, status
-	-	-	100...230 VAC, 24 VDC
-	-	-	IP66, 67; NEMA 4, 4X
-	-	-	-
OPTIFLUX 4100	OPTIFLUX 5100 sandwich	OPTIFLUX 5100 flange	OPTIFLUX 6100
OPTIFLUX 4000 + IFC 100 	OPTIFLUX 5000 + IFC 100 	OPTIFLUX 5000 + IFC 100 	OPTIFLUX 6000 + IFC 100 
±0.3% of measured value	±0.3% of measured value	±0.3% of measured value	±0.3% of measured value
≥5 μS/cm (water ≥20 μS/cm)	≥5 μS/cm (water ≥20 μS/cm)	≥5 μS/cm (water ≥20 μS/cm)	≥5 μS/cm (water ≥20 μS/cm)
Solid content max. 10%	Solid content max. 10%	Solid content max. 10%	Solid content max. 10%
Current, pulse, status	Current, pulse, status	Current, pulse, status	Current, pulse, status
-	-	-	-
-	-	-	-
100...230 VAC, 12...24 VDC, 24 VAC/DC	100...230 VAC, 12...24 VDC, 24 VAC/DC	100...230 VAC, 12...24 VDC, 24 VAC/DC	100...230 VAC, 12...24 VDC, 24 VAC/DC
IP66, 67; NEMA 4X, 6	IP66, 67; NEMA 4X, 6	IP66, 67; NEMA 4X, 6	IP66, 67; NEMA 4X, 6
-	-	-	-
OPTIFLUX 4300	OPTIFLUX 5300 sandwich	OPTIFLUX 5300 flange	OPTIFLUX 6300
OPTIFLUX 4000 + IFC 300 	OPTIFLUX 5000 + IFC 300 	OPTIFLUX 5000 + IFC 300 	OPTIFLUX 6000 + IFC 300 
±0.2% of measured value	±0.15% of measured value	±0.15% of measured value	±0.2% of measured value
≥1 μS/cm (water ≥20 μS/cm)	≥1 μS/cm (water ≥20 μS/cm)	≥1 μS/cm (water ≥20 μS/cm)	≥1 μS/cm (water ≥20 μS/cm)
Solid content max. 70%	Solid content max. 70%	Solid content max. 70%	Solid content max. 70%
Current, pulse, status	Current, pulse, status	Current, pulse, status	Current, pulse, status
Binary	Binary	Binary	Binary
HART®, FF, PA, DP, Modbus, PROFINET®	HART®, FF, PA, DP, Modbus, PROFINET®	HART®, FF, PA, DP, Modbus, PROFINET®	HART®, FF, PA, DP, Modbus, PROFINET®
85...250 VAC, 11...31 VDC, 20.5...26 VAC/DC	85...250 VAC, 11...31 VDC, 20.5...26 VAC/DC	85...250 VAC, 11...31 VDC, 20.5...26 VAC/DC	85...250 VAC, 11...31 VDC, 20.5...26 VAC/DC
IP66, 67; NEMA 4, 4X, 6 IP66, 67; NEMA 4, 4X, 6 IP65; NEMA 4, 4X IP20; NEMA 1	IP66, 67; NEMA 4, 4X, 6 IP66, 67; NEMA 4, 4X, 6 IP65; NEMA 4, 4X IP20; NEMA 1	IP66, 67; NEMA 4, 4X, 6 IP66, 67; NEMA 4, 4X, 6 IP65; NEMA 4, 4X IP20; NEMA 1	IP66, 67; NEMA 4, 4X, 6 IP66, 67; NEMA 4, 4X, 6 IP65; NEMA 4, 4X IP20; NEMA 1
OPTIFLUX 4000	OPTIFLUX 5000 sandwich	OPTIFLUX 5000 flange	OPTIFLUX 6000
OPTIFLUX 4000 	OPTIFLUX 5000 	OPTIFLUX 5000 	OPTIFLUX 6000 
DN2.5...2,000; PN6...40	DN2.5...100; PN16, 40	DN15...300; PN10, 16, 40	DN2.5...150; hygienic connections
1/10...80"; CL 150, 300, 600, 900, 1500	1/10...4"; CL 150, 300	1/2...12"; CL 150, 300	1/10...6"; hygienic connections
-40...+180°C/-40...+356°F	-40...+180°C/-76...+356°F	-40...+180°C/-76...+356°F	-40...+180°C/-40...+356°F
-40...+65°C/-40...+149°F	-40...+65°C/-40...+149°F	-40...+65°C/-40...+149°F	-40...+65°C/-40...+149°F
PFA, PTFE, ETFE and hard rubber, PU	Aluminum oxide, Zirconium oxide	Aluminum oxide, Zirconium oxide	PFA
Hastelloy®, titanium, tantalum, stainless steel, platinum, low noise	Cermet	Cermet «DN150/6", stainless steel, HC4, titanium, tantalum, platinum ≥DN150/6"	Hastelloy®, stainless steel, titanium, tantalum, platinum
IP66, 67, 68; NEMA 4, 4X, 6, 6P	IP66, 67, 68; NEMA 4, 4X, 6, 6P	IP66, 67, 68; NEMA 4, 4X, 6, 6P	IP66, 67, 68; NEMA 4, 4X, 6, 6P
Ex, FM, CSA	Ex, FM, CSA	Ex, FM, CSA	Ex, FM, CSA
FDA, OIML R49, R117, KIWA, MI-001, MI-005	FDA, MI-001, MI-005	FDA, MI-001, MI-005	FDA, 3A, EHEDG, MI-005

The specialists

	For partially filled pipelines, Ex Zone 1	Battery-powered water meter for district metering and custody transfer	With non wetted capacitive electrodes and ceramic liner
	TIDALFLUX 2300 F	WATERFLUX 3070	OPTIFLUX 7300 C sandwich, flange
			
Signal converter	IFC 300 F	IFC 070	IFC300 C/CAP
Measuring accuracy	±1% of full scale	±0.2% of measured value	± 0.5% of measured value ± 5 mm/s
Electrical conductivity	≥50 µS/cm (water ≥50 µS/cm)	>20 µS/cm	0.05 µS/cm (demineralised cold water ≥1 µS/cm)
Process conditions	Solid content max. 70%	Clean water	Solid content max. 70%; gas content max. 5%
Outputs	Current, pulse, status	Pulse, status	Current, pulse, status, frequency, limit switch
Inputs	Binary	-	Control, current
Communication	HART®, Modbus, PROFINET®	Datalogger/GSM (option)	HART®, FF, PA, DP, Modbus, PROFINET®
Power supply	24, 115/120, 230/240 VAC	1 or 2 internal battery, external battery, up to 15 years battery lifetime	100...230 VAC, 24 VDC, 24 VAC/DC
Protection category: Compact (C) Field (F) Wall (W) 19" Rack (R)	IP67; NEMA 4, 4X - - -	IP67, 68; NEMA 4X, 6, 6P IP66, 67; NEMA 4X, 6 - -	IP66, 67; NEMA 4, 4X, 6 - - -
Approvals	Ex Zone 1	OIML R49, MI-001	-
Signal converter			
Measuring accuracy	-	-	-
Electrical conductivity	-	-	-
Process conditions	-	-	-
Outputs	-	-	-
Inputs	-	-	-
Communication	-	-	-
Power supply	-	-	-
Protection category: Compact (C) Field (F) Wall (W)	- - -	- - -	- - -
Measuring sensor	TIDALFLUX 2000	WATERFLUX 3000	OPTIFLUX 7000
Process connections			
EN 1092-1	DN200...1800; PN6, 10	DN25...300; PN10, 16; DN350 ...600; PN10 14" ...24": CL 150 (10 bar/145 psi rated)	DN25...80, 100; PN16, 40
ASME B16.5	8...72"; CL 150, 300	1...12"; CL 150	1...4"; 150 lb
Temperature ranges			
Process	-5...+60°C/+23...+140°F	-5...+70°C/+23...+158°F	-40...+100°C/-40...+212°F
Ambient	-40...+65°C/-40...+149°F	-40...+65°C/-40...+149°F	-40...+65°C/-40...+149°F
Materials			
Liner	Polyurethane	DN25...600: Rilsan	Ceramic
Electrodes	Hastelloy® C22, stainless steel	Stainless steel 1.4301; AISI 304	Non wetted, capacitive
Sensor housing	-	-	-
Protection category			
Measuring sensor	IP67, 68; NEMA 4, 4X, 6, 6P	IP66, 67, 68; NEMA 4, 4X, 6, 6P	IP66, 67; NEMA 4, 4X, 6
Approvals			
Ex (with signal converter)	Ex Zone 1	-	ATEX
Other approvals	-	ACS, DVGW, TZW/UBA, NSF, WRAS, OIML R49, MI-001	Conform FDA regulations

Engineered for the North American water and wastewater industry with NSF approval for potable water	For volumetric filling systems in the beverage industry	For nuclear applications	For nuclear applications, with ceramic measuring tube
ENVIRONMAG 2000	BATCHFLUX 5500	POWERFLUX 4030/4300 F	POWERFLUX 5000
			
IFC 300	IFC 500	AFC 030	AFC 030
±0.2% of measured value	±0.2% of measured value	± 1% of measured value	± 1% of measured value
≥1 μS/cm (water ≥20 μS/cm)	≥5 μS/cm (water ≥20 μS/cm)	Water: ≥ 20 μS/cm Non water: ≥ 1 μS/cm	Water: DN2.5...100: ≥ 20 μS/cm Non water: DN25...100 : ≥ 1 μS/cm, DN4...15: ≥ 5 μS/cm, DN2.5: ≥ 10 μS/cm.
Solid content max. 70%	Water...milk	Solid content ≤ 10%, gas content ≤ 3%	Solid content ≤ 10%, gas content ≤ 3%
Current, pulse, status	Frequency	Current	Current
Binary	-	-	-
HART®, FF, PA, DP, Modbus, PROFINET®	-	-	-
85...250 VAC, 11...31 VDC, 20.5...26 VAC/DC	24 VDC	85...250 VAC, 50/60 Hz	85...250 VAC, 50/60 Hz
IP66, 67; NEMA 4, 4X, 6 IP66, 67; NEMA 4, 4X, 6 IP65; NEMA 4, 4X IP20; NEMA 1	DN2.5, 4, 6, 25, 40: IP66, 67; NEMA 4, 4X, 6 DN10, 15: IP69K; NEMA 6P - - -	- - IP65, 66; NEMA 4, 4X - -	- - IP65, 66; NEMA 4, 4X - -
-	-	-	-
		IFC 300 F	IFC 300 F
-	-	DN2.5...15: ± 0.3% of MV + 2 mm/s, DN25...1000: ± 0.2% of MV + 1 mm/s	< DN10 / 3/8" : 0.3% of measured value + 2 mm/s, DN10...100 / 3/8...4" : 0.15% of measured value + 1 mm/s
-	-	Water: ≥ 20 μS/cm Non water: ≥ 1 μS/cm	Water: DN2.5...100: ≥ 20 μS/cm Non water: DN25...100 : ≥ 1 μS/cm, DN4...15: ≥ 5 μS/cm, DN2.5: ≥ 10 μS/cm
-	-	Solid content ≤ 10%, gas content ≤ 3%	Solid content ≤ 10%, gas content ≤ 3%
-	-	Current, pulse, status	Current, pulse, status
-	-	Binary	Binary
-	-	HART®, FF, PA, DP, Modbus, PROFINET®	HART®, FF, PA, DP, Modbus, PROFINET®
-	-	85...250 VAC, 11...31 VDC, 20.5...26 VAC/DC	85...250 VAC, 11...31 VDC, 20.5...26 VAC/DC
-	-	IP66, 67; NEMA 4, 4X, 6 IP65; NEMA 4, 4X IP20; NEMA 1	IP66, 67; NEMA 4, 4X, 6 IP65; NEMA 4, 4X IP20; NEMA 1
-	-	-	-
	POWERFLUX 4030	POWERFLUX 4000	POWERFLUX 5000
DN 25 to 2000; PN2.5...40	DN2.5...40	DN2.5...1000 in PN6...40	DN2.5...80: PN40, DN100: PN16
1...80": CL 150, 300	1/10...1 1/2"	1/10...40" in 150-900 lbs RF	1/10...4": 150 lb, 300 lbs
-5...+90°C/+23...+194°F	-20...+140°C/-4...+284°F	-40...+120°C/-40...+248°F -40...+180°C/-40...+356°F	-40...+180°C/-40...+356°F, Size DN 2.5...15: -20...+180°C/-40...+356°F
-40...+65°C/-40...+149°F	0...+60°C/+32...+140°F	-40...+55°C/-40...+130°F	-40...+180°C/-40...+356°F, Size DN 2.5...15: -20...+180°C/-40...+356°F
Polypropylen, hard rubber, Polyurethane	Zirconium dioxide	ETFE, DN25...1000; PFA, DN2.5...15	Ceramic
Hastelloy®, stainless steel	Cermet	Hastelloy®C , Platinum, stainless steel, titanium, tantalum, low noise	DN2.5...25: Cermet, DN40...100: Platinum
	-	Stainless steel, other materials on request	DN2.5...15: stainless steel 1.4408, DN25...100: stainless steel 1.4301
IP66, 67, 68; NEMA 4, 4X, 6, 6P	DN2.5, 4, 6, 25, 40: IP66, 67; NEMA 4, 4X, 6; DN10, 15: IP69K; NEMA 6P	IP66,67; NEMA 4, 4X, 6	IP66,67; NEMA 4, 4X, 6
Ex, FM, CSA	-	-	-
OIML R49, NSF	3A, FDA	TID 5E+06 Rad (ETFE), TID 1E+06 Rad (PFA), IEC 61000-4, EN60068-2-6, IEC 60980 - 1989 [300 m/s²], IEC 68-2-64, IEC 68-2-34, IEC 68-2-27	TID 1E+08 Rad, IEC 61000-4, EN 60068-2-6, IEC 60980 - 1989 [300 m/s²], IEC 68-2-64, IEC 68-2-27

Glass devices



DK46, 47, 48, 800
For low flow gas or liquid
applications and sample flow
monitoring



VA40
For basic applications



VA45
For low pressure
gas applications



K20
Plastic tube, for basic
water applications

Metal devices



H250 M40
For liquids and gases, modular design from mechanical to fieldbus



H250 M8
For liquids and gases, mechanical or with electronic bargraph indicator



DK32/34
For low liquid and gas flows, compact mechanical indicator, optional MIN/MAX switches and needle valve



DK37 M8
For advanced low liquid and gas flows, mechanical or with electronic indicator

Variable area flowmeters

Highlights:

- Local indication without the need for auxiliary power
- Use in hazardous areas
- Accurate measurement even at very low flow rates (<0.5 l/h)
- Extended turndown ratio up to 100:1
- Suitable for low operating pressures
- Can be used even with short or no straight inlets/outlets
- Modular display and measuring transducer concept: easy component replacement
- Hygienic stainless steel design without dead spaces and stagnation zones
- Flowmeters for nuclear power plants meet requirements of KTA 1401, RCC-E, RCC-M and ASME Section III and we are authorized to manufacture products with ASME N stamp and NPT stamp
- SIL2 certified
- Any meter orientation possible: vertical, horizontal or in fall pipes
- Optional limit switches, current output, totalizer, communication interfaces

Variable area flowmeters

The measuring principle

Variable area flowmeters are suitable for the measuring of clean liquids and gases. They consist of upright conical tube made of metal, glass or plastic, in which a sophisticated float moves freely up and down. The flow goes through the tube, which is applied from the bottom to top, causes the float to rise until the forces are in equilibrium.

Three forces are acting on the float:

- The buoyancy force B , which depends on the density of the medium and the volume of the float.
- The gravity force G , which depends on the mass of the float.
- The flow force F which depends on the float shape and the flow velocity through the variable area between float and tube.

Every flow rate corresponds to a defined variable area resulting from the conical shape of the measuring tube and the specific position of the float. With glass cones, the flow value can be read directly from a scale at the level of the float. With metal cones, the float position is transmitted to an indicator by magnetic means. There is no need for auxiliary power. Different measuring ranges are realised through variations in cone sizes and shapes and in selecting different float shapes and materials.

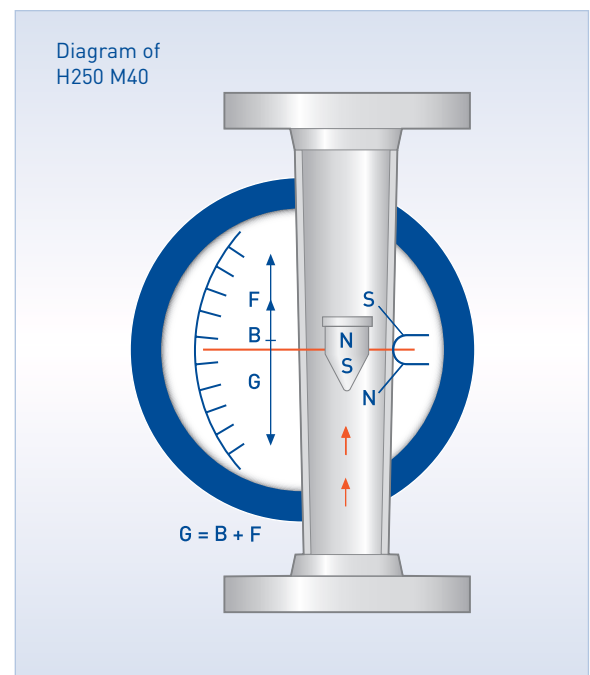
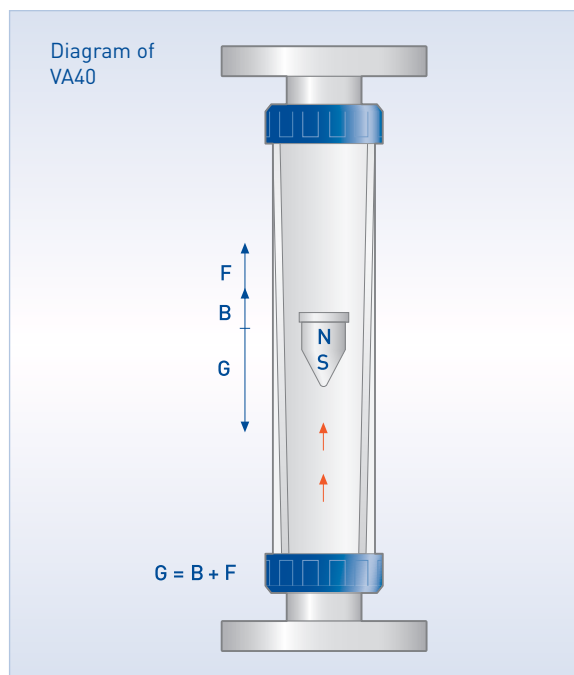

Maximum reliability when measuring liquids and gases – Since 1921

Since 1921, the name KROHNE has not only stood for innovative and reliable process measuring technology solutions, but also for exact, reliable and long-lasting variable area measuring technology.

Today, as the world's market leader, we cover a variety of applications with our comprehensive product portfolio of metal, glass and plastic cones.

Typical applications include:

- Measurement of additives such as catalysts, surfactants, foam and corrosion inhibitors, caustic soda, chlorine or sulphur substances, etc.
- Inerting of tanks or containers
- Measurement and dispensing of rinsing mediums (purge meters)
- Sample feed measurement for analyser systems
- Monitoring of lubricants and coolants for bearings and seals for process pumps and rotating machinery
- Hygienic applications in the food and pharmaceutical industries
- Measurement of gases and chemicals in laboratories and test facilities
- Gas/oil burner consumption measurement

For over 30 years, KROHNE has been a reliable partner for nuclear power plant operators and system builders. In this field, KROHNE meets the requirements of KTA 1401, RCC-E, RCC-M and ASME Section III. This authorizes us to mark products with the N stamp and NPT stamp.

Industries:



- Chemical
- Petrochemical
- Mechanical and plant engineering
- Offshore plants
- Pharmaceutical
- Food & Beverage
- Water & Wastewater
- Power Generation

Measuring the flow of CO₂ in the inlet lines of the storage tanks in the beverage industry



Metal devices

	For liquids and gases, mechanical	For liquids and gases, with electronic bargraph indicator	For liquids and gases, modular design from mechanical to fieldbus
	H250 M8M	H250 M8E	H250 M40
			
Measuring accuracy (VDI/VDE 3513-2)	1.6%	1.6%	1.6%
Outputs	-	4...20 mA	4...20 mA
Limit switches	2	via HART®	2
Totaliser	-	via HART®	11 digit, pulse output
Communication	-	HART®	HART®, FF, PA
Power supply	-	14.8...30 VDC, (2-wire)	12...30 VDC, (2-wire)
Protection category	IP65	IP65	IP66, 68; NEMA 4, 4X, 6
Process connections			
EN 1092-1	DN15...25	DN15...25	DN15...150
ASME B16.5	1/2...1"	1/2...1"	1/2...6"
Threaded	1/2...1" NPT, G1/2...G1	1/2...1" NPT, G1/2...G1	1/2...2" NPT, G1/2...G2
Special	Clamp, aseptic	Clamp, aseptic	Clamp, aseptic
Pressure ratings			
EN 1092-1	PN16, 40, 63, 100	PN16, 40, 63, 100	PN16, 40, 63, 100, 160, 250*
ASME B16.5	CL 150, 300, 600	CL 150, 300, 600	CL 150, 300, 600, 900, 1500, 2500*
Process pressure	0...145 bar/0...2102 psi	0...145 bar/0...2102 psi	0...400 bar/0...5802 psi, optional to 1000 bar/14500 psi
Measuring ranges			
Liquids	10...6300 l/h	10...6300 l/h	10...120000 l/h
Gases	0.7...220 m³/h	0.7...220 m³/h	0.7...2800 m³/h
Temperature ranges			
Process	-40...+200°C/-40...+362°F	-25...+200°C/-13...+362°F	-200...+300°C/-328...+572°F
Ambient non-Ex	-40...+70°C/-40...+128°F	-20...+70°C/-4...+128°F	-40...+120°C/-40...+248°F
Ambient Ex	-40...+60°C/-40...+140°F	-20...+60°C/-4...+140°F	-40...+65°C/-40...+149°F
Materials			
Wetted parts	Stainless steel	Stainless steel	Stainless steel, Hastelloy®, titanium, Monel®, ceramic, PTFE, Inconel®
Display	PPS or stainless steel	PPS or stainless steel	ATEX, IECEx, FM, NEPSI, CCOE/PESO, KCS, EAC, Inmetro
Approvals			
Ex	ATEX, IECEx, QPS, NEPSI	ATEX, IECEx, QPS, NEPSI	ATEX, IECEx, FM, NEPSI, CCOE/PESO, KCS, EAC, INMETRO
Sanitary and material approvals	NACE MR 0103/0175	NACE MR 0103/0175	FDA, EC 1935/2023, NACE MR 0103/0175





	For liquids and gases in hygienic processes	For acid and corrosive liquids and gases	For horizontal or upside down installation
	H250 F M40	H250 PTFE	H250 H
			
Measuring accuracy (VDI/VDE 3513)	1.6%	2.5%	2.5%
Outputs	4...20 mA	4...20 mA	4...20 mA
Limit switches	2	2	2
Totaliser	11 digit, pulse output	11 digit, pulse output	11 digit, pulse output
Communication	HART®, FF, PA	HART®, FF, PA	HART®, FF, PA
Power supply	12...30 VDC, (2-wire)	12...30 VDC, (2-wire)	12...30 VDC, (2-wire)
Protection category	IP66, 68, 69K; NEMA 4, 4X, 6	IP66, 68; NEMA 4, 4X, 6	IP66, 68; NEMA 4, 4X, 6
Process connections			
EN 1092-1	-	DN15...100	DN15...150
ASME B16.5	-	1/2...4"	1/2...6"
Threaded	DIN 11851, DIN 11864-1, SMS	-	1/2...2" NPT, G1/2...G2
Special	Clamp DIN 32626, ISO 2852, DIN 11864-3 or ASME BPE, aseptic flanges	-	Clamp, aseptic
Pressure ratings			
EN 1092-1	-	PN16, 40	PN16, 40, 63, 100, 160, 250*
ASME B16.5	-	CL 150, 300	CL 150, 300, 600, 900,
Process pressure	0...40 bar/0...580 psi	0...40 bar/0...580 psi	1500, 2500*
Measuring ranges			
Liquids	10...64000 l/h	25...60000 l/h	10...120000 l/h
Gases	0.7...1800 m³/h	1.8...350 m³/h	0.7...2800 m³/h
Temperature ranges			
Process	-200...+300°C/-328...+572°F	-80...+250°C/-112°F...+482°F	-200...+200°C/-328...+392°F
Ambient non-Ex	-40...+120°C/-40...+248°F	-40...+120°C/-40...+248°F	-40...+120°C/-40...+248°F
Ambient Ex	-40...+65°C/-40...+149°F	-40...+65°C/-40...+149°F	-40...+65°C/-40...+149°F
Materials			
Wetted parts	Stainless steel	PTFE, ceramics	Stainless steel, Hastelloy®
Display	Die cast aluminum, polyurethane coating or stainless steel	Die cast aluminum, polyurethane coating or stainless steel	Die cast aluminum, polyurethane coating or stainless steel
Approvals			
Ex	On request	ATEX, IECEx, FM, NEPSI, CCOE/ PESO, KCS, EAC, INMETRO	ATEX, IECEx, FM, NEPSI, CCOE/ PESO, KCS, EAC, INMETRO
Sanitary and material approvals	FDA, EC 1935/2023	FDA	NACE MR 0103/0175

*others on request

Metal devices

	For low liquid and gas flows, compact mechanical indicator, optional MIN/MAX switches and needle valve	For advanced low liquid and gas flows, mechanical	For advanced low liquid and gas flows, with electronic indicator
	DK32, 34	DK37 M8M	DK37 M8E
			
Measuring accuracy (VDI/VDE 3513)	4.0%	2.5%	2.5%
Outputs	-	-	4...20 mA
Limit switches	2	2	via HART®
Totaliser	-	-	via HART®
Communication	-	-	HART®
Power supply	-	-	14.8...30 VDC
Protection category	IP65	IP66	IP66
Process connections			
Connections	1/4" NPT, 1/2" NPT, G1/4, cutting clamp, clamping ring, hose connections*	1/4" NPT, 1/2" NPT, G1/4, cutting clamp, clamping ring, hose connections*	1/4" NPT, 1/2" NPT, G1/4, cutting clamp, clamping ring, hose connections*
Flange adapter	DN15, 25/1/2", 1"	DN15, 25/1/2", 1"	DN15, 25/1/2", 1"
Pressure ratings			
EN 1092-1	PN40, PN100*	PN40, PN100*	PN40, PN100*
ASME B16.5	CL 150, 300, 600, 1500, 2500	CL 150, 300, 600, 1500, 2500	CL 150, 300, 600, 1500, 2500
Process pressure	130 bar/1885 psi, optional to 400 bar/5800 psi	130 bar/1885 psi, optional to 400 bar/5800 psi	130 bar/1885 psi, optional to 400 bar/5800 psi
Measuring ranges			
Liquids	3...150 l/h	3...250 l/h	3...250 l/h
Gases	16...4800 l/h	16...8000 l/h	16...8000 l/h
Temperature ranges			
Process	-80...+150°C/-112...+302°F	-40...+150°C/-40...+302°F	-40...+150°C/-40...+302°F
Ambient non-Ex	-20...+70°C/-4...+128°F	-40...+70°C/-40...+128°F	-40...+70°C/-40...+128°F
Ambient Ex	-20...+60°C/-4...+140°F	-40...+60°C/-40...+140°F	-40...+60°C/-40...+140°F
Materials			
Wetted parts	Stainless steel, titanium, Monel®, Hastelloy®, Inconel®	Stainless steel, titanium, Monel®, Hastelloy®, Inconel®	Stainless steel, titanium, Monel®, Hastelloy®, Inconel®
Display	Die cast aluminum, polyurethane coating	PPS or stainless steel	PPS or stainless steel
Approvals			
Ex	ATEX, IECEx, FM, NEPSI, Inmetro	ATEX, IECEx, QPS, NEPSI, CCOE/PESO, EAC	ATEX, IECEx, QPS, NEPSI, CCOE/PESO, EAC
Sanitary and material approvals	NACE MR 0103/0175	NACE MR 0103/0175	NACE MR 0103/0175

Glass devices

	For low flow gas or liquid applications and sample flow monitoring	For basic applications	For low pressure gas applications	Plastic tube, for basic water applications
	DK46, 47, 48, 800	VA40	VA45	K20
				
Measuring accuracy (VDI/VDE 3513)	1.0%, 2.5%, 4.0%	1.0%	2.5%	±2.5% full scale
Outputs	-	4...20 mA	-	-
Limit switches	2	2	-	1
Totaliser	-	-	-	-
Communication	-	-	-	-
Power supply	-	14...30 VDC (2-wire)	-	-
Protection category	IP65	IP67	-	-
Process connections				
Connections	1/4" NPT, G1/4, cutting clamp, clamping ring, hose connections*	Threaded, flange, hose connections, hygienic design	Threaded, flange, hose connections	Threaded G1/2...2
Flange adapter	-	-	-	-
Pressure ratings				
EN 1092-1	-	PN40	-	-
ASME B16.5	-	CL 150	-	-
Process pressure	0...10 bar/0...145 psi	0...10 bar/0...145 psi	1 bar/14.5 psi	0...6 bar/0...72 psi
Measuring ranges				
Liquids	0.4...160 l/h	0.4...10000 l/h	-	0.65...25000 l/h
Gases	0.5...5000 l/h	0.007...310 m ³ /h	150...60000 l/h	-
Temperature ranges				
Process	-5...+100°C/-23...+212°F	-20...+100°C/-4...+212°F	-20...+100°C/-4...+212°F	-20...+100°C/-4...+212°F
Ambient non-Ex	-20...+100°C/-4...+212°F	-20...+100°C/-4...+212°F	-20...+100°C/-4...+212°F	-20...+100°C/-4...+212°F
Ambient Ex	-20...+70°C/-4...+128°F	-20...+85°C/-4...+185°F	-	-
Materials				
Measuring cone	Borosilicate glass	Borosilicate glass	Borosilicate glass	Polysulphone
Process connection	Stainless steel, brass, PVDF	Stainless steel, PVDF	Stainless steel	Polysulphone
Approvals				
Ex	ATEX, NEPSI, CCOE/PESO	ATEX	-	-
Sanitary and material approvals	FDA	FDA	-	-

*others on request

For liquids



OPTISONIC 3400
For process applications



OPTISONIC 3400 District Heating
For district heating applications



OPTISONIC 4400 HP
For high pressure liquids



OPTISONIC 4400 HT
For high temperature liquids

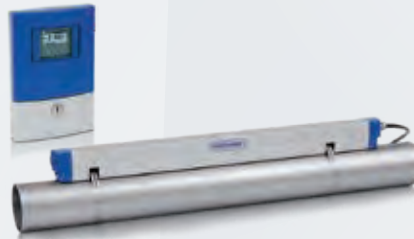

OPTISONIC 6300
Clamp-on flowmeter



OPTISONIC 6300 P
Portable clamp-on flowmeter

For gas and steam



OPTISONIC 7300
For natural gas, process gas
and utility gas applications



OPTISONIC 7300 Biogas
For biogas, landfill and
sewage gas applications



OPTISONIC 8300
For superheated steam and
high temperature gases

For custody transfer



ALTOSONIC III
For light liquid hydrocarbons



ALTOSONIC 5
For crudes, refined products, cryogenic media and chemicals



ALTOSONIC V LNG
For liquid hydrocarbons, including Liquefied Natural Gas (LNG)



ALTOSONIC V12
For custody transfer measurement of natural gas

Ultrasonic flowmeters



UFC 300 W

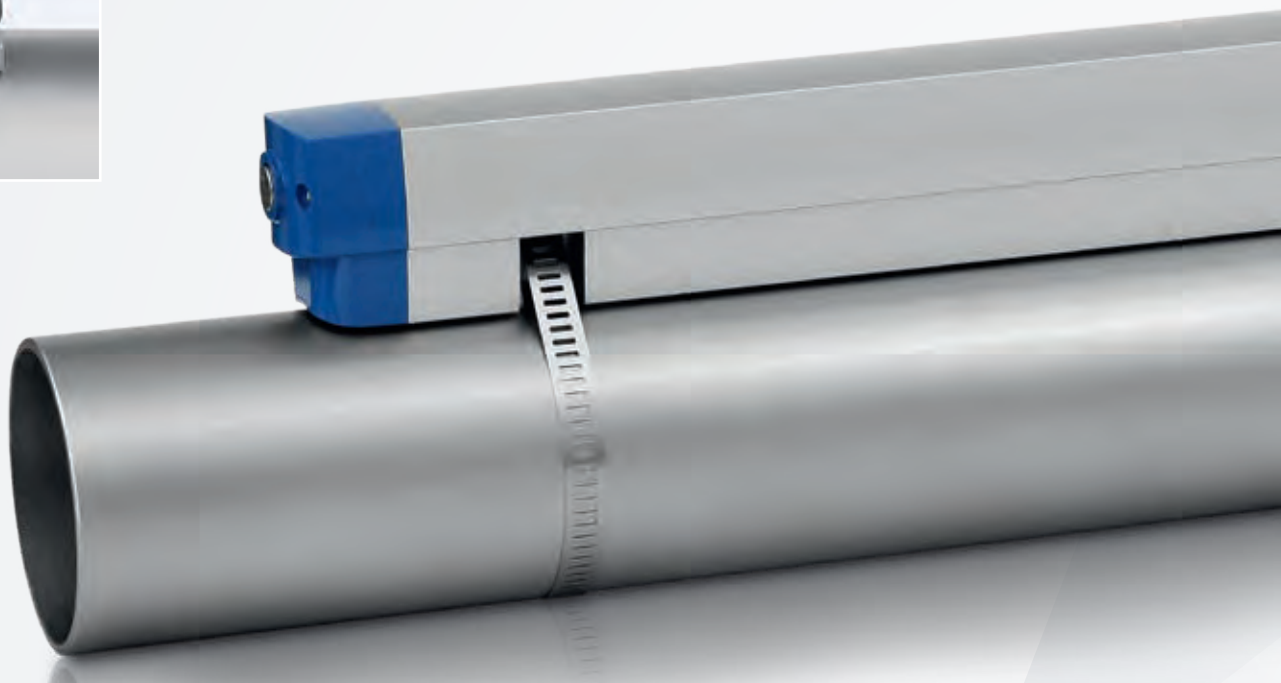

User-friendliness redefined

Ultrasonic clamp-on flowmeters: no training, no special tools, no open issues

Whether it's installation, commissioning, calibration or maintenance, KROHNE is the first manufacturer of ultrasonic clamp-on flowmeters to comprehensively deal with and redefine the topic of user-friendliness.

For the OPTISONIC 6300 ultrasonic flowmeter, for example, it takes just 15 minutes from installation to complete commissioning of the device.

This is due not only to the simple installation using patented clamping devices requiring no special tools but also to the signal measuring transducers pre-installed on the rail at the factory.

And commissioning the OPTISONIC 6300 is as simple as it is safe. After being switched on for the first time, the electronic unit carries out an automatic self test. The preset parameters cover 90 % of all applications.

An intelligent installation assistant now guides the user step by step through the program – and simultaneously provides support during optimisation of the flow measurement.

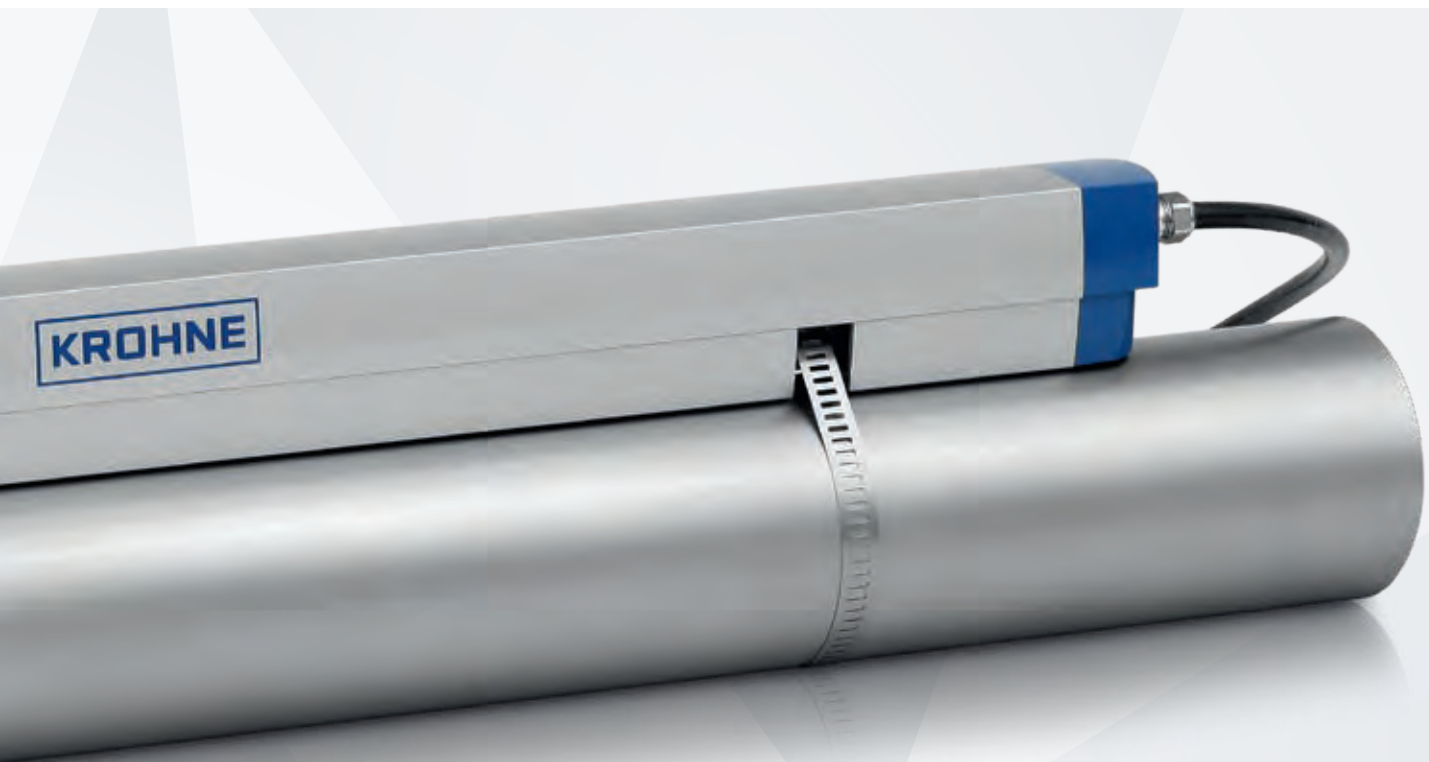

Ultrasonic flowmeters

Highlights:

- Complete portfolio for liquid, gas and steam applications
- Accuracy and reproducibility regardless of medium properties such as viscosity, temperature, density and electrical conductivity
- Diagnostic and compensation functions for disturbed flow profiles and deposits; NAMUR NE107 diagnostics
- No moving parts or components that protrude into the measuring tube
- Low operating and maintenance costs due to non-wearing parts
- Excellent long-term stability, no recalibration required
- High degree of reliability thanks to redundant measuring paths
- High-temperature versions available
- Large dynamic range
- Bi-directional flow measurement

The measuring principle

All KROHNE ultrasonic flowmeters are based on the transit time measurement principle. With this method, acoustic signals are transmitted and received along a diagonal measuring path. A sound wave going downstream with the flow travels faster than a sound wave going upstream against the flow. The difference in transit time is directly proportional to the mean flow velocity of the medium. Multiplied by the inner diameter of the pipe, the volumetric flow can be calculated. Through the use of multiple ultrasonic paths, flow profile disturbances are compensated for.

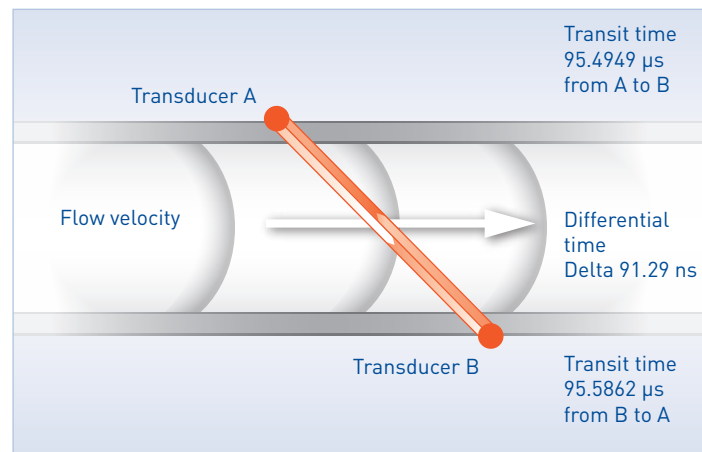

Standard in the process industry: Benchmark for custody transfer

In the early 1980's KROHNE started with the development of ultrasonic flowmeters which was the start of a continuous stream of innovative products.

In 1996, KROHNE introduced the ALTOSONIC V, the first high precision ultrasonic flowmeter for custody transfer measurement in the petroleum industry.

In 2003 the 3 path UFM 3030 was released, the first all-digital ultrasonic flowmeter. In 2008, KROHNE launched the ALTOSONIC V12, the first custody transfer flowmeter for natural gas certified to OIML R137 class 0.5.





Today KROHNE has a complete portfolio of ultrasonic flowmeters providing unparalleled performance and accuracy for a wide variety of applications in many different industries. Whether it's measuring cooling water and demineralized water in power plants, controlling dosing and mixing processes in the chemical industry or measuring liquid hydrocarbons in the oil and gas industry, you can put your absolute trust in KROHNE ultrasonic flowmeters in any situation.





Industries:



- Chemical
- Oil & Gas
- Petrochemical/Refineries
- Power Generation
- Water & Wastewater

For liquids

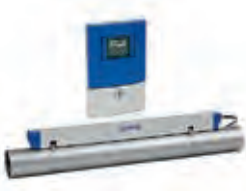

	For process applications	For district heating applications	For high temperature liquids	For high pressure liquids
	OPTISONIC 3400	OPTISONIC 3400 District Heating	OPTISONIC 4400 HT	OPTISONIC 4400 HP
				
Signal Converter	UFC 400	UFC 400	UFC 400	UFC 400
Measuring accuracy	3% ± 2 mm/s of m.v.	Class 1, 2 or 3	± 0,5% ± 5 mm/s of m.v.	± 1% ± 10 mm/s of m.v.
Process conditions	Liquids with max. 5% solid content and max. 2% gas content	Liquids with max. 5% solid content and max. 2% gas content	Liquids with max. 5% solid content and max. 2% gas content	Liquids with max. 5% solid content and max. 2% gas content
Power supply	100...240 VAC, 24 VAC/DC, 24 VDC	100...240 VAC	100...240 VAC, 24 VAC/DC, 24 VDC	100...240 VAC, 24 VAC/DC, 24 VDC
Inputs/Outputs	Current-, pulse-, status output and control input	Current-, pulse-, status output and control input	Current-, pulse-, status output and control input	Current-, pulse-, status output and control input
Communication	HART®, PROFIBUS® PA/DP, FF, Modbus RS485	HART®	HART®, Profibus® PA/DP, FF, Modbus RS485	HART®, Profibus® PA/DP, FF, Modbus RS485
Protection category	IP66, 67; NEMA 4X, 6	IP66, 67; NEMA 4X, 6	IP66, 67; NEMA 4X, 6	IP66, 67; NEMA 4X, 6
Measuring sensor	OPTISONIC 3000	OPTISONIC 3000	OPTISONIC 4000 HT	OPTISONIC 4000 HP
Sensor types	Standard, extended temperature, cryogenic, high viscosity	Standard	-	-
Diameter range	DN25...3000/1...120 inch	DN25...2000 / 1...80 inch	DN25...1000 / 1...40 inch	DN25...600 / 1...24 inch
Pressure range	EN1092-1: PN6...40 ASME B16.5: 150...900 lb	EN1092-1: PN6...40 ASME B16.5: 150...900 lb	ASME B16.5: 150...900 lb	ASME B16.5: 1500...2500 lb
Process temperature	-200...+250°C/-328...482°F	0...180°C/32...356°F	-45...+600°C/-49...+1112°F	-45...+180°C/-49...+356°F
Materials measuring sensor (wetted)	Stainless steel 1.4404 [AISI 316(L)], carbon steel	Stainless steel 1.4404 [AISI 316(L)], carbon steel	Carbon steel ASTM A106 gr B/A105N	Stainless steel 1.4404 [AISI 316(L)]
Protection category	IP67; NEMA 6	IP67; NEMA 6	IP67; NEMA 6	IP67; NEMA 6
Hazardous area approval	ATEX, IECEx, cQPSus, NEPSI, DNV, TIIS, PESO	ATEX	ATEX, IECEx, cQPSus, NEPSI, PESO	ATEX, IECEx, cQPSus, NEPSI, PESO

For gas and steam

Clamp-on flowmeter	Portable clamp-on flowmeter
OPTISONIC 6300	OPTISONIC 6300 P
	
UFC 300	UFC 300 P
± 1%	± 1%
Liquids with max. 5% solid content and max. 2% gas content	Liquids with max. 5% solid content and max. 2% gas content
100...240 VAC, 24 VAC/DC, 24 VDC	Battery powered
Current-, pulse-, status output and control input, 2x Current input	Current-, pulse-, status output
HART®, Modbus RS485	USB Slave
IP66, 67; NEMA 4X, 6	IP66, 67; NEMA 4X, 6
OPTISONIC 6000	OPTISONIC 6000 P
Small, medium, large, stainless steel, extended temperature	Small, medium
DN15...4000 / ½...160 inch	DN15...1500 / ½...60 inch
-	-
-40...+200°C/-40...+392°F	-40...+200°C/-40...+392°F
Aluminum, stainless steel	Aluminum, stainless steel
IP67, 68; NEMA 6, 6P	IP67; NEMA 6
ATEX, IECEx, cQPSus	-

For natural gas, process gas and utility gas applications	For biogas, landfill and sewage gas applications	For superheated steam and high temperature gases
OPTISONIC 7300	OPTISONIC 7300 Biogas	OPTISONIC 8300
		
GFC 300	GFC 300	GFC 300
± 1% of m.v.	± 1% of m.v.	± 1% of m.v.
Process gases with variable composition	Process gases with variable composition	Superheated steam
100...240 VAC, 24 VAC/DC, 24 VDC	100...240 VAC, 24 VAC/DC, 24 VDC	100...240 VAC, 24 VAC/DC, 24 VDC
Current-, pulse-, status output and control input, 2x Current input	Current-, pulse-, status output and control input, 2x Current input	Current-, pulse-, status output and control input, 2x Current input
HART®, FF, Modbus RS485	HART®, FF, Modbus RS485	HART®, FF, Modbus RS485
IP66, 67; NEMA 4X, 6	IP66, 67; NEMA 4X, 6	IP66, 67; NEMA 4X, 6
OPTISONIC 7000	OPTISONIC 7000 Biogas	OPTISONIC 8000
-	-	-
DN50...600/2...24 inch	DN50...600/2...24 inch	DN100...600/4...24 inch
EN1092-1: PN10...40 ASME B16.5: 150...900 lb	EN1092-1: PN10...40 ASME B16.5: 150...900 lb	ASME B16.5: 150...1500 lb
-40...+180°C/-40...+356°F	-40...+180°C/-40...+356°F	-25...620°C/-13...+1148°F
Stainless steel 1.4404 (AISI 316(L)), carbon steel	Stainless steel 1.4404 (AISI 316(L)), carbon steel	Carbon steel ASTM A106 gr B/A105N
IP67; NEMA 6	IP67; NEMA 6	IP67; NEMA 6
ATEX, IECEx, cQPSus	ATEX, IECEx, cQPSus	ATEX, IECEx, cQPSus

For custody transfer

	For light liquid hydrocarbons	For crudes, refined products, cryogenic media and chemicals
	ALTOSONIC III	ALTOSONIC 5
		
Signal converter	UFC III	UFC 5
Measuring accuracy	± 0.20% for Reynolds range > 10.000 ± 0.15%, for Reynolds range > 50.000	± 0.15%, No Reynolds limitation ± 0.10%, for Reynolds range > 10.000
Process conditions	Single products / light hydrocarbons, water content ≤ 10 %, Solids content < 5% (volume), air/gas content < 1% (volume)	Single- and multi products / light...heavy, crudes water content ≤ 10 %, Solids content < 5% (volume), air/gas content < 2% (volume)
Outputs	Current, pulse, status	Dual pulse, free configurable digital/analogue output
Inputs	Analogue 4..20 mA	Free configurable digital/analogue inputs
Communication	None	MODBUS, TCP/IP, USB
Power supply	24 V AC/DC (10 VA/10 W) 100...240 VAC (11 W)	24 VDC (28 W) 100 ... 240 VAC (35 W)
Protection category: Compact (C) Field (F) Wall (W)	IP66, IP67 - -	IP66 - -
Measuring sensor	UFS III	UFS 5
Process connections		
EN 1092-1	DN50...1000/PN10...PN40	DN100...1200/PN10...40
ASME B16.5	2...40"; 150...900 lbs	4...48"; 150...900 lbs
Temperature ranges		
Process	-200°C...+250°C/-328°F...+482°F	-200°C...+250°C/-328°F...+482°F
Ambient (incl. converter)	-40°C...+70°C/-40°F...+158°F	-55°C...+55°C/-67°F...+131°F
Materials		
Measuring tube, flange	Stainless steel	Stainless steel
Protection category		
Measuring sensor	IP66/67; NEMA 4X	IP66; NEMA 4X
Approvals		
Ex	ATEX, IECEx, DIV1	ATEX, IECEx, DIV1, EAC, NEPSI, INMETRO, CCoE
Custody transfer	OIML R117 class 0.3, MID MI-005, API, SIRIM	OIML R117 class 0.3, MID MI-005, API, INMETRO, SIRIM

	For custody transfer measurement of natural gas	For liquid hydrocarbons, including Liquefied Natural Gas (LNG)
	ALTOSONIC V12	ALTOSONIC V
		
Signal converter	GFC V12	UFC-V / UFP-V
Measuring accuracy	±0.2% of measured value, ±0.1% after linearisation	±0.15% of measured value, turndown ratio 1:10; ±0.20% of measured value, turndown ratio 1:50
Process conditions	Natural gas	Multi-hydrocarbons, viscosity 0.1...1500 cSt
Outputs	4 x digital	4 x digital, 1 x analogue
Inputs	Binary	6 x digital, 16 x analogue
Communication	Modbus 2 x RS485	Modbus RS422/485
Power supply	24 VDC	100...240 VAC; 24 VAC/DC
Protection category: Compact (C) Field (F) Wall (W)	IP66; NEMA X4 - -	IP65, 67; NEMA 4, 6 - -
Measuring sensor	ALTOSONIC V12	ALTOSONIC V
Process connections		
EN 1092-1	DN100...600	DN100...600
ASME B16.5	4...64"; CL 150...2500	4...40"; CL 150...1500
Temperature ranges		
Process	-40...+100°C/-40...+212°F	-200...+250°C/-328...+428°F
Ambient (incl. converter)	-40...+65°C/-40...+149°F	-55...+60°C/-67...+140°F
Materials		
Measuring tube, flange	LT carbon steel, stainless steel and duplex optional	Steel, stainless steel, Hastelloy® C4, duplex
Protection category		
Measuring sensor	IP66; NEMA 4X	IP65, 67; NEMA 4, 6
Approvals		
Ex	ATEX, FM, CSA, IECEx, EAC RU	ATEX, FM, CSA,
Custody transfer	OIML R137 class 0.5, MID, AGA 9, ISO 17089	MID MI-005, Gosstandard, OIML R-117-1 class 0.3, API

The modular product line

Converters



MFC 400 C
General purpose



MFC 400 F
Field housing



MFC 010
Modbus converter for economical OEM system integration

Flow sensors



OPTIMASS 1000
For universal applications and process control

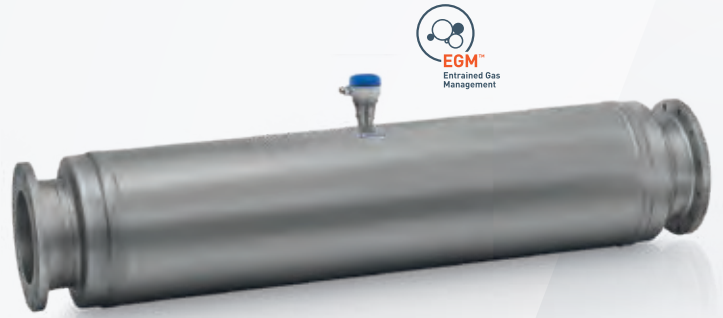

OPTIMASS 2000
Dual or four straight tube design for bulk flows for custody transfer up to DN400/16"



OPTIMASS 3000
For low flow and dosing applications



OPTIMASS 7000
For advanced applications, with single straight measuring tube



OPTIMASS 6000
The standard high-performance meter
for the process industry, up to DN300/12"

The specialists



OPTIGAS 4010
Specially designed for CNG and
LPG in dispensing systems



OPTIBATCH 4011
Specially designed for linear
and rotating filling machines

Accessories



OPTICHECK
Service tool for in-situ verification
of field devices

Mass flowmeters

Mass flowmeters: A solution for all process applications

When it comes to selecting a flowmeter for your application, the OPTIMASS range covers all bases. Our engineers have developed a family of meters from small to large, for high pressure, cryogenic temperatures and high temperatures.

All meters have been designed to reduce constraints on the user with regards to installation – simply follow good engineering practice to obtain the desired results. Another highlight is the diagnostics platform, which is unique in this class of device. It not only monitors the device itself but also the process environment.

Within the system, the diagnostics software monitors the process temperature and a series of auxiliary values such as the driver energy, in order to ultimately confirm the condition of the process medium. OPTIMASS can even generate intelligent warning messages when a certain proportion of gas bubbles or solids is exceeded, providing valuable information about the process itself.



Highlights:

- Entrained Gas Management EGM: no loss of measurement with gas entrainments up to 100%
- Indication or configurable alarm to improve processes by identifying transient gas entrainments
- Not susceptible to installation effects: can be installed regardless of type of installation (no straight inlets/outlets) and external influences such as tube vibrations
- Only straight tube measuring devices for custody transfer applications in the highest OIML accuracy class of 0.3, approved to OIML R117/MID
- Flow rates from 0.0003 to 4,600 t/h
- 4-wire, 3 x 4...20 mA, HART®, Modbus, FF, PROFIBUS®-PA/DP, PROFINET etc.
- Minimal pressure loss with straight tube measuring devices: reduced power consumption of pumps
- High density accuracy, not affected by medium and temperature changes
- Suitable for highly viscous media, inhomogeneous mixtures, media with solid content or gas inclusions
- Modular design for quick and easy replacement of electronics and/or flow sensors
- Self-draining and easy to clean
- OPTIMASS 7000 suitable for highly sensitive media as well as media requiring low flow velocity
- Variety of wetted materials (e.g. for corrosive media): titanium, stainless steel, HASTELLOY®, tantalum, duplex & super duplex
- Options for secondary containment up to 100 bar/1450 psi (OPTIMASS 2000 up to 150 bar/2176 psi)
- Turnkey solutions for the operation of batch plants

Mass flowmeters

The measuring principle

Mass flowmeters work on the Coriolis principle. The mass flow rate of liquids and gases can be calculated from the deformation of the measuring tube caused by the flow. The media density can also be derived from the resonance frequency of the oscillating tube. Two sensor coils are used to calculate the Coriolis effect. If there is no flow, both sensors record the same sinusoidal signal. Once the flow begins, the Coriolis force acts on the flowing mass particles of the medium and causes the measuring tube to deform, resulting in a phase shift between the sensor signals. The sensors measure the phase shift of the sinusoidal vibrations. This phase shift is directly proportional to the mass flow rate.

Diagram of OPTIMASS 1000

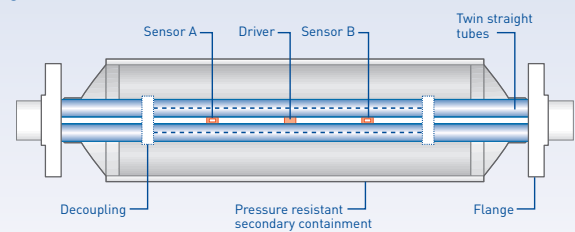

Sympathetic vibration without flow*

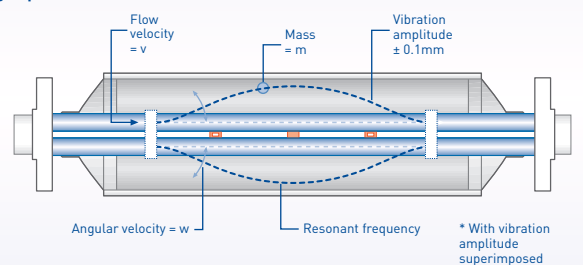

Phase shift with flow*

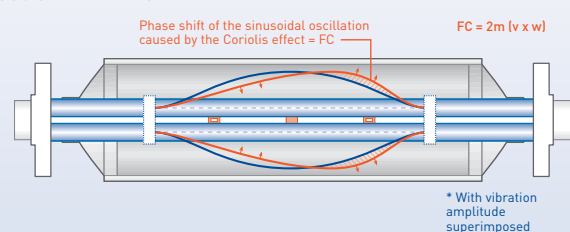

Superior performance – Even with quick temperature and media changes

Just how accurate and reliable a mass flowmeter actually is becomes obvious when constant parameters such as medium, temperature or pressure undergo sudden changes. The OPTIMASS series from KROHNE sets the standard. With high performance straight and bent tube designs.

KROHNE offers superior straight and bent tube design mass flowmeters, so the customer now can choose the best meter for their application. We offer a unique straight tube design for minimal pressure drop, highly viscous and slurry applications. The superior bent tube design is suitable for cryogenic, high temperature applications and extremely high pressures.

The MFC 400 converter offers excellent zero stability, advanced density and concentration measurement and a high performance with air entrainment. With new Entrained Gas Management™ the meter is now able to measure from 0 % to 100 % gas entrainment.

Industries:

- Chemical
- Pharmaceutical
- Food & Beverage
- Oil & Gas
- Petrochemical
- Pulp & Paper
- Metal & Mining
- Power Generation
- Water & Wastewater
- Marine

OPTIMASS 2400 – Minimal installation footprint

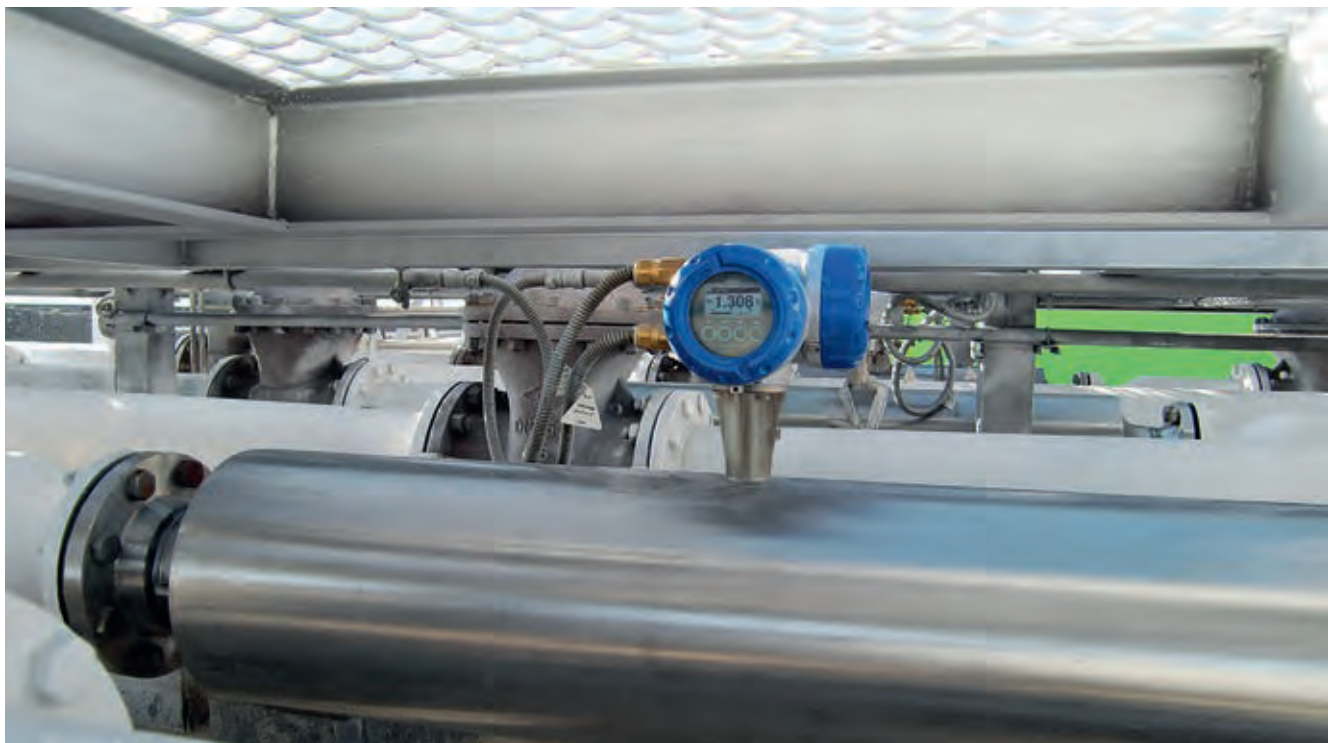



The modular product line

	For universal applications and process control	Dual or four straight tube design for bulk flows for custody transfer up to DN400/16"	For low flow and dosing applications
	OPTIMASS 1010		OPTIMASS 3010
Measuring accuracy	Liquid: $\pm 0.15\%$ Gas: 0.35% Density: $\pm 2 \text{ kg/m}^3$	-	Liquid: $\pm 0.1\%$ Gas: $\pm 0.5\%$ Density: $\pm 2 \text{ kg/m}^3$ ($\pm 0.5 \text{ kg/m}^3$)
Communication	Modbus	-	Modbus
Power supply	12 VDC	-	12 VDC
Protection category	IP67; NEMA 4X	-	IP67; NEMA 4X
	OPTIMASS 1400	OPTIMASS 2400	OPTIMASS 3400
			
	OPTIMASS 1000 + MFC 400	OPTIMASS 2000 + MFC 400	OPTIMASS 3000 + MFC 400
Measuring accuracy	Liquid: $\pm 0.15\%$ Gas: 0.35% Density: $\pm 2 \text{ kg/m}^3$	Liquid: $\leq 0.1\%$ (optional: $\pm 0.05\%$) Gas: $\leq 0.35\%$ Density: $\pm 1 \text{ kg/m}^3$ ($\pm 0.2 \text{ kg/m}^3$)	Liquid: $\pm 0.1\%$ Gas: $\pm 0.5\%$ Density: $\pm 2 \text{ kg/m}^3$ ($\pm 0.5 \text{ kg/m}^3$)
Outputs	Current, pulse/frequency, status	Current, pulse/frequency, status	Current, pulse/frequency, status
Inputs	Binary	Binary	Binary
Communication	HART®, FF, PA, DP, Modbus, PROFINET®	HART®, FF, PA, DP, Modbus, PROFINET®	HART®, FF, PA, DP, Modbus, PROFINET®
Power supply	85...250 VAC; 11...31 VDC; 20.5...26 VAC/DC	85...250 VAC; 11...31 VDC; 20.5...26 VAC/DC	85...250 VAC; 11...31 VDC; 20.5...26 VAC/DC
Protection category: Compact (C) Field (F) Wall (W) Rack (R)	IP66, 67; NEMA 4, 4X, 6 IP66, 67; NEMA 4, 4X, 6 IP65; NEMA 4, 4X IP20; NEMA 1	IP66, 67; NEMA 4, 4X, 6 IP66, 67; NEMA 4, 4X, 6 IP65; NEMA 4, 4X IP20; NEMA 1	IP66, 67; NEMA 4, 4X, 6 IP66, 67; NEMA 4, 4X, 6 IP65; NEMA 4, 4X IP20; NEMA 1
Measuring sensor	OPTIMASS 1000	OPTIMASS 2000	OPTIMASS 3000
			
	OPTIMASS 1000	OPTIMASS 2000	OPTIMASS 3000
Nominal sizes			
Device, EN 1092-1	DN15...50	DN100...400	DN1...4
Connection EN 1092-1	DN15...100	DN100...400	DN15
Device, ASME B16.5	1/2...2"	4...16"	1/25...4/25"
Connection ASME B16.5	1/2...4"	4...16"	1/2"
Screw-on connector NPT	-	-	1/4" (up to 300 bar; 4351 psi)
Pressure rating EN 1092-1	PN40, 63, 100	PN16, 40, 63, 100, 160	PN40, 63
Pressure rating ASME B16.5	CL 150, 300, 600	CL 150, 300, 600, 900, 1500	CL 150, 300, 600
Secondary pressure containment	100 bar/1450 psi	40 bar/580 psi (opt. 150 bar/ 2175 psi)	30 bar/435 psi
Measuring ranges	48...170000 kg/h	1560...4600000 kg/h	0.3...450 kg/h
Process temperature	-40...+130°C/-40...+266°F	-40...+130°C/-49...+266°F	-40...150°C/-40...+300°F
Ambient temperature	-40...+65°C/-40...+149°F	-40...+65°C/-40...+149°F	-40...65°C/-40...+149°F
Sensor materials	Stainless steel	Stainless steel, duplex, super duplex	Stainless steel, Hastelloy® C22
Protection category sensor	IP67; NEMA 4X	IP67; NEMA 4X	IP67; NEMA 4X
Ex-Approvals	ATEX, FM, CSA, NEPSI, IECEx	ATEX, FM, CSA, NEPSI, IECEx	ATEX, FM, CSA, NEPSI
Sanitary & material approvals	3A, EHEDG	NACE	NACE
Custody transfer	-	OIML R117, Inmetro, NTEP, MI 005, MI 002	-
Functional Safety	-	-	-

The specialists

The standard high-performance meter for the process industry, up to DN300/12"	For advanced applications, with single straight measuring tube
	OPTIMASS 7010
-	Liquid: $\pm 0.1\%$ Gas: 0.35% Density: $\pm 2 \text{ kg/m}^3$ ($\pm 0.5 \text{ kg/m}^3$)
-	Modbus
-	12 VDC
-	IP67; NEMA 4X
OPTIMASS 6400	OPTIMASS 7400
	
OPTIMASS 6000 + MFC 400	OPTIMASS 7000 + MFC 400
Liquid: $\pm 0.1\%$, $\pm 0.05\%$ optional Gas: 0.35% Density: $\pm 1 \text{ kg/m}^3$ ($\pm 0.2 \text{ kg/m}^3$)	Liquid: $\pm 0.1\%$ Gas: 0.35% Density: $\pm 2 \text{ kg/m}^3$ ($\pm 0.5 \text{ kg/m}^3$)
Current, pulse/frequency, status	Current, pulse/frequency, status
Binary	Binary
HART®, FF, PA, DP, Modbus, PROFINET®	HART®, FF, PA, DP, Modbus, PROFINET®
85...250 VAC; 11...31 VDC; 20.5...26 VAC/DC	85...250 VAC; 11...31 VDC; 20.5...26 VAC/DC
IP66, 67; NEMA 4, 4X, 6 IP66, 67; NEMA 4, 4X, 6 IP65; NEMA 4, 4X IP20; NEMA 1	IP66, 67; NEMA 4, 4X, 6 IP66, 67; NEMA 4, 4X, 6 IP65; NEMA 4, 4X IP20; NEMA 1
OPTIMASS 6000	OPTIMASS 7000
	
OPTIMASS 6000	OPTIMASS 7000
DN8...250	DN6...80
DN10...250	DN10...100
1/2...10"	1/4...3"
1/2...10"	1/2...4"
-	-
PN16, 40, 63, 100, 160	PN40, 63, 100
CL 150, 300, 600, 900, 1500	CL 150, 300, 600
-	100 bar; 1450 psi
5...1500000 kg/h	9.5...560000 kg/h
-200...+400°C/-328...752°F	-40...+150°C/-40...+302°F
-40...+65°C/-40...+149°F	-40...+65°C/-40...+149°F
Stainless steel, Hastelloy® C22, duplex steel	Stainless steel, Hastelloy® C22, titanium, tantalum
IP67; NEMA 4X	IP67; NEMA 4X
ATEX, cFMus, IECEx, NEPSI	ATEX, FM, CSA, NEPSI, IECEx
3A, EHEDG, NACE	EHEDG, 3A, ASME Bioprocessing
OIML R117, OIML R137, Inmetro, NTEP, MI 005, MI 002	OIML R117, Inmetro, NTEP, MI 005
SIL2/3	-

Specially designed for linear and rotating filling machines	Specially designed for CNG and LPG in dispensing systems
OPTIBATCH 4011	OPTIGAS 4010
Liquid: Mass: $\pm 0.15\%$ Volume: $\pm 0.2\%$	Liquid: $\pm 0.5\%$ per batch Gas: $\pm 0.5\%$ per batch
Modbus (configuration)	Modbus
24 VDC	12 VDC
IP67; NEMA 6	IP67; NEMA 4X
OPTIBATCH 4011	OPTIGAS 4010
	
Liquid: Mass: $\pm 0.15\%$ Volume: $\pm 0.2\%$	Liquid: $\pm 0.5\%$ per batch Gas: $\pm 0.5\%$ per batch
Pulse/frequency	-
-	-
Modbus (configuration)	Modbus
24 VDC	12 VDC
IP67; NEMA 6	IP67; NEMA 4X
-	-
-	-
-	-
OPTIBATCH 4000	OPTIGAS 4000
	
DN8...15	DN15
-	-
-	1/2"
-	-
-	3/4"
Process pressure: 10 bar/145 psi	Process pressure: 350 bar/ 5076 psi static; 300 bar/ 4351 psi cyclical
-	-
6...4320 kg/h	60...4200 kg/h
0...+100°C/+32...+212°F	-40...+93°C/-40...+200°F
-40...+55°C/-40...+131°F	-40...+55°C/-40...+131°F
Stainless steel	Stainless steel
IP67; NEMA 4X	IP67; NEMA 4X
-	ATEX, NEPSI
3A, ASME Bioprocessing, EHEDG	-
-	PTB, OIML R139 (pending)
-	-



OPTISWIRL 4200 C flange
For utility applications and energy
management systems



OPTISWIRL 4200 C sandwich
All advantages of the OPTISWIRL 4200
in a space-saving sandwich design;
centering rings guarantee an easy
installation without any offset



OPTISWIRL 4200 F flange
OPTISWIRL 4200 F sandwich
Remote version with field housing
converter with connection cable
up to 50 m/164 ft



OPTISWIRL 4200 Dual version
With two independent measuring sensors and two signal converters for multiproduct pipelines, redundant measurement and increased safety demands



OPTISWIRL 4200 C 1R / 2R
With integrated nominal diameter reduction for space-saving and cost-saving installations

Accessories



OPTICHECK
Service tool for in-situ verification of field devices



Stainless steel centering rings for easy mounting

Vortex flowmeters

Highlights:

- Integrated pressure and temperature compensation for fluctuating pressures and temperatures
- Temperature compensation for saturated steam is a standard feature
- All devices feature 2-wire technology
- Excellent long-term stability thanks to sturdy construction
- High measuring accuracy
- Maintenance-free sensor
- Non-wearing, fully-welded stainless steel construction with high resistance to corrosion, pressure and temperature
- OPTISWIRL 4070: Intelligent Signal Processing (ISP) ensures maximum measurement reliability and stability
- OPTISWIRL 4200: Advanced Vortex Frequency Detection (AVFD) – state-of-the-art technology for digital signal filtering
- Instantly ready for operation (plug & play)
- SIL2 certified
- Use in hazardous areas
- Dual version for redundant measurement and multiproduct pipelines
- Integrated reduction of nominal diameter for space-saving installation and large measuring spans
- Redundant Data Management: Easy exchange of electronics without loss of calibration and parametrisation data
- FAD (Free Air Delivery) functionality
- Gross and net heat calculation to support advanced energy management

Vortex flowmeters

The measuring principle

The function of vortex flowmeters is based on the principle of the Karman vortex street: Opposing vortices form behind an object in a stream. The measuring tube contains a bluff body, behind which vortex shedding occurs. The frequency of the vortex shedding is proportional to the flow rate. The shedded vortices are picked up and counted as pressure surges by a piezo crystal in the sensor.

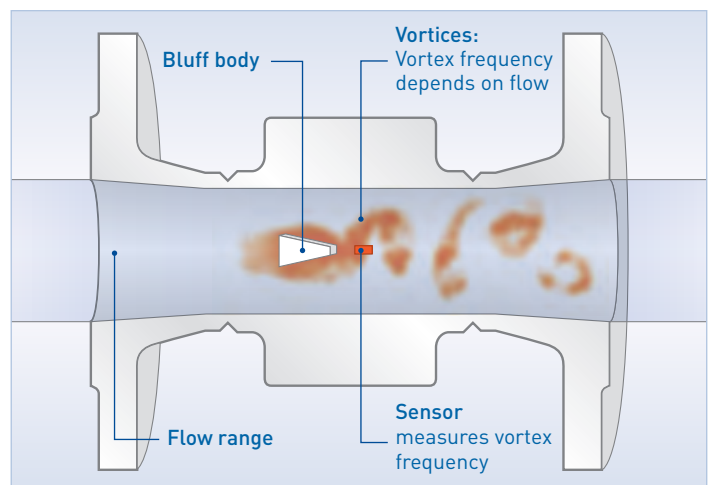

Allrounder with integrated pressure and temperature compensation

Vortex flowmeters are suitable for a wide range of media. This is particularly true of the KROHNE OPTISWIRL: It measures both conducting and non-conducting liquids as well as all industrial gases. It also measures saturated steam and superheated steam, compressed air and nitrogen, liquefied gas and flue gas, demineralized water and boiler feed water, solvents and heat transfer oil.

The KROHNE OPTISWIRL even masters fluctuating pressures and temperatures thanks to integrated pressure and temperature compensation.

The collection of the volume flow and the process data at only one point ensures accurate density compensation and combines high system accuracy with low investment costs. Internal gross and net heat calculation complete the device to be a reliable partner for advanced energy management.



Highest reliability and lowest probability of failure: The new OPTISWIRL 4200 was designed for safety related applications right from the start. Both its hardware and its software are developed to meet the strict requirements of SIL 2 safety functions: On demand as well as continuously!

Industries:

- Chemical
- Metal & Mining
- Power Generation
- Oil & Gas
- Petrochemical
- Pulp & Paper
- Food & Beverage
- Water & Wastewater



Vortex flowmeters

	For utility applications and energy management systems	All advantages of the OPTISWIRL 4200 in a space-saving sandwich design; centering rings guarantee an easy installation without any offset
	OPTISWIRL 4200 C/F flange	OPTISWIRL 4200 C/F sandwich
		
Signal converter	VFC 200 C/F	VFC 200 C/F
Measuring accuracy	Re > 20000 ±0.75% for liquids Re > 20000 ±1% for gases and steam 10000 < Re < 20000 ±2% for liquids, gases and steam	Re > 20000 ±0.75% for liquids Re > 20000 ±1% for gases and steam 10000 < Re < 20000 ±2% for liquids, gases and steam
Repeatability	±0.1%	±0.1%
Product temperature	-40...+240°C/-40...+464°F	-40...+240°C/-40...+464°F
Outputs	mA, pulse/frequency/status/limit switch	mA, pulse/frequency/status/limit switch
Input	mA	mA
Communication	HART®, PA, FF	HART®, PA, FF
Power supply (Non Ex)	12...30 VDC	12...30 VDC
Power supply (Ex)	12...36 VDC	12...36 VDC
Protection category	IP66, 67, optional IP66, 68	IP66, 67, optional IP66, 68
Housing material	Aluminum, stainless steel	Aluminum, stainless steel
Functionality		
FAD	FAD	FAD
Gross and net heat calculation	Gross and net heat	Gross and net heat
Measuring sensor	VFM 4000 flange	VFM 4000 sandwich
Process connections		
EN 1092-1	DN15...300; PN16, 25, 40, 63, 100	DN15...100; PN16, 25, 40, 63, 100
ASME B16.5	1/2...12"; CL 150, 300, 600, 900, 1500	1/2...4"; CL 150, 300, 600
Temperature ranges		
Process	-40...+240°C/-40...+464°F	-40...+240°C/-40...+464°F
Ambient (Non Ex)	-40...+85°C/-40...+185°F	-40...+85°C/-40...+185°F
Ambient (Ex)	-40...+65°C/-40...+149°F	-40...+65°C/-40...+149°F
Materials		
Measuring sensor	1.4404/316L, Hastelloy® C22	1.4404/316L, Hastelloy® C22
Sensor seal	1.4435/316L, Hastelloy® C276	1.4435/316L, Hastelloy® C276
Protection category		
Measuring sensor	IP66, 67	IP66, 67
Reduction of nominal diameter		
Measuring sensor	1 or 2 steps reduced bore meter	-
Approvals		
Ex	ATEX, FM (USA and Canada), IECEx	ATEX, FM (USA and Canada), IECEx
Functional Safety	SIL2	SIL2

	With two independent measuring sensors and two signal converters multiproduct pipelines, redundant measurement and increased safety demands
	OPTISWIRL 4200 Dual version
	
Signal converter	VFC 200
Measuring accuracy	Re > 20000 ±0.75% for liquids Re > 20000 ±1% for gases and steam 10000 < Re < 20000 ±2% for liquids, gases and steam
Repeatability	±0.1%
Product temperature	-40...+240°C/-40...+464°F
Outputs	mA, pulse/frequency/status/limit switch
Input	mA
Communication	HART®, PA, FF
Power supply (Non Ex)	12...30 VDC
Power supply (Ex)	12...36 VDC
Protection category	IP66, 67, optional IP66, 68
Housing material	Aluminum, stainless steel
Functionality	
FAD	FAD
Gross and net heat calculation	Gross and net heat
Measuring sensor	
Process connections	
EN 1092-1	DN25...100; PN16, 25, 40, 63, 100
ASME B16.5	1...4"; CL 150, 300, 600, 900, 1500
Temperature ranges	
Process	-40...+240°C/-40...+464°F
Ambient (Non Ex)	-40...+85°C/-40...+185°F
Ambient (Ex)	-40...+65°C/-40...+149°F
Materials	
Measuring sensor	1.4404/316L, Hastelloy® C22
Sensor seal	1.4435/316L, Hastelloy® C276
Protection category	
Measuring sensor	IP66, 67
Reduction of nominal diameter	
Measuring sensor	1 or 2 steps reduced bore meter
Approvals	
Ex	ATEX, FM (USA and Canada), IECEx
Functional Safety	SIL2

Pressure transmitters



OPTIBAR DP 7060
Differential pressure transmitter for flow applications, with integrated absolute pressure measurement

Primary flow elements

Orifice plates



OPTIBAR OP 1100/1110
Raised face (RF) or ring type joined (RTJ) designs



OPTIBAR OP 3100/3200
With flat sealing face and corner taps



OPTIBAR OP 4100
With annular chamber and corner taps



OPTIBAR OP 5100/5110
Assembly with measuring flanges (ASME 16.36)

Averaging pitot tubes



OPTIBAR PT 2000
With multiple impact-sensing ports



Other flow elements such as venturis, nozzels, cone and wedge meters facc. to ISO or ASME standards available on request.

Meter runs

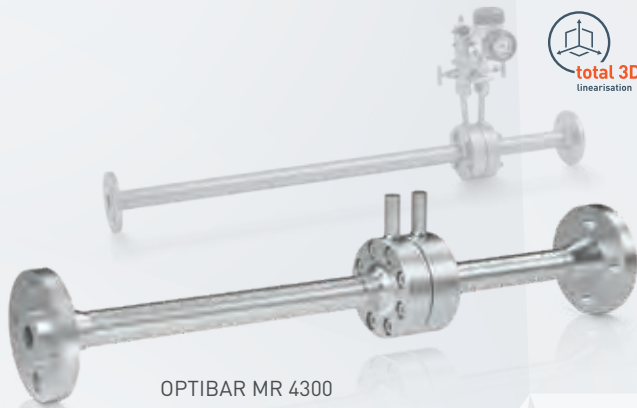

OPTIBAR MR 4300
Orifice meter run assembly with corner
taps and annular chambers

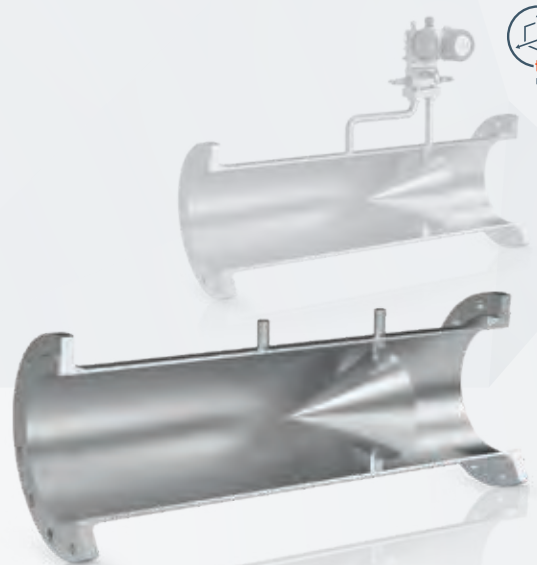

OPTIBAR MR 6300
Cone meter run with single taps

Accessories



Accessories for safe and easy installation of
pressure transmitters in the process:

- Manometer and barstock valves, 3-/5-way valve manifolds, also for steam and high temperature applications
- Condensate pots for steam applications
- Fittings, seals, blind-plugs, oval flange adapter and gauge snubber

Differential pressure flow measurement

Differential pressure flow measurement

The measuring principle

For over 100 years, the process industry has used the Differential Pressure (DP) flow measurement method to determine the volume or mass flow of liquids, gases and steam in commercial use.

With DP, pressure is measured at two points across a restriction in the line – for example, a primary element. Using the Bernoulli equation, the difference in pressure between these two points indicates flow velocity and, because the pipe size is known, a volume flow rate can be calculated.

Today, DP is being constantly improved and adapted to meet the requirements of modern processes, and KROHNE is helping to lead the way.

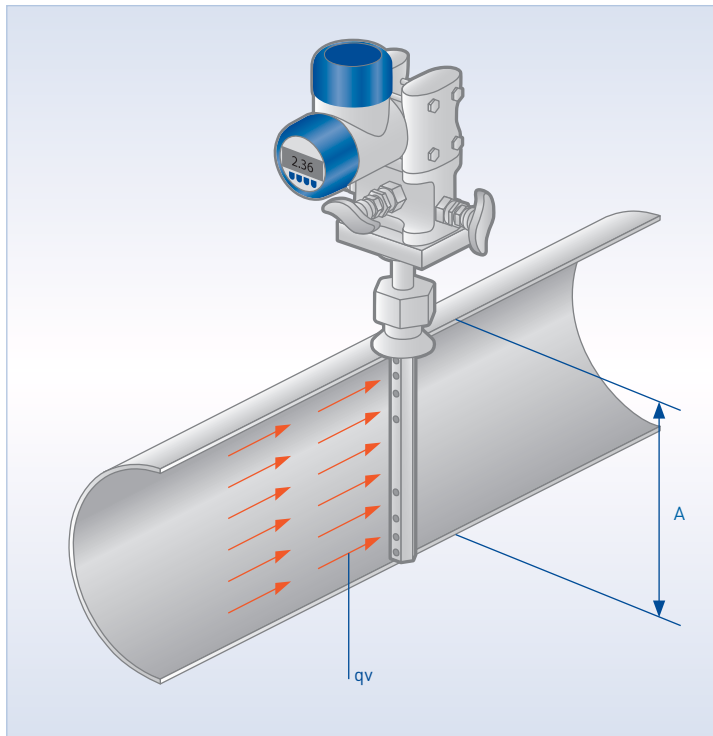

Pitot tube

As an alternative to orifice plates, the pitot tube provides a simple, cost-efficient and long-term stable flow measurement solution for:

- Applications that require a low pressure loss
- Retrofitting of existing pipelines with flow measurement
- Line sizes >DN 300/12"
- Low pressure gases

A pitot tube consisting of two chambers is placed in the pipe transversely to the direction of the flow. An upstream chamber faces the flow and a downstream chamber is placed at the back of the probe.

The impact of the medium against the upstream chamber causes an overpressure that adds to the static pressure in the pipe. Depending on its shape, a negative pressure builds up in the downstream chamber. Both pressures are transmitted to a differential pressure transmitter that converts the difference between the two chambers into an output signal.

Flow velocity is calculated using the differential pressure and medium density $v = k \times \sqrt{2 \times \Delta p / \rho}$. Volume flow is calculated from the flow velocity and the crosssection area $qv = v \times A$.

Orifice plates

Orifice plates work by restricting the flow of the liquid, gas or steam being monitored. According to the Bernoulli equation, the flow velocity increases at the restriction, and the static pressure drops. The difference in pressure at the measuring point is a measure for the flow velocity of the medium.

Volume flow is calculated from the flow velocity and the cross-section area: $qv = v \times A$

The diameter ratio $\beta = d/D$ is determined for each measuring point, allowing each one to be optimised for specific requirements, including shorter inlet/outlet runs, lower pressure losses and in some instances smaller overall uncertainty.

Orifice plate primary elements are worldwide standardised according to ISO 5167.

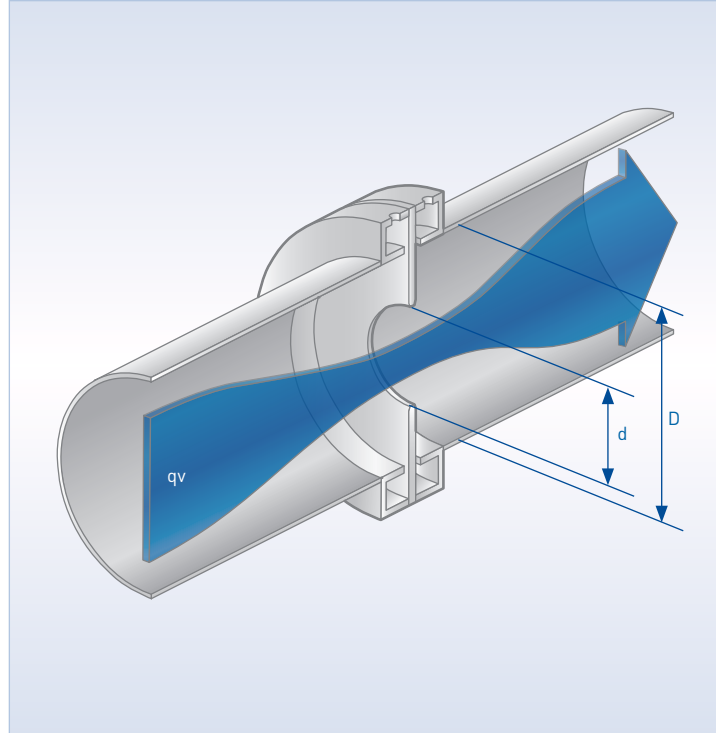

Highlights:

- Worldwide standardised flow measurement principle according to ISO 5167
- All measurement uncertainties under operational conditions are known and can be calculated
- Volume or mass flow measurement of liquids, gases or steam
- Medium temperatures -200...+1000°C / -328...1832°F
- Process pressure up to 400 bar / 5800 psi
- Line sizes from DN25...12000 / 1...470"
- One pressure transmitter for all flow applications, compact or remote version
- Integrated absolute pressure measurement
- Pressure and temperature compensation available as option
- Wet-calibrated meter runs for small line sizes and low measurement uncertainty
- Optimisation of measuring points according to a given specification, e.g. short inlet/outlet, low pressure loss, small overall uncertainty, etc.
- Change of pressure transmitter without process interruption
- Compliant to PED 97/23/EC with CE marking
- Large choice of materials for corrosive and non-corrosive mediums
- 4...20 mA HART® 7 / HART® SIL2/3, FOUNDATION™ fieldbus, PROFIBUS® PA as communication options

Introducing OPTIBAR differential pressure flow measurement products

Today, in over 40 % of all flow applications, differential pressure meters are still the first choice. With the release of the OPTIBAR series, KROHNE is extending its process instrumentation portfolio to meet this demand.

The range includes a variety of modular transmitters, application specific diaphragm seals, primary elements, accessories, valves and manifolds. This offers you the option to buy, from one source, single DP pressure transmitters as well as complete DP flow measuring points, with matched, preconfigured components, (wet) calibrated and ready to install.



Modular design concept

Complete measuring points

KROHNE will provide you with all necessary instruments for your flow measurement point: from primary elements, up to a flow computer for gas, liquid and steam calculations.

For measurement uncertainties due to changing process conditions, the flow computer holds appropriate algorithms for all primary elements. By adding temperature and pressure sensors, density compensation or gross and net energy calculations are also possible.

When commissioning a complete measuring point from us, investment costs like primary element design, component assembly up to pre-parametrisation of the differential pressure transmitter and flow computer are all less. And there are no additional costs for piping, installation and testing at the measuring point.

KROHNE's approach to design also guarantees that up to 70 % of potential leakage points will be eliminated, cutting service and maintenance costs.

Industries:

- Oil & Gas
- Chemical
- Petrochemical
- Heating, Ventilation and Air Conditioning (HVAC)
- Power Generation
- Metal & Mining
- Food & Beverage

Complete DP flow measuring point for compensated volume/mass flow

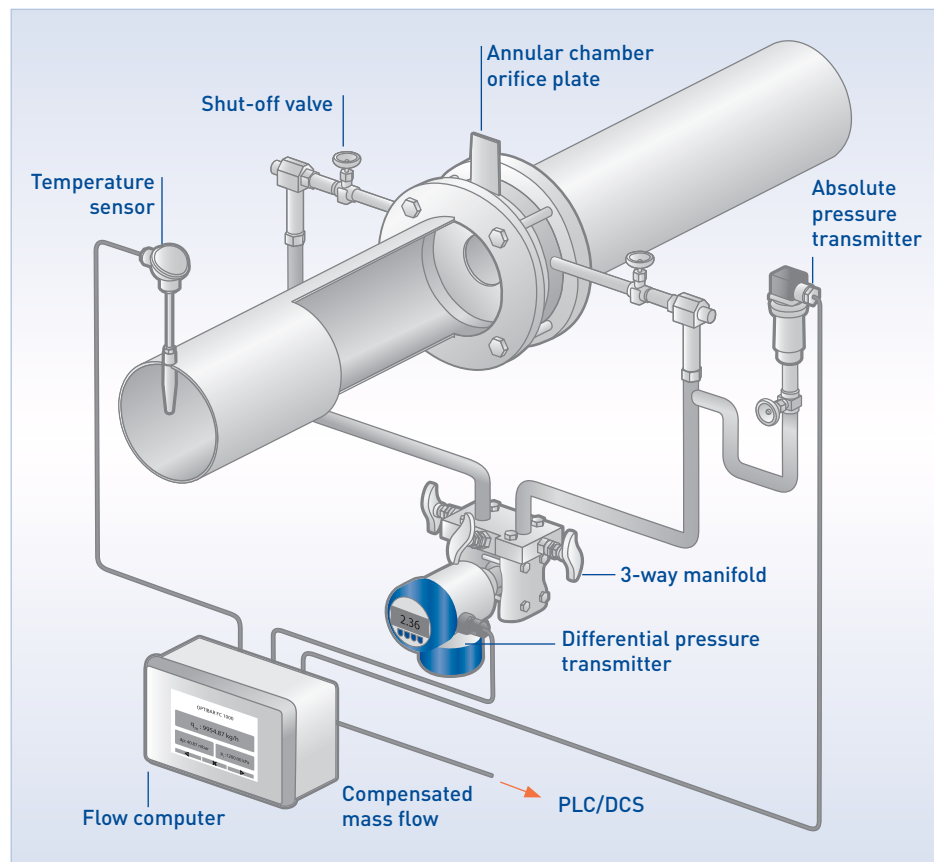

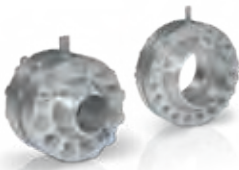

Orifice plates

	Raised face (RF) or ring type joined (RTJ) designs	With flat sealing face and corner taps	With annular chamber and corner taps	Assembly with measuring flanges acc. ASME 16.36
	OPTIBAR OP 1100/1110	OPTIBAR OP 3100/3200	OPTIBAR 4100	OPTIBAR OP 5100/5110
				
Medium	Gas, liquid and steam	Gas, liquid and steam	Gas, liquid and steam	Gas, liquid and steam
Type	Separate	Compact, separate	Separate	Separate
Sizing	EN ISO 5167: 2003; ASME MFC-3M 2007; AGA 3; ASME PTC 19.5 2004; GOST 8.586; RD 50-411-83	EN ISO 5167: 2003; ASME MFC-3M 2007; AGA 3; ASME PTC 19.5 2004; GOST 8.586; RD 50-411-83	EN ISO 5167: 2003; ASME MFC-3M 2007; AGA 3; ASME PTC 19.5 2004; GOST 8.586; RD 50-411-83	EN ISO 5167: 2003; ASME MFC-3M 2007; AGA 3; ASME PTC 19.5 2004; GOST 8.586; RD 50-411-83
Uncertainty / Accuracy	Uncertainty of C: $\pm 0.5...0.8\%$	Uncertainty of C: $\pm 0.5...0.8\%$	Uncertainty of C: $\pm 0.5...0.8\%$	Uncertainty of C: $\pm 0.5...0.8\%$
Turn down ration (calibrated)	6:1 (12:1)	6:1 (12:1)	6:1 (12:1)	6:1 (12:1)
Pressure loss	40...95%	40...95%	40...95%	40...95%
Max. pressure	300...2500#	PN10...100	PN10...100	300...2500#/600...2500#
Max. temperature	+400°C/+752°F	+400°C/+752°F	+400°C/+752°F	+400°C/+752°F
Line size	1...24"	DN50...600	DN50...600	1...24"
Material primary element	316L	1.4404	1.4404	316L
Material mounting parts	n.e / Soft Steel, 316L	P305GH, 1.4404	P305GH, 1.4404	SA105, 316L
Optional temperature probe	no	no	no	no

Differential pressure transmitter for flow applications, already with integrated absolute pressure measurement for combination with all orifice plates, averaging pitot tubes and meter runs.	
	OPTIBAR DP 7060 C
	
Accuracy (of calibrated span)	
Reference accuracy DP	$<\pm 0.065\%$ up to TD 10:1
Long-term stability	$<\pm 0.1\%$ within 5 years
Total performance	$<\pm 0.18\%$
Max. turn down	100:1
Reference accuracy pabs.	$<\pm 0.1\%$
Pressure range	
Sensor	Piezoresistive
Measurement range	10, 30, 100, 500 mbar, 3, 16 bar/0.15, 0.4, 1.4, 7.2, 43.5, 232 psi
Line pressure	40, 160, 400 bar/580, 2320, 5800 psi
Temperature range	
Process	-40...+85°C/-40...+185°F
Ambient	-40...+80°C/-40...+185°F
Configuration	
PC Tool	Free DTM, also USB interface
Software / HHT	Yes - generic and DD
Local	With optional display and adjustment module
Material	
Housing	DIN housing in 1- or 2-chamber configuration: 316L, aluminum, 316L [electro-polished], plastic (PBT)
Diaphragm material	316L, Hastelloy C276
Communication	
Output	4...20 mA, HART® 7, PA, FF
Approvals	
Ex	ATEX / IECEx Ex ia, Ex d, Ex t *
Functional Safety	SIL 2/3

*Available 2018

Averaging pitot tubes / Meter runs

	With multiple impact-sensing ports	Orifice meter run assembly with cornertaps and annular chambers	Cone meter run with single taps
	OPTIBAR PT 2000	OPTIBAR MR 4300	OPTIBAR 6300
			
Medium	Gas, liquid and steam	Gas, liquid and steam	Gas, liquid and steam
Type	Compact, separate	Compact, separate	Compact, separate
Sizing	KROHNE standard	EN ISO 5167: 2003; ASME MFC-3M 2007; AGA 3; ASME PTC 19.5 2004; GOST 8.586; RD 50-411-83	EN ISO 5167
Uncertainty / Accuracy	<±1% uncalibrated; <±0.5% calibrated	Uncertainty of C: ±0.5...0.8% calibrated: ±0.3...0.4%	Uncertainty of C: ±5% calibrated: ±0.25...0.35%
Turn down ration (calibrated)	5:1 (7:1)	6:1 (12:1)	6:1 (12:1)
Pressure loss	5...12%	40...95%	40...95%
Max. pressure	PN40	150...600#; PN10...100	300...600#
Max. temperature	+400°C/+752°F	+400°C/+752°F	+400°C/+752°F
Line size	2...800"; DN50...2000	1/2...4"; DN15...10	4...24"
Material primary element	316L	316L/1.4404	316L
Material mounting parts	A105, 316L, 16Mo3	316L/1.4404	SA105
Optional temperature probe	yes	no	no

Measuring principle: Deflector plate



DW 181
For clean liquids,
G3/4...2, 3/4...2 NPT

DW 182
For clean liquids,
DN15...65, 1/2...2 1/2"
ASME

DW 183
For clean liquids,
DN65...200, 3...8" ASME

DW 184
Insertion-type flow controller
for pipe diameter ≥ 250 mm / 10",
process connection DN150,
6" ASME

Measuring principle: Electromagnetic



DWM 1000
With binary output

DWM 2000
With 4...20 mA output

Flow controllers

Highlights DWM 1000, 2000:

- Measurement and monitoring of electrically conductive liquids, pastes and suspensions
- Sturdy construction, no moving parts, maintenance-free
- Wetted parts made of stainless steel and ceramic
- FT Tuchenhagen® connection for hygienic applications
- Optional LCD indicator e.g. for on-site calibration
- IP68 stainless steel housing for immersed applications
- Long sensor for large pipes or open channels
- For pipelines \geq DN25/1"

Electromagnetic flow controllers

The measuring principle

As early as 1832, Faraday tried to determine the speed of the current in the Thames by measuring the voltage induced in flowing water by the earth's magnetic field. Electromagnetic flow measurement is based on Faraday's Law of induction. According to this law, a specific voltage is induced in a conductor or conductive medium that moves through a magnetic field. This voltage is proportional to the speed of movement of the medium.

On electromagnetic flow controllers, the induced voltage is tapped via one reference electrode and one measuring electrode in conducting contact with the medium.

An electronic converts the signal into a proportional output signal.

Sturdy and maintenance-free: Flow switch DWM 1000 and flowmeter DWM 2000

Industries:

- Water & Wastewater
- Food & Beverage
- Chemical
- Pharmaceutical
- Process industry
- Pulp & Paper
- Metal & Mining
- Steel

KROHNE invented and founded the industrially used electromagnetic flow measuring technology more than 45 years ago. Today, we continue to impress customers with our innovations in this field.

With the DWM 1000 and DWM 2000 flow controllers, we offer two sturdy units.

Depending on the design, the flow speed is monitored (DWM 1000) or measured and output via a 4...20 mA (DWM 2000).

The only prerequisite is that the electrical conductivity of the medium be at least 20 μ S/cm. DWM 1000 and DWM 2000 flow controllers are ideal for use with largely homogenous liquids, pastes and sludges – even with solid content.

Mechanical flow controllers

The measuring principle

With the flow controllers DW 181 to 184, the liquid flows against a springmounted disc. The position of the disc changes with increasing flow. A built-in magnet transmits the position to the display and also activates the limit switch.

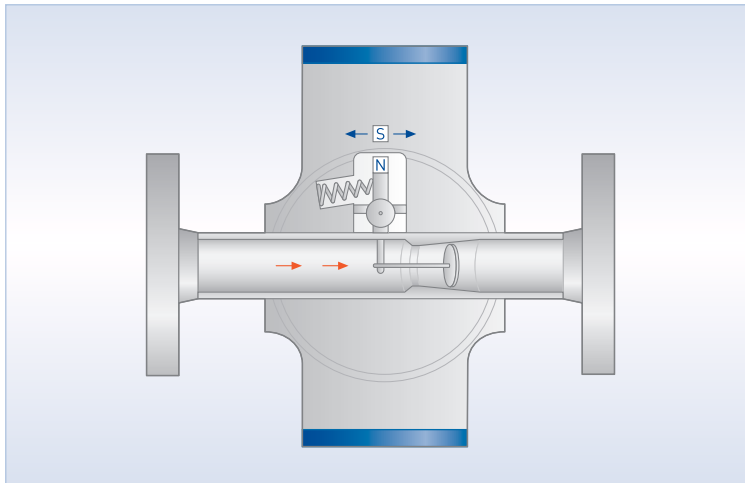

Always the right choice: Flow controllers DW 181, 182, 183, and 184

With the flow controllers DW 181, 182, 183 and 184, KROHNE offers the ideal flow control solution for virtually any process connection.

Each device is equipped with a limit switch (dry reed contact) and it is possible to install another switch at any time. For greater switching energies of up to 1200 VA, an additional amplifying relay can be installed.

Choose the display which is most adapted to your needs: DW 181, 182, 183, 184 can be ordered with two display types, G and A.

The G display enables visual monitoring of the flow via a linear 10-point scale. The switching point can be changed at any point along the way. The A display allows a more accurate reading of the flow value (e.g. in l/h or in m³/h) via a scale. With this display, the switching points can be set even when there is no flow.



Industries:

- Power Generation
- Steel
- Metal & Mining
- Petrochemical
- Oil & Gas
- Chemical
- Food & Beverage
- Water & Wastewater

Highlights DW 181 to DW 184:

- One or two dry reed limit switches
- For horizontal or vertical pipes (DW 181 to 183)
- Insertion-type for horizontal pipes $\varnothing \geq 250$ mm/10" (DW 184)
- Available with threaded, flange or mounting flange connectors
- Two different flow displays (G and A) to choose from (DW 181 to 183)
- High-temperature design up to max. +300 °C/+572 °F
- Ex-versions (Ex d, Ex i)
- Tropical version with Amphenol® sockets and a double coating of epoxy on device
- Local indication without power supply, can be used as variable area flowmeter
- Additional amplifying relay for switching energies up to 1200 VA

Flow controllers

	Mechanical flow controllers	Electromagnetic flow controllers
	DW 181 to 184	DWM 1000
		
Measuring accuracy	±15% of switching point	When $v > 1$ m/s or 3.3 ft/s: accuracy ±5% of switching point when $v < 1$ m/s or 3.3 ft/s: accuracy ±2% of switching point, ±3 cm/s/±1.2 in/s
Repeatability	±3% of switching point	±1% of switching point
Limit switches	1 or 2 binary outputs; 1 or 2 relay outputs	1 binary output
Output	-	-
Communication	-	-
Power supply	Switching voltage AC: 24, 48, 110, 240 VAC; switching voltage DC: 24, 48, 110 VDC	48...240 VAC; 48 VDC; relay voltage: 48, 110, 240 VAC; 48 VDC
Protection category	Polycarbonate housing: IP65 (non-Ex and Ex i), aluminum housing: IP65 (non-Ex and Ex d), HT version (alu terminal box): IP20, 66	Aluminum housing: IP65, stainless steel housing: IP68
Nominal size		
Pipe diameter	≥DN15/1/2"	≥DN25/1"
Connection	3/4...2" NPT; G3/4...2 DN15...200/1/2...8"	Std fitting G1A; screw-on welding socket (Ø39 mm/Ø1.25") Optional long sensor 1 1/2" NPT; G1 1/2 screw-on welding socket (Ø60 mm; Ø2.4"); spool piece (option) DN25...50/1...2", DN32/1 1/4" on request; Optional FT Tuchenhausen VARIVENT® connection for hygienic applications
Pressure ratings		
Max. operating pressure	100 barg/1450.4 psig, higher on request	25 barg/362.6 psig
Process conditions		
Medium	Homogeneous, clean liquids	Conductive liquids, pastes, slurries ≥20 µS/cm
Viscosity standard	≤30 mPas; 0.02 lb/fts	-
Viscosity special version	≤250 mPas; 0.16 lb/fts	-
Measuring range	0.2...4 m/s/0.66...13.1 ft/s	0.1...9.9 m/s/0.3...32.5 ft/s
Temperature ranges		
Process	-40...+150°C/-40...+302°F -25...+300°C/-13...+572°F (high temperature)	-25...+150°C/-13...+302°F -25...+60°C/-13...+140°F (IP68)
Ambient	-40...+80°C/-40...+176°F -25...+60°C/-13...+140°F (high temperature)	-25...+60°C/-13...+140°F
Materials		
Measuring tube	Bronze, stainless steel	Stainless steel, zirconium
Measuring system	Stainless steel	Electrode: platinum
Approvals		
Ex	ATEX	-
Miscellaneous	EAC	EAC

Electromagnetic flow controllers	
DWM 2000	
	
Measuring accuracy	When $v > 1$ m/s or 3.3 ft/s: accuracy $\pm 5\%$ of measured value ($\pm 2\%$ if calibrated onsite) when $v < 1$ m/s or 3.3 ft/s: accuracy $\pm 2\%$ of measured value, ± 3 cm/s/ ± 1.2 in/s
Repeatability	$\pm 1.5\%$ of measured value
Limit switches	-
Output	4...20 mA, 3-wire
Communication	RS232
Power supply	12, 24 VDC, 50 mA
Protection category	Aluminum housing: IP65, stainless steel housing: IP68, aluminum housing with display: IP55
Nominal size	
Pipe diameter	\geq DN25; 1"
Connection	Std fitting G1A, screw-on welding socket ($\varnothing 39$ mm/ $\varnothing 1.25$ "") Optional long sensor 1 1/2" NPT; G1 1/2, screw-on welding socket ($\varnothing 60$ mm/ $\varnothing 2.4$ "") spool piece (option) DN25...50/1...2", DN32/1 1/4" on request Optional FT Tuchenhausen VARIVENT® connection for hygienic applications
Pressure ratings	
Max. operating pressure	25 barg/362.6 psig
Process conditions	
Medium	Conductive liquids, pastes, slurries ≥ 20 μ S/cm
Viscosity standard	-
Viscosity special version	-
Measuring range	1...8 m/s/3.3...26.3 ft/s
Temperature ranges	
Process	-25...+150°C/-13...+302°F -25...+60°C/-13...+140°F (IP68)
Ambient	-25...+60°C/-13...+140°F
Materials	
Measuring tube	Stainless steel, zirconium
Measuring system	Electrode: platinum
Approvals	
Ex	-
Miscellaneous	EAC

Communication technology

Drivers · Protocols · Configuration · Diagnostics



Open for the future

KROHNE is committed to making communication convenient. Which is why our field devices communicate reliably with controllers, control systems and PCs, and can also be used for a variety of control and regulating tasks.

Protocols and interfaces

We support proven and established protocols as well as new ones for certain industries, e.g. EtherNet/IP™ for the food and beverage industries, or PROFINET® for the water and wastewater sector.

Device integration

KROHNE meets all of the prerequisites for integration into modern plant asset management systems, based on integration technologies such as DD/EDD and FDT/DTM.

We are a longstanding member of PACTware™ and the FDT Group®. Since 2003, we provide DTMs and EDDs for our field devices with HART®, PROFIBUS® or FOUNDATION™ fieldbus interfaces.



Configuration and diagnostics via DTMs



Easy navigation, device status available anytime



Simple parameterisation supported by graphic elements

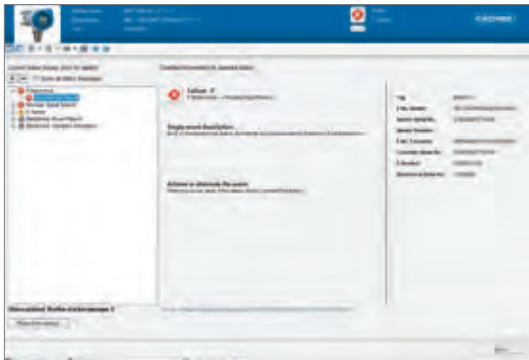

Detailed diagnostics overview with recommendations to resolve actual events

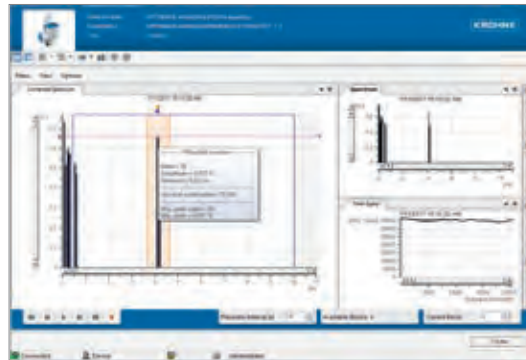

Advanced monitoring functions with optional recording of events

Fast and convenient access to process and device data from any level

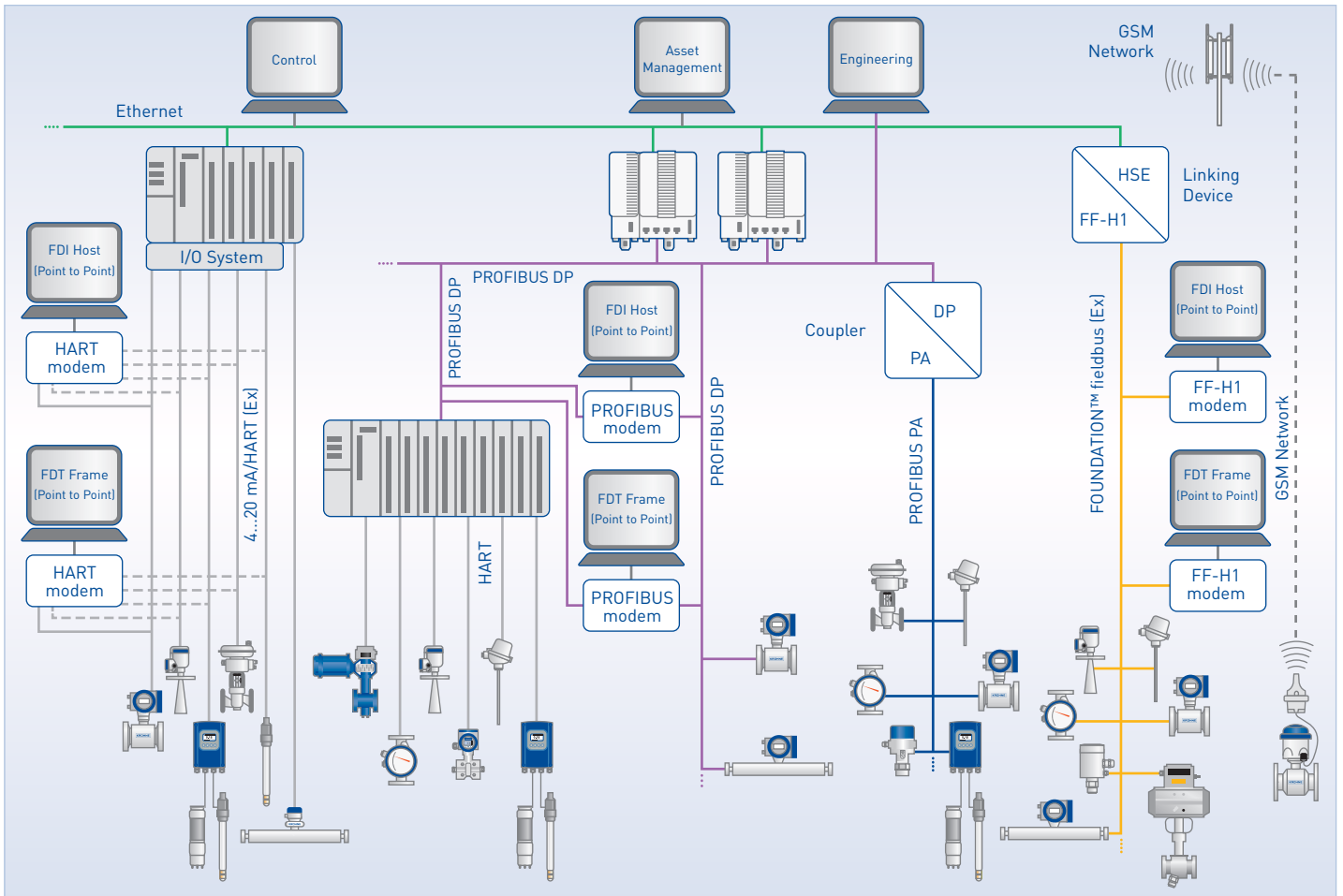

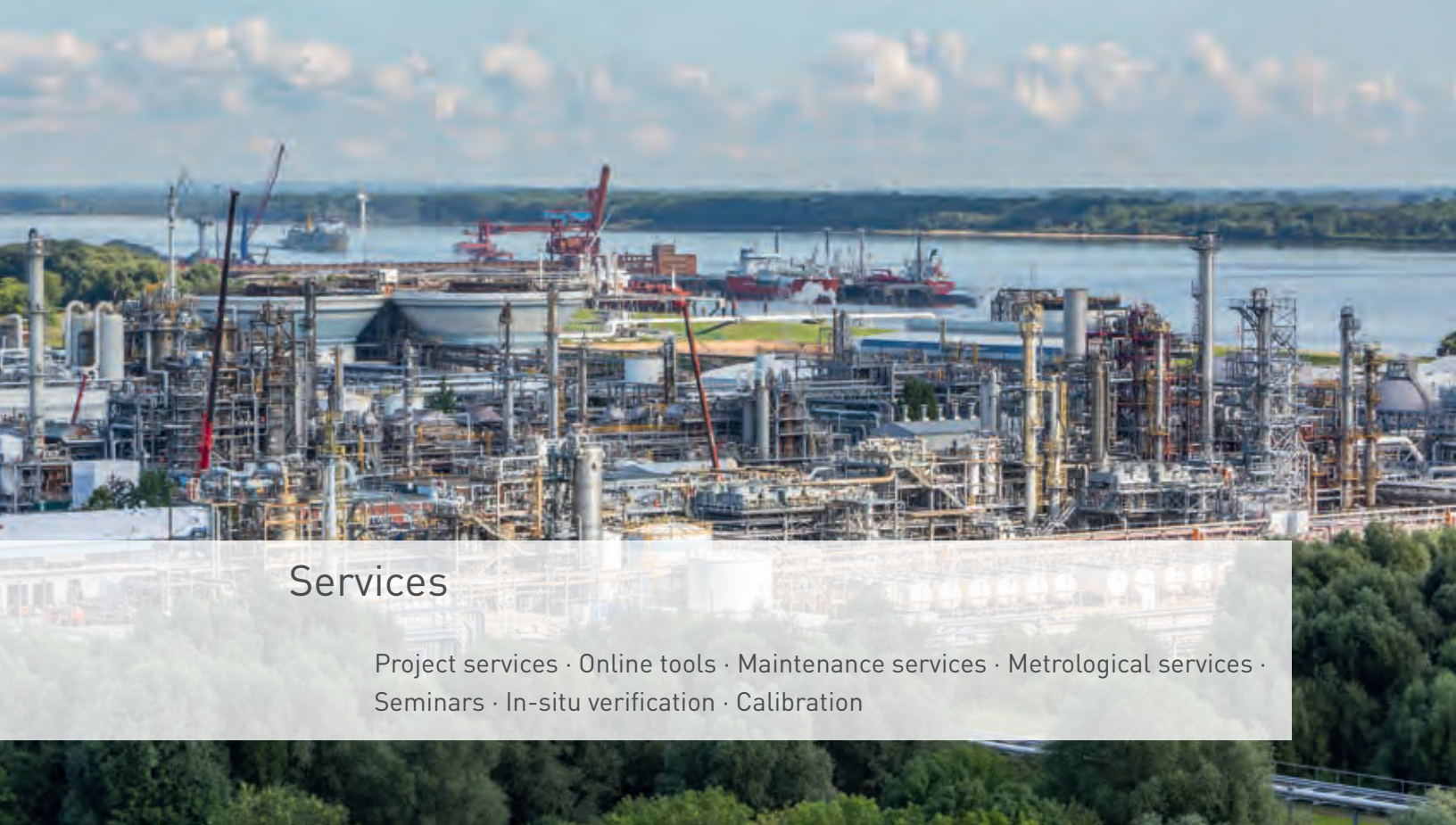

Services

Project services · Online tools · Maintenance services · Metrological services · Seminars · In-situ verification · Calibration

Beyond the highest requirements

From engineering and planning to commissioning, training and documentation: our services cover all project stages, and can be offered for all enterprise sizes:

- Complete project management for instrumentation projects
- Engineering
- Commissioning
- On-site start-up
- Product training (on-site)
- Calibration, (in-situ) verification and documentation
- Maintenance services
- Seminars and trainings on various topics

Please see right page for more details on selected services.



Commissioning of flowmeters

Online tools:



PiCK

Enter the serial number and get device specific documents, e.g. manuals, handbooks, calibration certificates, etc.:
pick.krohnegroup.com

Configure It

Configure It

Configure flow and level devices and get free 2D/3D CAD data:
www.krohne-direct.com

Maintenance services

Choose from maintenance and service contracts tailored to suit all business sizes and needs:

- Spare parts and consumables
- Field service and on-site repair
- Returns
- Workshop repair
- Helpdesk

Metrological accreditation of custody transfer applications

We offer special services for metrological accreditation of measuring and loading systems for liquids and gases, according to local fiscal regulations:

- Project management from planning to commissioning, training and documentation
- For mobile and stationary measuring systems

Seminars: KROHNE Academy & KROHNE Academy online

KROHNE Academy is a series of seminars in collaboration with leading automation companies. Taking place in various countries, it addresses key operating issues, from plant safety to ways of increasing efficiency and controlling costs, and shows possible solutions. Should your interest be more towards working “hands-on” with our devices, then our service academy is what you are looking for. Learn more about KROHNE Academy at www.krohne.com

KROHNE Academy online is an online eLearning platform, focusing on industrial process instrumentation. It comprises electronic learning content with full audio, explaining measuring technology without relation to specific manufacturers. Register now for free and start your training at academy-online.krohne.com



Large team of field service engineers and technicians



MID MI-005 tanker filling system for liquefied gas



Functional safety seminar at KROHNE headquarters, Duisburg, Germany

In-situ verification

OPTICHECK is the essential tool to assure that your process measuring devices are performing according to specification. When connected to an installed meter (in-situ), it gathers data to ensure that the meter is performing within 1% of the factory calibration.

- Printed individual verification certificate
- Preventive maintenance and service features
- Storage of verification data
- Download factory calibration settings from KROHNE manufacturing database



Calibration from KROHNE: Certainty you can count on

Calibration of high pressure/high flow gas and liquid meters

For oil&gas flow metering systems, our partner EuroLoop in Rotterdam, The Netherlands, offers testing and calibration according to European MID, EN or IEC standards or OIML recommendations.

With their large closed loop facilities, single meters or complete skids can be calibrated with:

- Natural gas: 20...30,000 m³/h for sizes 6...36" up to ANSI 900 with best overall uncertainty (CMC) of 0.17%
- Liquid hydrocarbons: sizes 4...30" up to 5,000 m³/h, large range of Reynolds numbers, viscosities 1...400 mm²/s (cSt), with best overall uncertainties 0.02% for volume and 0.04% for mass

The world's most precise volumetric calibration rig for flowmeters up to DN3000/120"

Calibration is one of KROHNE's core areas of expertise. If you buy a KROHNE product, you will get a measuring device that performs most accurate with low uncertainty under real process conditions.

To achieve this, we operate more than 140 calibration facilities for volume flow, mass flow, level, temperature, density and pressure to (wet-)calibrate any device we manufacture. For example, every flowmeter is wet-calibrated using water or air as standard before leaving our facilities.

We can also provide customer specific calibration such as:

- Carry out multipoint calibrations
- Vary different parameters such as temperatures, viscosities, pressures etc.
- Use the actual medium or similar
- Build or emulate customer-specific flow geometries
- Use piping provided by the customer

For calibration we only use direct comparison of measurands (e.g. we calibrate our Coriolis mass flowmeters with a gravimetric weighing system). Our calibration rigs are the most accurate used in measuring device production worldwide: the accuracy of the reference is usually 5 to 10 times better than that of the meter under test.

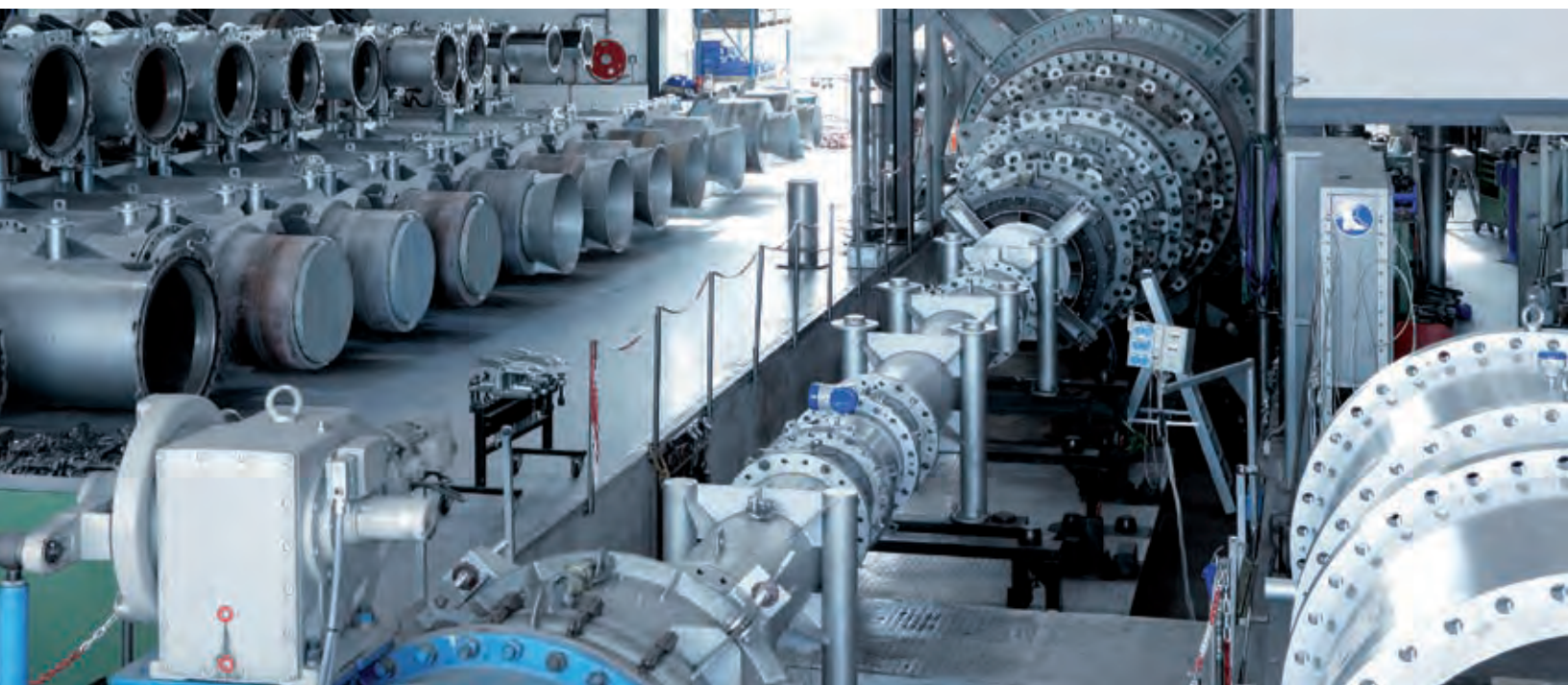



Stretch for calibration of FMCW level transmitters

Volumetric piston prover

This goes for small as well as for very large sizes: KROHNE operates the world's most precise volumetric calibration rig for flowmeters up to DN3000/120" with a certified accuracy of 0.013 %. The reference vessel is a 44 m/144 ft high tank containing almost 0.5 million litres/132,000 gal (US) of water which allows for a maximum flow rate of 30,000 m³/h/7,925,000 gal (US)/h.

Certified technology for fiscal & custody transfer applications

Our meters can be calibrated and certified according to various standards such as OIML, API, Measuring Instruments Directive (MI-001, 002, 004, 005), GOST, etc. The standards we use for calibration are ISO/IEC 17025 accredited and traceable to international or national standards. Regular inspections by national metrology institutes, round robin tests and alignments with national and international metrological standards according to ISO 9000 and EN 45000 guarantee the quality and comparability of our calibration rigs. Staff performing the calibrations are trained and given regular re-trainings to ensure quality and continuity.



KROHNE – Products, Solutions and Services

- Complete product portfolio: flow, level, temperature, pressure, process analytics
- Application-specific system solutions for various industries
- Services for instrumentation projects

Contact

KROHNE North America
KROHNE, Inc.
55 Cherry Hill
Beverly, MA 01915
USA
Tel.: 800-FLOWING (356-9464)
Tel.: 978-535-6060 in MA
Fax: 978-535-1720
info@krohne.com

Global companies and representatives
The current list of all KROHNE contacts
and addresses can be found at:
www.krohne.com

