

EP series



Operating instructions Planetary gear reducers and gearmotors



Index

1	General and safety informations	5
	1.1 Recycling	5
	1.2 Safety	5
2	Use conditions and limits	6
3	Supply status	7
	3.1 Name plate	7
	3.2 Lubricant	8
	3.3 Painting	8
	3.4 Protections and packing	8
4	Lifting, handling and storage	9
	4.1 Receipt	9
	4.2 Lifting and handling	9
	4.3 Storage	10
5	Installation	11
	5.1 General	11
	5.2 Screws and tightening torques	12
	5.3 Flange mounting	14
	5.4 Gear reducer mounting with slewing outputs	15
	5.5 Foot mounting	15
	5.6 Shaft mounting arrangements	16
	5.7 Torque arm	16
	5.8 Shaft end mounting	20
	5.9 Hollow shaft mounting with shrink disc	20
	5.10 Accessories mounting	23
6	Universal flange adapter	28

7	Motor mounting or replacement	29
	7.1 Electric motors	29
	7.2 Hydraulic motors	30
8	Lubrication	31
9	Commissioning	33
10	Cooling unit systems	35
11	Backstop device	39
12	Maintenance	39
13	Mounting positions, oil quantities and tanks	41
14	Plug positions and types	52
15	Troubles: causes and corrective actions	56
16	PB series - Parking brakes	57

	Commissioning	63
	Maintenance	63
	Oil change	64
	Seal change	64
	Troubles: causes and corrective actions	64

This document provide information about handling, installation and maintenance of the planetary gear reducers. All the people who work with the products presented in this operating instructions must carefully read and apply them rigorously. The products correspond to the technical level reached at the moment the document is printed. Rossi S.p.A. reserves the right to introduce, without notice, the necessary changes to improve efficiency and safety of its products.

1.1 Recycling



Keeping in mind the instructions in force:

- the elements of casing, gear pairs, shafts and bearings of gear reducer must be transformed into steel scraps. The elements in cast iron will be subjected to the same treatment if there is no particular instructions;
- exhausted oils must be recycled and treated in accordance with environmental legislation.

1.2 Safety

The paragraphs marked with symbols shown below contain dispositions to be strictly respected in order to assure personal safety and to avoid any heavy damages to the machine or to the system.



- Live
- At temperature higher than 50 °C
- Rotating during operations
- attention



- Don't use to lift



- Lifting point

IMPORTANT: the components supplied by Rossi must be incorporated into machinery and **should not be commissioned before the machinery in which the components have been incorporated conforms to:**

- **Machinery directive 2006/42/CE and subsequent updatings;**
- **"Electromagnetic compatibility (EMC)" directive 2004/108/EC and subsequent updatings.**



ATTENTION!

Components in non-standard design or with special executions or with constructive variations may differ in the details from the ones described here following and may require additional information.



ATTENTION!

For the installation, use and maintenance of the electric motor (standard, brake or non-standard motor) or of the possible motor-variator and/or the electric supply device (frequency converter, soft-start, etc.) and accessories, if any (flow indicators, independent cooling unit, thermostat, ect) consult the attached specific documentation. If necessary, require it.



ATTENTION!

For any clarification and/or additional information consult Rossi S.p.A. and specify all name plate data.

Gear reducers and gearmotors of presented in this operating instruction are normally suitable for installations in industrial areas: **additional protection measures**, if necessary for different employs, must be adopted and assured by the person responsible for the installation.

An incorrect installation, an improper use, the removing or disconnection of protection devices, the lack of inspections and maintenance, improper connections may cause severe personal injury or property damage.

Therefore, the products must be moved, installed, commissioned, handled, controlled, serviced and re-paired **exclusively by responsible qualified personnel.**

Qualified personnel must be specially trained and have the experience necessary to recognize risks associated with these products and to avoid possible hazards.

It is recommended to pay attention to all existing safety laws and standards concerning correct installation.

Whenever personal injury or property damage may occur, due to falling or projecting parts of gear reducer or of its parts, foresee adequate supplementary protection devices against:

- release or breakage of fastening screws;
- rotation or unthreading of the gear reducer from shaft end of driven machine following to accidental breakage of the reaction arrangement;
- accidental breakage of the shaft end of driven machine.

When operating on gear reducer or on components connected to it, the machine must be at rest: disconnect motor (including auxiliary equipments) from power supply, gear reducer from load, be sure that safety systems are on against any accidental starting and, if necessary, pre-arrange mechanical locking devices (to be removed before commissioning).



ATTENTION!

During the operation the gear reducers may have hot surfaces.



ATTENTION!

During the operations take protection due to possible warm oil contact.

If deviations from normal operation occur (temperature increase, unusual noise, etc) immediately switch off the machine.

Use conditions and limits

Gear reducers are suitable to operate at ambient temperature $0\text{ °C} \div +40\text{ °C}$ (with peaks $-20\text{ °C} \div +50\text{ °C}$), with standard seal rings and components.

The operation outside this range, with a minimum of -40 °C and a maximum of $+60\text{ °C}$, must be evaluated in relation to the specific operating conditions, duty cycle, type of lubricant, type of seals and cooling/heating system (where possible); please contact Rossi S.p.A.

Allowed operational and storage ambient temperature in relation to lubricant type ¹⁾

		Synthetic Lubricant	Mineral Lubricant
Ambient Temperature T_{amb}	Running conditions		
	Minimum ambient temperature	-20 °C	-10 °C
	Maximum ambient temperature	+50 °C	+40 °C
	Minimum ambient temperature for ATEX design	-20 °C	-10 °C
	Maximum ambient temperature for ATEX design	+40 °C	+40 °C
	Storage condition		
Minimum ambient temperature of storage condition	-10 °C	-10 °C	
Maximum environment temperature of storage condition	+50 °C	+50 °C	
Oil Temperature T_{oil}	Minimum oil temperature for partial load starting condition ²⁾	-20 °C	-10 °C
	Minimum oil temperature for full load starting condition	-10 °C	-5 °C
	Maximum nominal stabilized oil temperature allowed in continuous running condition (S1)	+95 °C	+95 °C ³⁾
	Maximum peak and occasional oil temperature allowed with intermittent duty only	+110 °C	+110 °C

1) For selection of lubricant and optimal viscosity according to temperature T_{amb} and in case of independent lubrication unit, refer to chapter 8.8 (Lubrication).

For starts and services with $T_{oil} < 0\text{ °C}$, consider higher absorption on the electric motor according to the type of lubricant.

2) If full load service is required, provide gradual starting and stopping ramps, avoiding overloads and shocks.

3) For temperature value of $T_{oil} > 75\text{ °C}$ and $< 95\text{ °C}$ it is recommended to use oils with at least viscosity grade 30 cSt at 95 °C.

Name plate

Name plate

Every gear reducer is provided with a name plate in anodized aluminium containing main information necessary for a correct identification of the product; the name plate must not be removed and must be kept integral and readable. All name plate data must be specified on eventual spare part orders.

Assembled by Rossi Italy

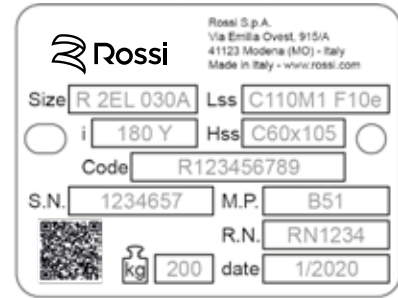
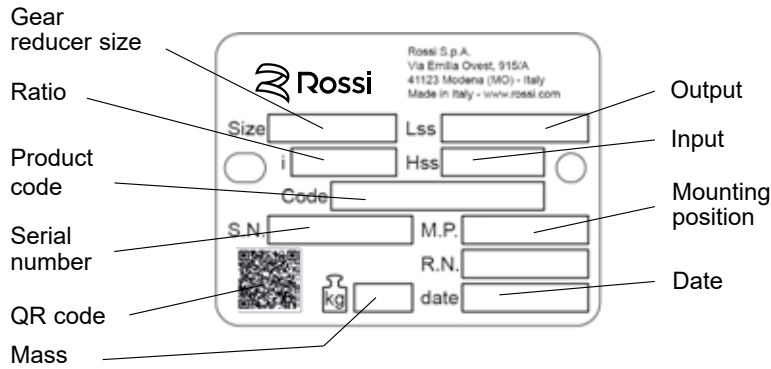

Assembled by subsidiaries

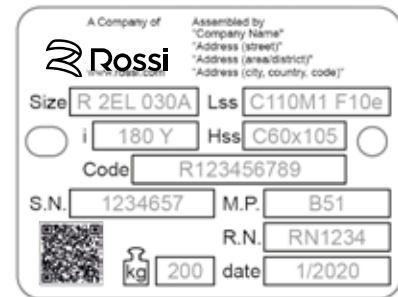
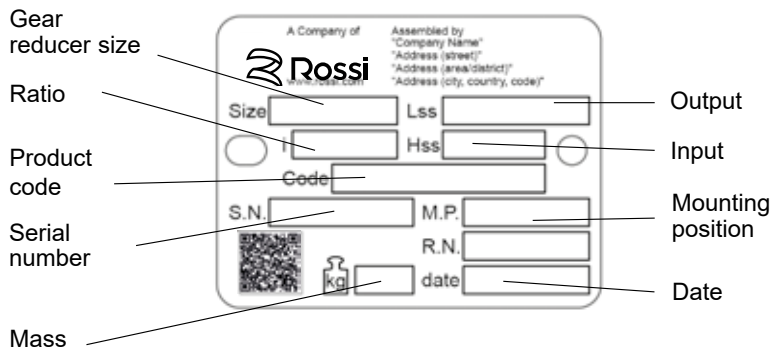

3.2

Lubricant

If not differently stated, gear reducers until size O21A are supplied filled for the specific mounting position involved with synthetic PAO oil as indicated in an additional label.

3.3

Painting

Standard painting

Internal painting	External painting		Notes
	Final color Blue RAL 5010	Features	
Single-compound ester epoxy or phenolic resin basis primer (prepainted)	Single-compound ester epoxy or phenolic resin basis primer (prepainted) + Water-soluble polyurethane dual-compound enamel	Resistant to atmospheric and aggressive agents (atmospheric corrosivity category c3 according to ISO 12944-2). Suitable for further coats of dual-compound paints only ¹⁾	The internal painting does not resist polyglycol synthetic oils (polyalphaolefines synthetic oils are suitable). Remove by a scraper or solvent the possible paint of gear reducer coupling surfaces

1) Before adding further coats of paint, properly protect the seal rings and carefully degrease and sand the gear reducer surfaces (instead of sanding it is possible to apply a water-based primer coat).

3.4

Protections and packing

Overhanging free shaft ends and hollow shafts are treated with protective anti-rust long life oil.

All internal parts are protected with protective anti-rust oil. Unless otherwise agreed in the order, products are adequately packed: on pallet, protected with a polyethylene film, wound with adhesive tape and strap (bigger sizes); in carton pallet, wound with adhesive tape and strap (smaller sizes); in carton boxes wound with tape (for small dimensions and quantities).

If necessary, gear reducers are conveniently separated by means of anti-shock foam cells or of filling cardboard.

Generally the packing is suitable for the normal road/rail transport. For sea transport it is necessary to foresee a special packing, when ordering.

Before handling or transporting the gear reducers, be sure that the packing is in good conditions and suitable for the transport. Do not stock packed products on top of each other.

At receipt verify that the unit corresponds to the one ordered and has not been damaged during the transport, in case of damages, report them immediately to the courier.

Avoid commissioning gear reducers, that are even slightly damaged. Report any non-compliance to Rossi S.p.A..

Lifting and handling

First make sure that the lifting equipment (e.g. crane, hook, eye bolt, straps etc.) is suitable for the weight and size of the gear reducer (the weight of the product are given in the name plate). When lifting, use only the attachment point marked in the following figures.

Pay attention to avoid lifting (max 15° during handling) and, if necessary, use additional straps only to balance the load.

Do not use front threads at the input shaft ends to lift the gear reducers.



Warning!

- Suspended load can fall
- Do not stand under the load
- Improper transport may result in damage to the gear reducer

Lifting and handling

Sizes 001A ... 021A details

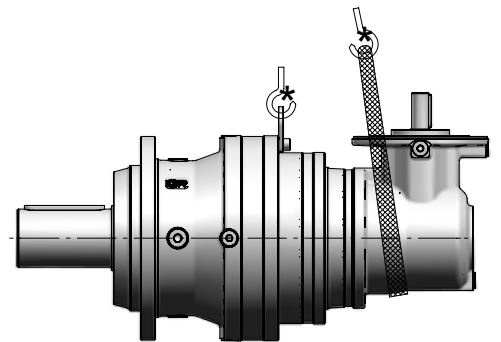
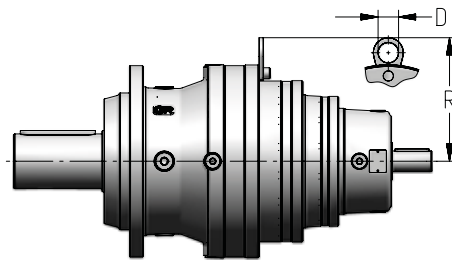

Sizes	D ∅	R
001A, 002A	–	–
003A ... 006A	25	151
009A ... 015A	30	181
018A, 021A	35	213

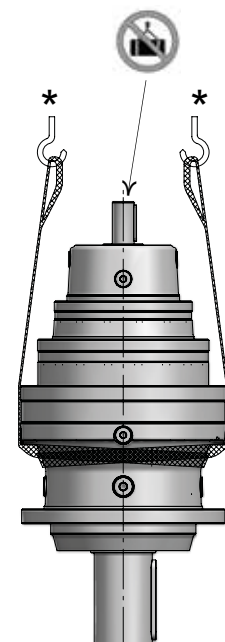
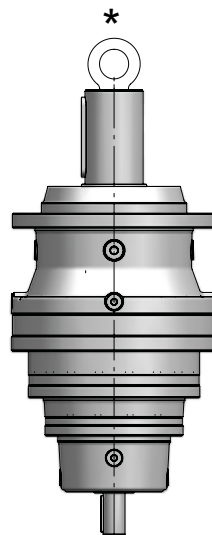

* Not included

Lifting and handling

Sizes 022A ... 710A details

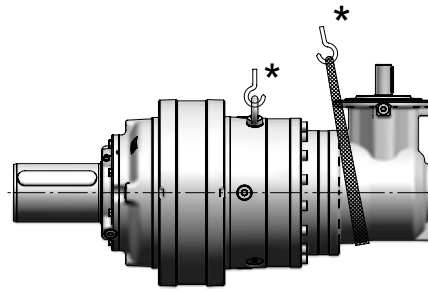
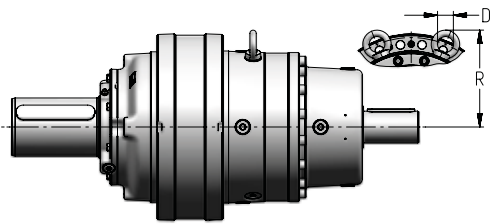

Size	D ∅	R		S	
		1EL ... 4EL 3EB, 4EB	2EB	1EL ... 4EL 3EB, 4EB	2EB
022A	25	180	181	221	222
030A	30	184	204	197	231
031A	30	193	228	207	259
042A	30	193	209	207	259
043A	30	193	110	207	270
060A	30	170	243	229	277
061A	30	170	–	229	–
085A	30	187	284	252	312
125A	30	225	312	280	343
180A	35	230	–	312	–
250A	40	257	–	348	–
355A	50	299	–	404	–
500A	50	324	–	439	–
710A	60	362	–	489	–

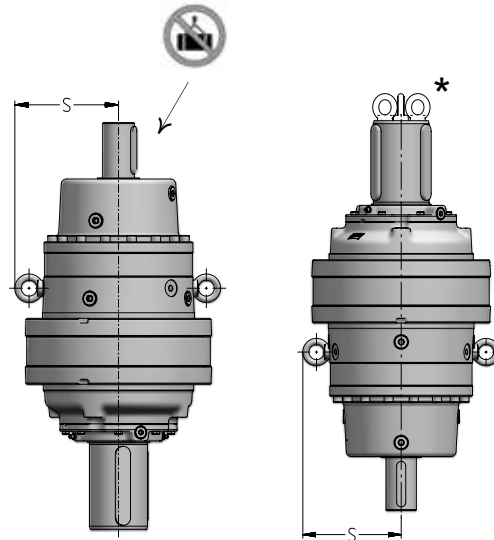

* Not included



✓ Lifting and handling **correct**

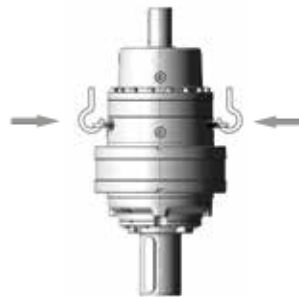

⊗ Lifting and handling **incorrect**

4.3

Storage

Environment should be sufficiently clean, dry and free from excessive vibrations ($v_{eff} \leq 0,2$ mm/s) to avoid damage to bearings (excessive vibration should also be guarded during transit, even if within wider range) and ambient storage temperature should be $0 \div +40$ °C: peaks of 10 °C above and below are acceptable (see also operation condition chapter 8.2).

The gear reducer filled with oil must be positioned according to the mounting position mentioned on the name plate.

Every six months rotate the shafts (some revolutions are sufficient) to prevent damage to bearings and seal rings.

In normal environments and provided there has been adequate protection during transport, the product is provided for a storage period of up to 1 year.

For a 2 year storage period in normal environment it is necessary to pay attention also to the following instructions:

- generously grease the sealing, the shafts and the unpainted machined surfaces, if any, and periodically control conservation state of the protective anti rust oil
- completely fill the gear reducers with lubrication oil

For storages longer than 2 years or in aggressive environment or outdoors, consult Rossi S.p.A..

Before the installation, verify that:

- there are no damages on shafts and on mating surfaces
- design is suitable to the environment (temperature, atmosphere, etc.). In case of installation in environment with the risk of explosion occur to require during the order the execution ATEX II 2GD e 3GD
- be sure that the structure on which gear reducer is fitted is plane, levelled and strong enough in order to assure fitting stability and vibration absence (vibration speed $v_{\text{eff}} \leq 3,5$ mm/s for $P_N < 15$ kW and $v_{\text{eff}} \leq 4,5$ mm/s for $P_N > 15$ kW are acceptable), keeping in mind all transmitted forces due to the masses, to the torque, to the radial and axial loads
- the actual mounting position corresponds to the name plate data
- where backstop device is provided, verify the correct direction according to application requirements
- carefully align the gear reducer with the motor and the driven machine (with the aid of shims if need be), interposing flexible couplings whenever possible
- mount the gear reducer so as to allow a free passage of air for cooling both gear reducer and motor (especially at their fan side, accessory fan cooling if provided)
- avoid any obstruction to the air flow; heat sources near the gear reducer that might affect the temperature of cooling air and of gear reducer (for radiation); insufficient air recycle and applications hindering the steady dissipation of heat
- verify that the gear reducer housing is dust-free in order to achieve an efficient heat dissipation
- gear reducers and gearmotors should be protected, whenever possible and by appropriate means, from solar radiation and extremis of weather; weather protection **becomes essential** when high or low speed shafts are vertically disposed or when the motor is installed vertical with fan upward
- mating surfaces (of gear reducer and machine) must be clean and sufficiently rough to provide a good friction coefficient (indicatively $Ra\ 1,6 \div 3,2\ \mu\text{m}$). Remove by a scraper or solvent the eventual paint of gear reducer on coupling surfaces and, especially in presence of external radial loads or torque required $M_2 \geq 0,7 \times M_{N2}$, apply **locking adhesives**
- when external loads are present use pins or locking blocks, if necessary

Before wiring-up the gearmotor make sure that motor voltage corresponds to input voltage. If direction of rotation is not as desired, invert two phases at the terminals.

Y- Δ starting should be adopted for no-load starting (or with a very small load) and for smooth starts, low starting current and limited stresses, if requested.

If overloads are imposed for long periods or if shocks or danger of jamming are envisaged, then motor-protection, electronic torque limiters, fluid couplings, safety couplings, control units or other similar devices should be fitted.

Protection of the motor with a thermal cut-out is recommended. Where duty cycles involve a high number of on-load starts, it is necessary to utilise **thermal probes** for motor protection (fitted on the wiring); magnetothermic breaker is unsuitable since its threshold must be set higher than the motor nominal current of rating.

Connect thermal probes, if any, to auxiliary safety circuits.

Use varistors and/or RC filters to limit voltage peaks due to contactors.

- For accessories not supplied by Rossi pay attention to their correct dimensioning; if necessary consult us.



Warning!

Bearings life, safe shaft and coupling running depend on precise alignment of the shafts.

In presence of backstop device it is not recommended to temporarily dismount the motor from the reducer to avoid damaging the device.

Carefully align the gear reducer with the motor and the driven machine (with the aid of shims if need be), interposing flexible couplings whenever possible.

Whenever a leakage of lubricant could cause heavy damages, increase the frequency of inspections and/or envisage appropriate control devices (e.g.: remote oil level gauge, lubricant for food industry, etc.).

In polluting environment, take suitable precautions against lubricant contamination through seal rings or other.

For brake or special motors, consult us for specific information.

5.2

Screws and tightening torques

According to the design and size stated on nameplate, use screws and tightening torques as shown in the following tables; at least class 10.9 is necessary but in case of heavy stresses, alternate loads and shocks use class 12.9. Screws of class 12.9 must be equipped (where indicated, e.g.:  see following table) with ISO 7089 washers (300 HV min.).

Be careful to the tightening of the 12.9 screws. Over tightening can damage them.

The suggested tightening torque value are valid for an estimated friction coefficient of $\mu = 0,14$ typical for lightly oiled steel bolts, black annealed or phosphatised and dry, cut mating threads in steel or cast iron.

Do not use lubricants altering the friction coefficient for they may overload the screw connection.

Always use dynamometric wrench or similar and verify the tightening torque after the first hours of running.

Sizes 001A ... 021A

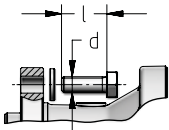
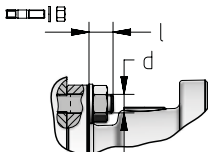
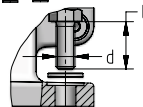
Size	Design (es. C038M1 F10a)														
	C... F... S... F... H... A... M... A...				K... F... Z... F...				K... F... Z... F...				C... P... S... P...		
															
	n°	d Ø	min	max	n°	d Ø	min	max	n°	d Ø	min	max	n°	d Ø	l min
001A, 002A	8	M10	30	40	-	-	-	-	8	M10	10	13	4	M14	40
003A	10	M12	35	35	10	M12	35	35	-	-	-	-	4	M16	45
004A, 006A	10	M12	40	50	10	M12	35	35	-	-	-	-	4	M16	45
009A, 012A	12	M14	45	55	12	M14	45	50	-	-	-	-	4	M20	55
015A	16	M14	45	55	16	M14	45	50	-	-	-	-	4	M20	55
018A, 021A	12	M16	55	75	12	M16	50	50	-	-	-	-	4	M22	60

Sizes 030A ... 710A

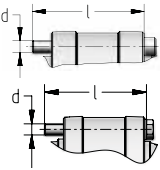
Size	Design (e.g. C100M1 F10e)		
	C... F... S... F... H... A... Z... F...	d Ø	l min
			
	n°	d Ø	l min
030A	24	M16	150
042A	28	M16	160
060A	24	M20	180
085A	28	M20	200
125A	28	M24	230
180A	32	M24	250
250A	28	M30	290
355A	32	M30	320
500A	28	M36	350
710A	32	M36	390

Sizes 030A ... 710A

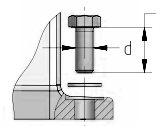

Size	Accessories ,FB		
	n°	d Ø	l min
			
	n°	d Ø	l min
030A	4	M24	65
042A	4	M27	70
060A	4	M30	85
085A	4	M33	90
125A	4	M36	110
180A	4	M39	120
250A	4	M42	130
355A	4	M45	140
500A	4	M52	160
710A	4	M56	180

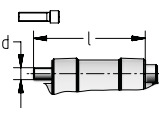
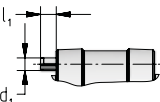
Sizes 022A, 031A, 043A, 061A

Size	Design (e.g. C100M1 F10z)					
	C... F... S... F...			C... F... S... F...		
						
	n°	d Ø	l min	n°	d ₁ Ø	l ₁ min
022A	12	M16	140	3	12	20
031A	15	M16	160	3	16	20
043A	24	M16	170	-	-	-
061A	30	M16	190	-	-	-

Where present, stop pins must be used!

Tightening torque [N m]

R					S				H			
												
size	output design	n	d	l min	output design	n	d	l min	output design	n	d	l min
007	R30b	12	M12	50	S30b	16	M10	100	H30b	10	M16	60
015	R30c	10	M16	60	S30c	16	M12	130	H30c	12	M16	55
021	R30d	24	M16	65	S30d	16	M14	140	H30d	12	M20	70
030	R30e	24	M16	65	S30e	24	M16	160	H30e	24	M20	80
042	R30f	24	M20	70	S30f	28	M16	180	H30f	24	M20	70
060	R30g	24	M20	80	S30g	24	M20	220	H30g	24	M20	80
085	R30h	24	M20	80	S30h	28	M20	240	H30h	24	M30	110
125	R30i	24	M24	90	S30i	28	M24	240	H30i	28	M24	90
180	R30j	28	M24	90	S30j	32	M24	260	H30j	32	M24	90
250	R30k	28	M30	110	S30k	28	M30	300	H30k	28	M30	110

Sizes 001A ... 021A

Size	Design (e.g. M... A...) Accessories (e.g. .WF...)		
	n°	d	l min
001A ... 002A	12	M10	30
003A ... 006A	12	M12*	40
009A ... 015A	12	M18	50
018A ... 021A	12	M20	60

*) Class 12.9.

Sizes 030A ... 710A

Size	Accessories (e.g. WF... ,WT...)		
	n°	d	l min
030A	12	M24	70
042A	16	M24	70
060A	12	M30	90
085A	16	M30	90
125A	18	M30	100
180A	28	M30	100
250A	36	M30	110
355A	44	M30	110
500A	44	M33	130
710A	48	M36	140

Tightening torque [N m]



Ø	Class		
	8.8 $M_2 < 70\% M_{n2}$	10.9	12.9 Washer must be always used (300 HV min.)
M10	50	70	85
M12	85	120	145
M14	135	190	230
M16	210	300	355
M20	400	560	675
M22	530	770	895
M24	690	1000	1165
M27	1010	1400	1705
M30	1380	1950	2330
M33	2000	2800	3375
M36	2500	3550	4220
M39	2950	4200	4980
M42	4100	5800	6920
M45	5000	7100	8440
M52	7600	10700	12800
M56	9800	13800	16540

5.3

Flange mounting

For splined couplings apply proper lubricants.

To machine the driven shaft, please refer to the dimensions shown in ch. 4, catalog EP series.

Before mounting, pay attention to clean carefully mating surfaces.

In presence of external radial loads or torque required $M_2 \geq 0,7 \times M_{N2}$, apply locking adhesives.

Tighten the screws according to the values given in the table on previous page.

To machine the matching frame, please refer to the drawings below.

Sizes 001A ... 021A

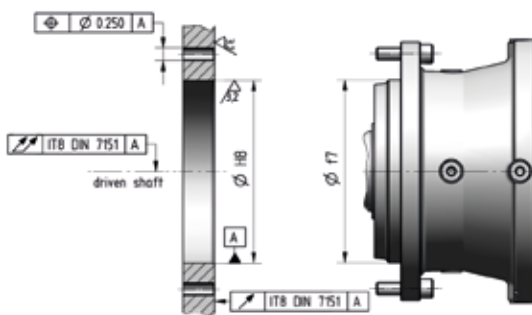

Sizes 030A ... 710A

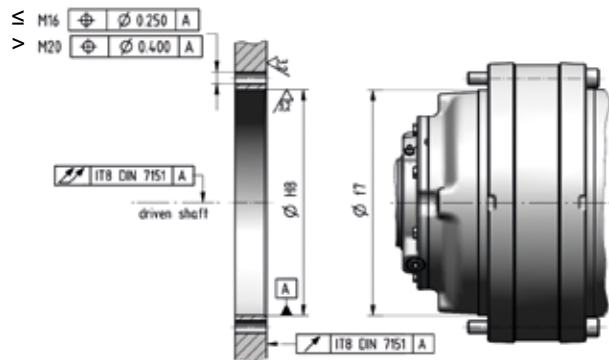

Only for sizes sizes 022A, 031A, 043A

These sizes of gear reducers have two spigots. If the output shaft is not subject to radial load or if radial load is below 60% maximum allowed, the bigger spigot only may be used.

If elastic pins are present on the gear reducer flange, they must be used in the matching with a machine frame by a length equivalent to their diameter.

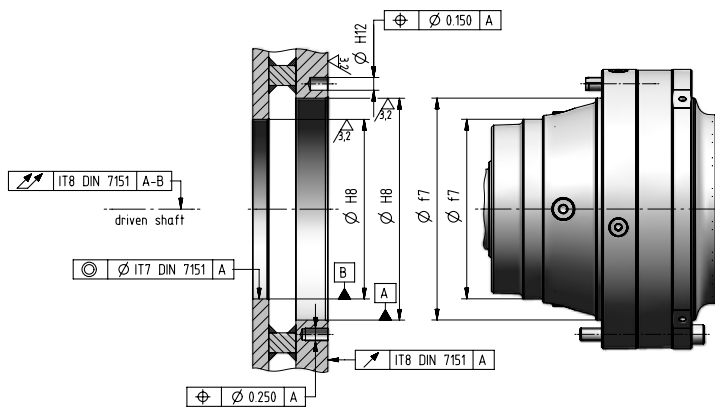

Gear reducer mounting with slewing outputs

In case of gear reducers with slewing outputs (output design R-S-H), in order to assure a correct running and an excellent power transfer between gear reducer and machine, the gear reducer requires a rigid connection structure withstanding the radial loads. The position and shape tolerances stated below are to be observed.

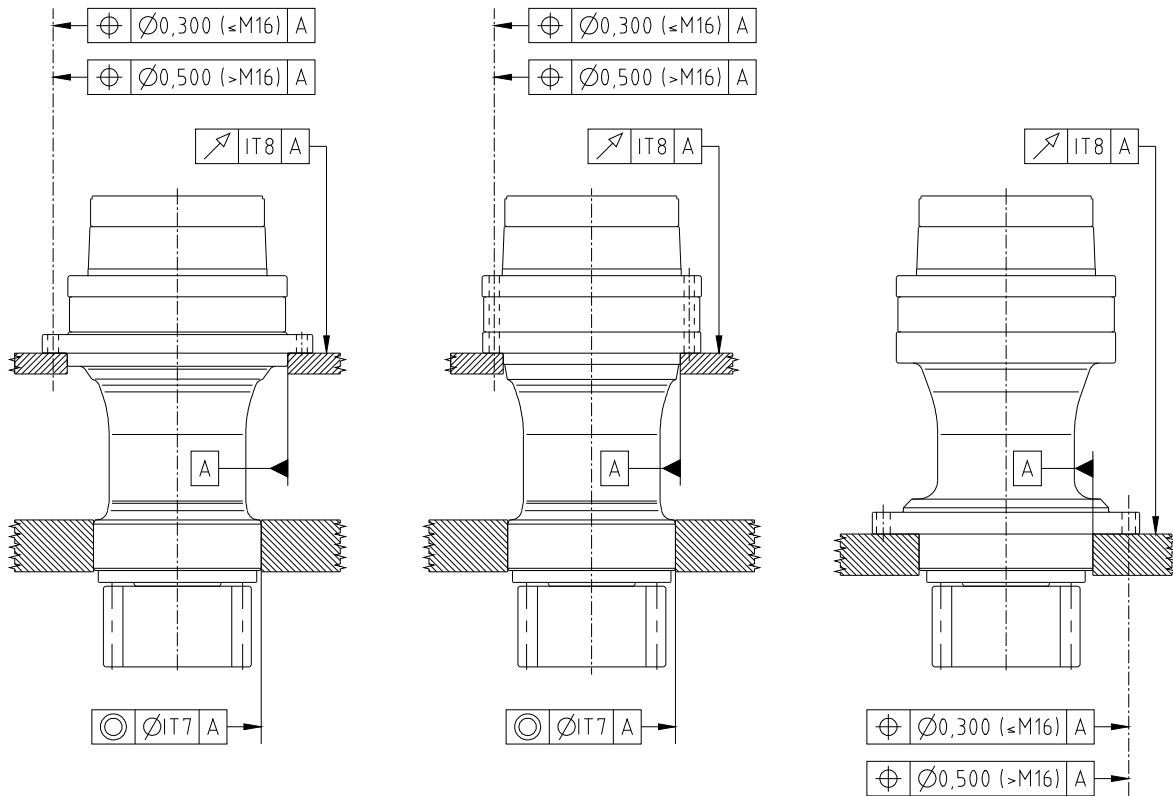

Foot mounting

Sizes 001A ... 021A

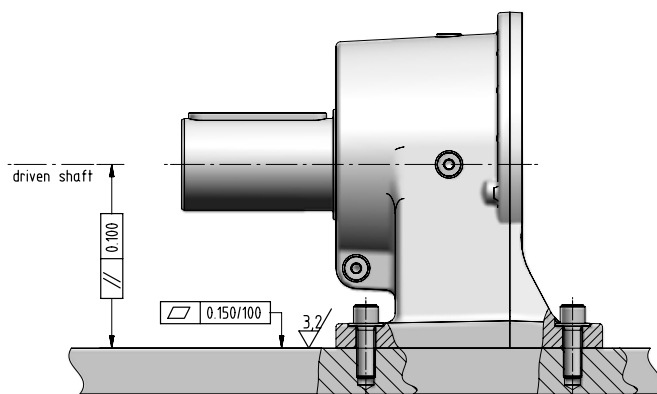

Sizes 030A ... 710A

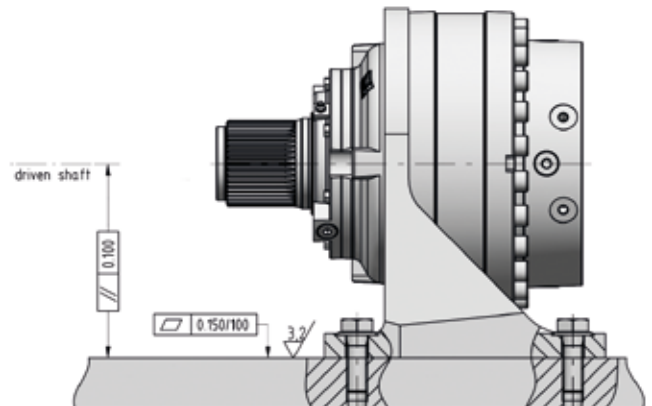

5.6

Shaft mounting arrangements

When shaft mounted, the gear reducer must be supported both axially and radially (also for mounting positions B5 ... B53 see ch. 6) by the shaft end of the driven machine as well as anchored against rotation only by means of a reaction having freedom of axial movement and sufficient clearance in its couplings to permit minor oscillations – always in evidence – without provoking dangerous overloads on the gear reducer. It is recommended to use the torque arm symmetrically to the gear reducer low speed shaft because, in this way, the torque reaction is equally distributed on the two constraints without loading the machine bearings. Foresee adequate elastic bushes and lubricate with proper products the hinges and the parts subject to sliding. Regarding the reaction system, follow the instructions contained in the specific technical documentation.



Whenever personal injury or property damage may occur, due to falling or projecting parts of the gear reducer or of its parts, foresee adequate supplementary protection devices against:

- rotation or unthreading of the gear reducer from shaft end of driven machine following to accidental breakage of the reaction arrangement
- accidental breakage of shaft end of driven machine



Attention! For **vertical ceiling-type** mounting and only for gear reducers equipped with locking rings or bush, gear reducer support is due only to friction, for this reason it is advisable to provide it with a fastening system.

5.7

Torque arm

Asymmetrical torque arm without spherical plain bearing (size 001+021)

Torque arm can be applied indiscriminately to all **H**, **M** and **N** designs. Symmetrical torque arm is provided as standard option (,TA - up to size 085A); if you need a one sided torque arm, it must comply with the dimensions shown below.

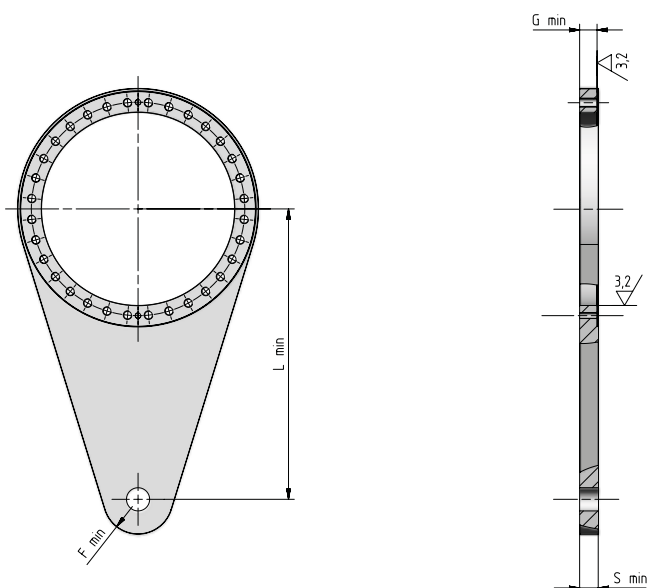

Size	L _{min}	G _{min}	S _{min}	F _{min}	kg
001A	325	10	15	20	3
002A	325	10	15	20	3
003A	375	13	15	20	4
004A	375	13	15	20	4
006A	375	13	15	20	4
009A	450	18	20	30	8
012A	450	18	20	30	8
015A	450	18	20	30	8
018A	550	23	25	35	16
021A	550	23	25	35	16

Asymmetrical torque arm with spherical plain bearing (size 030-710)

H and **M** output designs can be considered with rigid shaft fastening.

T type outputs are to be considered less rigid as a consequence of splined shaft connection and mounting backlash.

H and **M** outputs are to be preferred only when following conditions are met:

- shaft mounting where gear reducer is supporting overhanging masses, e.g. EP+G+motor combined units and eventual accessories on support base, and with high bending moments
- applications where you want to reduce the backlash value to a minimum
- in presence of heavy operating conditions, frequent reversals, dusty and particularly aggressive environments
- high reliability over the years

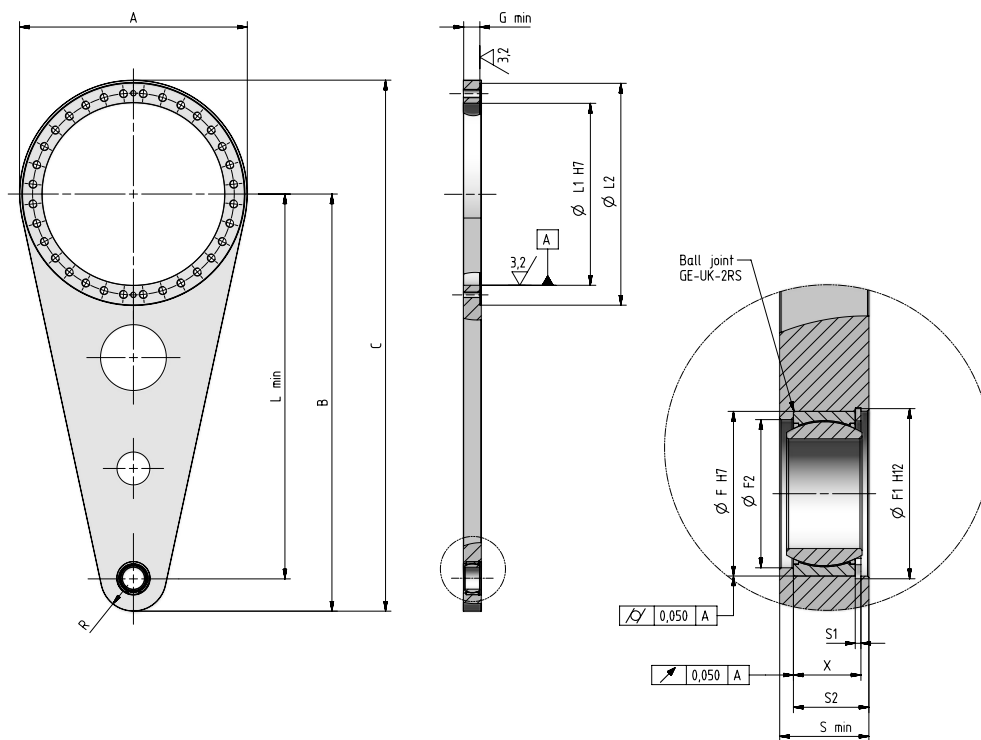

Size	L _{min}	B	A	C	R	G _{min}	S _{min}	S1	S2	X	F	F1	F2	L1	L2	kg
030	600	655	360	835	55	28	30	2,15	25	22,2	47	58	54	285	354	28
042	700	762	420	972	62	33	35	2,15	28,5	24,2	62	65	54	340	412	43
060	800	862	455	1 089,5	62	33	35	2,15	28,5	24,2	62	65	54	365	447	56
085	900	968	520	1 228	68	38	40	2,65	32,5	27,7	68	71	62	425	510	77
125	1 000	1 075	585	1 367,5	75	41	45	2,65	36,5	30,7	75	78	67	470	572	113
180	1 100	1 190	645	1 512,5	90	45	50	3,15	39,2	43	90	93,5	82	520	633	145
250	1 250	1 355	730	1 720	105	55	60	4,15	50	44,2	105	109	95	585	718	235
355	1 400	1 520	830	1 935	120	60	65	4,15	55	49,2	120	124	108	665	810	315
500	1 550	1 680	910	2 135	130	65	70	4,15	60	54,2	130	134	120	730	890	410
710	1 700	1 850	1 000	2 350	150	75	80	4,15	67,5	59,2	150	155	135	810	977	562

Asymmetrical torque arm foot

Here below are the recommended dimensions for the torque arm ground connection brackets.
Customized solutions on request.

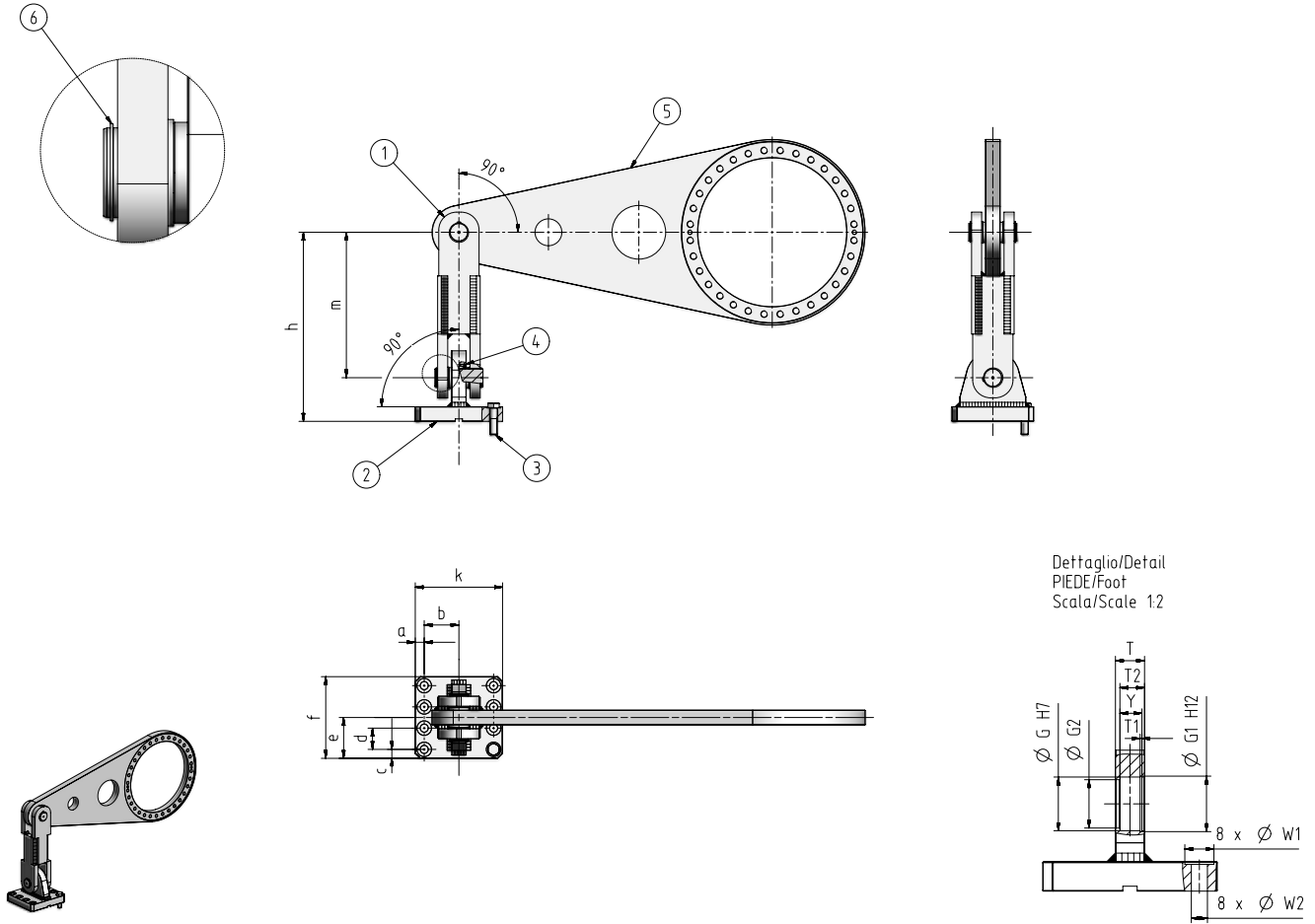

Dettaglio/Detail
PIEDE/Foot
Scala/Scale 1:2

Item	Description
1	Connection Rod
2	Foot
3	Screw UNI 5739
4	Spherical plain bearing GE-UK-2RS
5	Torque Arm
6	Circlip DIN 7435

Size	m	h	c	d	e	f	a	b	k	G	G1	G2	W1	W2	Screw	T1	T2	T	Y
030	250	340	25	45	92,5	185	25	67,5	185	55	58	47	38	20	M18 10,9 - 8x	2,15	25	30	22,2
042	295	400	27,5	55	110	220	27,5	80	215	62	65	54	45	24	M22 10,9 - 8x	2,15	28,5	35	24,2
060	315	420	27,5	55	110	220	27,5	80	215	62	65	54	45	24	M22 10,9 - 8x	2,15	28,5	35	24,2
085	360	480	30	60	120	240	30	92,5	245	68	71	62	50	26	M24 10,9 - 8x	2,65	32,5	40	27,7
125	400	535	35	62,5	128,75	257,5	32,5	102,5	270	75	78	67	55	30	M27 10,9 - 8x	2,65	36,5	45	30,7
180	485	645	37,5	75	150	300	37,5	122,5	320	90	93,5	82	65	33	M30 10,9 - 8x	3,15	43	50	39,2
250	560	740	40	90	175	350	40	140	360	105	109	95	65	36	M33 10,9 - 8x	4,15	50	60	44,2
355	650	845	40	95	182,5	365	40	155	390	120	124	108	65	36	M33 10,9 - 8x	4,15	55	65	49,2
500	725	948,5	50	110	215	450	50	175	450	130	134	120	80	42	M39 10,9 - 8x	4,15	60	70	54,2
710	800	1050	52,5	125	240	480	55	195	500	150	155	135	85	45	M42 10,9 - 8x	4,15	67,5	80	59,2

Dynamic torque arm assembly for system flexibility

Torque arm with double fulcrum and torsion bar fixed to the ground, allows the gear reducer to follow the driven shaft movements during operation and offers an elastic reaction able to absorb the overloads of moment twisting.

The allowed displacement values are shown in the figure, are a function of the quantities and must be checked during accessory selection.

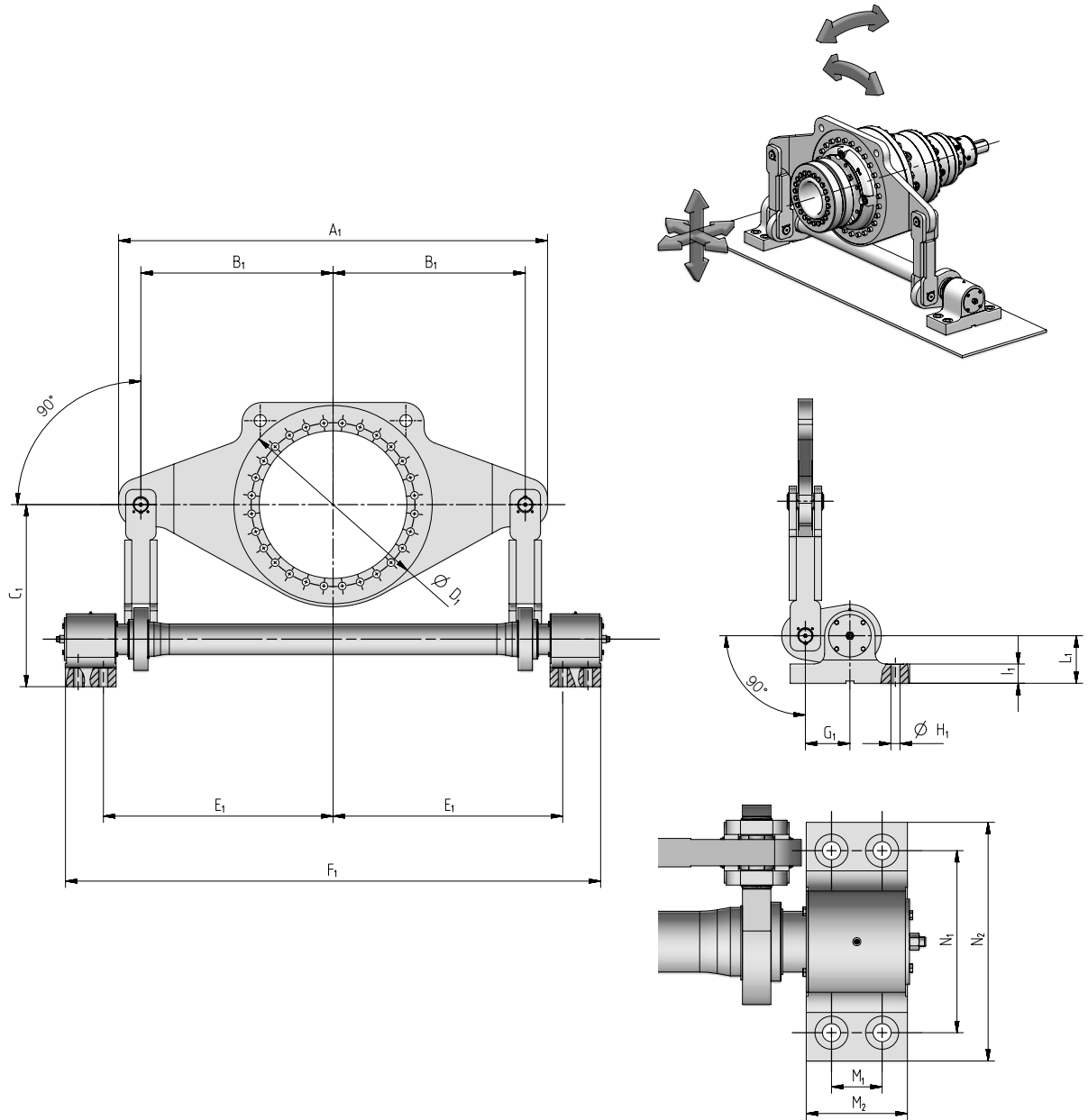

Size	A ₁	B ₁	C ₁	D ₁	E ₁	F ₁	G ₁	H ₁	I ₁	L ₁	M ₁	M ₂	N ₁	N ₂
250	1670	750	700	730	888.5	2041	165	39	55	170	84	180	157.5	157.5
355	1870	850	860	820	1000	2300	175	45	80	195	100	200	350	450
500	2120	950	900	880	1135	2645	220	45	70	229	125	250	450	590
710	2346	1063	1060	980	1248	2871	220	45	95	235	125	250	450	590

5.8

Shaft end mounting

Before mounting clean mating surface thoroughly and lubricate against seizure and fretting corrosion, except for hollow shaft mounting (see below).

For shaft end type **M**, **S + WF**, **T + WT** use screws and tightening torques as shown at page 8.9.



Attention! Installing and removal operations should be carried out with **pullers** and **jacking screws** using the tapped holes at the shaft butt-end (see ch. «Fitting of components to shaft end») taking care to avoid impacts and shocks which may irretrievably damage the bearings, the circlips or other parts.

5.9

Hollow shaft mounting with shrink disc

For the shaft end detail of machines where the hollow shaft of the gear reducer is to be keyed, follow the instructions see EP catalog.

Installation

If the shrink disc is not supplied by us, please carefully follow the manufacturer's instructions

When keying the shrink disc supplied by Rossi, follow these instructions:

- carefully degrease the surfaces of hollow shaft and shaft end of driven machine to be fitted
- mount the shrink disc on gear reducer hollow shaft by lubricating first only the external surface of hollow shaft; pay attention to locate axially the shrink disc at dimension «Q» shown in table below (values valid only for our shrink disc)
- slightly tighten a first group of three screws positioned at about 120° as shown for example in the figure

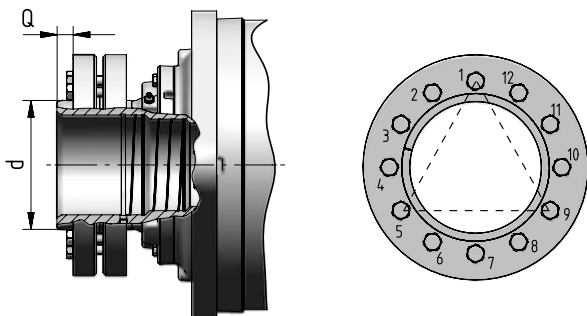
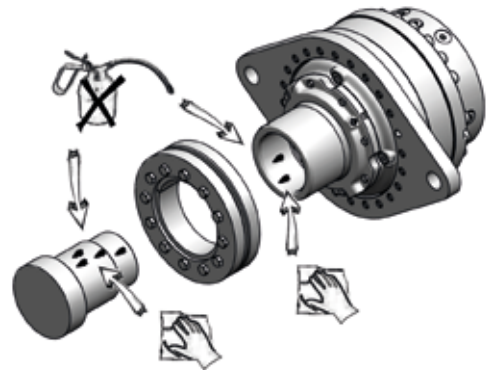

Size	d	Q	Size	d	Q
001A	55	8	042A	165	10
002A	62	8	060A	185	10
003A	68	10	085A	200	10
004A	80	15	125A	240	13,5
006A	90	8	180A	260	13
009A	100	14	250A	300	16
012A	115	13	355A	340	15
015A	120	13	500A	360	15
015A	125	18	710A	420	15
018A	130	13			
021A	130	13			
030A	155	10			

- mount the gear reducer on the machine shaft end; insert the shaft slowly to allow an air escape (from size 030A, open the plug located on the shaft, see below)

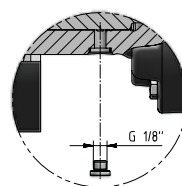
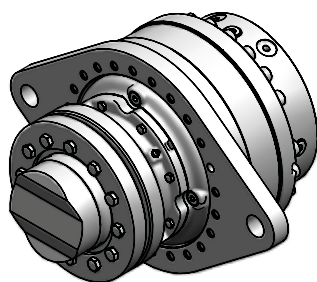

details

- gradually and uniformly tighten, by means of dynamometric wrench, the screws of shrink disc at torque value shown in the fig. below, by a continuous sequence (not crossing) using approximately ¼ turns for several passes until ¼ turns can no longer be achieved
- continue to apply overtorque for 1 or 2 more passes and at the end verify the bolt tightening torque
- when having heavy duty cycles, with frequent reversals, verify the bolt tightening torque again, after some hours of running

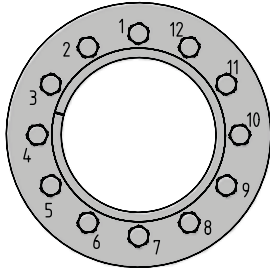

Size	Code	screw	quantity	T... tightening [N m]
001A	SD055	M6	8	12
002A	SD062	M8	6	30
003A	SD068	M8	6	30
004A	SD080	M8	8	30
006A	SD090	M8	10	30
009A	SD100	M8	12	30
012A	SD115	M10	10	59
015A	SD120	M10	12	59
015A	SD125	M12	12	100
018A	SD130	M12	10	100
021A	SD130	M12	10	100
030A	SD155	M12	15	100

Size	Code	screw	quantity	T... tightening [N m]
042A	SD165	M16	10	250
060A	SD185	M16	15	250
085A	SD200	M16	15	250
125A	SD240	M20	15	490
180A	SD260	M20	18	490
250A	SD300	M20	22	490
355A	SD340	M24	20	840
500A	SD360	M24	22	840
710A	SD420	M24	30	840

Dismounting



Do not completely remove fastening screws before locking rings are disengaged.

Risk of serious injury!!!

Clean off any rusty areas.

Loosen the fastening screws one after the other **only** by using approx. ½ turn at a time and by a continuous sequence (not crossing), until shrink disc can be moved on the hollow shaft.

Remove the customer shaft or the gear reducer. For sizes above 030A to make it easier is possible to inject low pressure oil through a threaded hole located on the hollow shaft (see below).

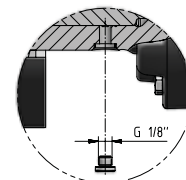
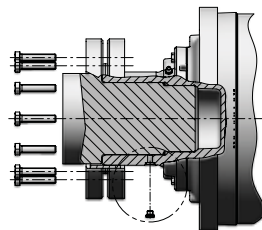
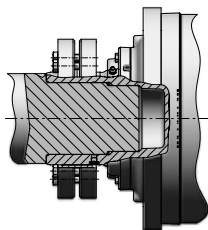

detail

"T" outputs can be used both for gear reducer shaft mounting coupling it to the splined solid shaft and coupling it to a splined solid wheel flange.

For the mounting of "T" output to a splined solid wheel flange, carefully follow these instructions:

- remove the metal plugs positioned on splined wheel flange holes, prearranged for the fastening screws
- carefully lubricate the splined parts with grease for industrial applications with heavy and long lasting loads
- insert the O-ring seal on flange shaft
- (in case of mounting with wheel flange) - orientate the accessory before mounting; identify the tooth of splined shaft timing with the relevant recess positioned on gear reducer shaft. Timed tooth and recess are identified as per hole, see fig.
- insert slowly the splined shaft in order to have an air outlet
- radially mount the cover, compressing the O-ring
- screw with crossed tightening the tightening screws of half rings taking care to tighten to the relevant torque
- close the holes of splined wheel flange with plugs

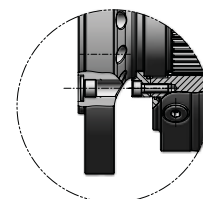
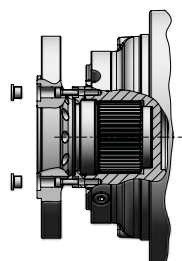
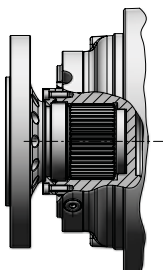

In case of output N, follow the instructions below:

Installation

- remove the key on the machine shaft end (number 7).
- arrange the o-ring and ring (number 2) on the machine shaft between key seat and circular recess for axial lock. Arrange o-ring into the ring seat
- install the key on the driven shaft end and spread Klüberpaste MR401(or similar) on the driven shaft end.
- install the gearbox (number 1) over the entire length of the keyway taking care to have the space to install the half lock rings
- Insert the half lock rings (number 3) into the machine shaft end recess on the machine shaft end. Put together with ring (number 2) with UNI 5931 short screws (number 4) and UNI 5739 medium length screws. Slightly tighten a first group of three screws positioned at about 120 °. Gradually and uniformly tighten the screws by means of dynamometric wrench.
- Lock system are placed and no axial movement must be observed, otherwise check components dimension or contact Rossi S.p.A. before other step.
- after axial lock check (as above), assemble gear reducers with the lock system using UNI 5739 long screws according to screws type and class tightening torque. Slightly tighten a first group of three screws positioned at about 120 °. Gradually and uniformly tighten the screws by means of dynamometric wrench.

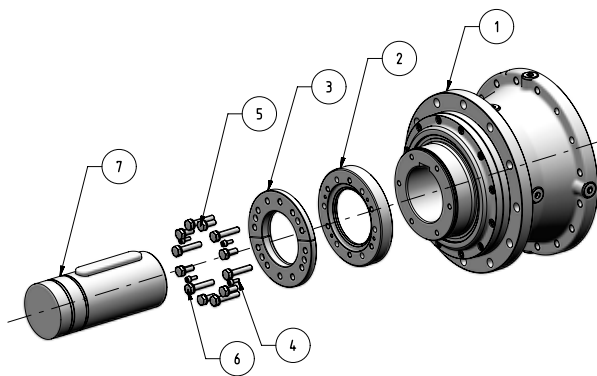

Pos.	Description
1	Gearbox
2	Ring with o-ring seal
3	Half rings
4	UNI 5931 Screw
5	UNI 5739 short screw
6	UNI 5739 long screw
7	Driven shaft end

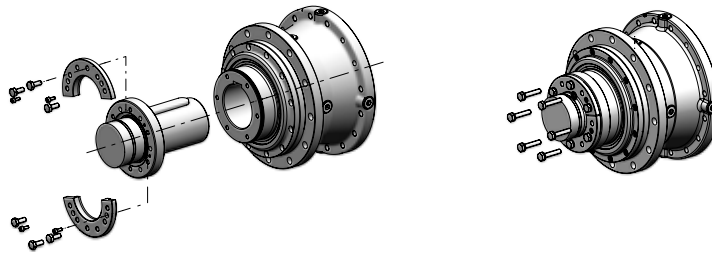

Dismounting

- Clean all oxidized areas
- Remove all UNI 5739 fixing screws.
- Insert UNI 5739 long screws into the holes previously occupied by UNI 5739 the medium length screws and use them as an extractor to dismount the gear reducer from the driven shaft.

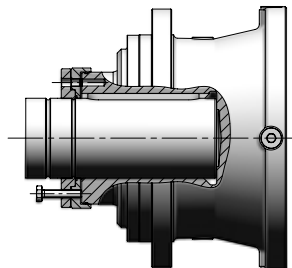

Accessories mounting

Carefully clean the coupling surfaces, apply locking adhesives (recommended only with torque arm or foot bracket) and assemble the accessory to the gear reducer. Tighten the screws by a dynamometric wrench at values shown in the following tables.

Torque arm

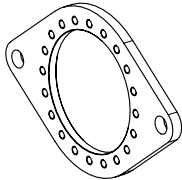

Code	screw			tightening torque [Nm]
	d x l	class	ISO	
TA10a	M10x25	10.9	4762	70
TA10b	M12x30	10.9	4762	120
TA10c	M14x40	10.9	4762	190
TA10d	M14x50	10.9	4762	190
TA10e	M16x150	10.9	4762	300
TA10f	M16x160	10.9	4762	300
TA10g	M20x180	10.9	4762	560
TA10h	M20x200	10.9	4762	560

Foot bracket

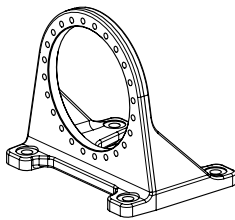

Code	screw			washer	tightening torque [Nm]
	d x l	class	ISO	DIN	
FB10e	M16x150	10.9	4762	-	300
FB10f	M16x160	10.9	4762	-	300
FB10g	M20x180	10.9	4762	-	560
FB10h	M20x200	10.9	4762	-	560
FB10i	M24x220	10.9	4014	6916	1000
FB10j	M24x240	10.9	4014	6916	1000
FB10k	M30x280	10.9	4014	6916	1950
FB10l	M30x320	10.9	4014	6916	1950
FB10m	M36x340	10.9	4014	6916	3550
FB10n	M36x380	10.9	4014	6916	3550

Stop washer



Code	screw			washer	tightening torque [Nm]
	d x l	class	ISO	DIN	
SW040	M6x16	8.8	4017	-	11
SW045	M6x16	8.8	4017	-	11
SW050	M8x20	8.8	4017	-	25
SW058	M10x25	8.8	4017	-	50
SW062	M10x25	8.8	4017	-	50
SW070	M10x25	8.8	4017	-	50
SW080	M12x30	8.8	4017	-	85
SW090	M14x35	8.8	4017	-	135
SW100	M14x40	10.9	4017	6916	190
SW120	M16x40	10.9	4017	6916	300
SW130	M16x40	10.9	4017	6916	300
SW150	M16x40	10.9	4017	6916	300
SW170	M16x50	10.9	4017	6916	300
SW200	M20x60	10.9	4017	6916	560
SW220	M20x65	10.9	4017	6916	560
SW240	M24x70	10.9	4017	6916	1000
SW280	M27x80	10.9	4017	6916	1400
SW300	M30x90	10.9	4017	6916	1950

Fitting of components to shaft end

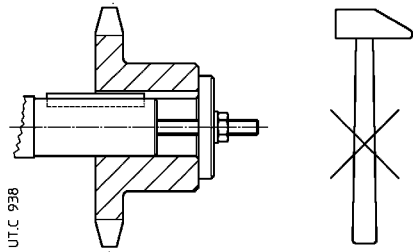

It is recommended that the bore of parts keyed to cylindrical shaft ends (spigots for splined shaft ends) is machined as indicated in EP catalog. Before mounting, clean mating surfaces thoroughly and lubricate against seizure and fretting corrosion. Attention! Installing and removal operations should be carried out with pullers and jacking screws using the tapped holes at the shaft butt-end (see fig. below) taking care to avoid impacts and shocks which may irretrievably damage the bearings, the circlips or other parts. For H7/m6, K7/k6 and K7/m6 fits it is advisable that the part to be keyed is preheated to a temperature of $80 \pm 100 \text{ }^\circ\text{C}$.

For splined couplings apply adequate grease or paste. The couplings having a tip speed on external diameter up to 20 m/s must be statically balanced; for higher tip speeds they must be dynamically balanced.

Where the transmission link between gear reducer and machine or motor generates shaft end loads, (see fig. below), ensure that the loads do not rise above the catalog values:

- transmission overhang is kept to a minimum
- gear-type transmission must guarantee a minimum of backlash on all mating flanks
- drive-chains should not be tensioned (if necessary – alternating loads and/or motion – foresee suitable chain tighteners)
- drive-belts should not be over-tensioned

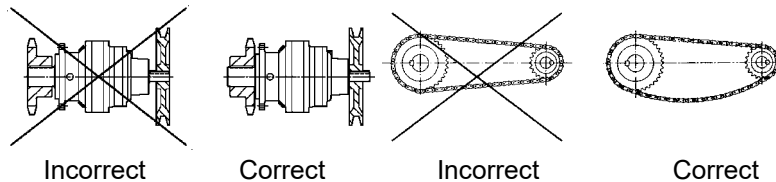

Pinion gear

When a pinion gear is mounted on output shaft, you must check the value of backlash with the corresponding slewing bearing or rack to achieve a correct meshing (see below).

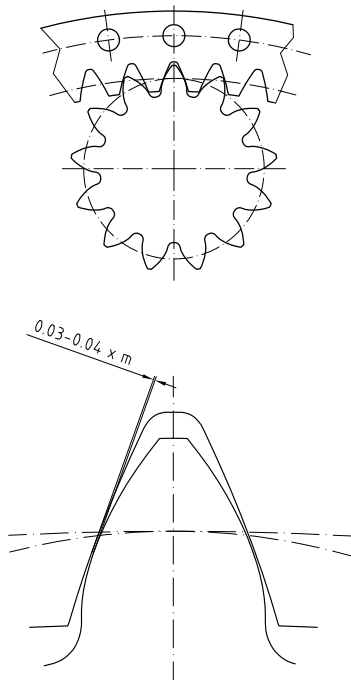

Code	m	z	α	x	d_a	d_f	k	Wk	Tolerance range	
R002CA	8	11	20	0,5	109,5	77,33	2	39,394	-0,038	-0,076
R002BB	6	12	20	0,5	89,5	64,00	3	47,342	-0,034	-0,068
R002BC	6	13	20	0,5	95,5	70,00	3	47,427	-0,034	-0,068
R002BD	6	14	20	0,5	101,5	76,00	3	47,511	-0,034	-0,068
R002BE	6	15	20	0,5	107,5	82,00	3	47,595	-0,034	-0,068
R002AF	5	16	20	0,5	94,5	73,33	3	39,732	-0,034	-0,068
R006DA	10	11	20	0,5	139	96,67	2	49,243	-0,038	-0,076
R006DB	10	12	20	0,5	149	106,67	3	78,904	-0,038	-0,076
R006CC	8	13	20	0,5	127	93,33	3	63,235	-0,038	-0,076
R006CD	8	14	20	0,5	135	101,33	3	63,347	-0,038	-0,076
R006CE	8	15	20	0,5	143	109,33	3	63,459	-0,038	-0,076
R006CF	8	16	20	0,5	149,5	117,33	3	63,571	-0,041	-0,082
R012FA	14	11	20	0,5	194,5	135,33	2	68,940	-0,047	-0,094
R012EB	12	12	20	0,5	179	128,00	3	94,685	-0,047	-0,094
R012EC	12	13	20	0,5	191	140,00	3	94,853	-0,047	-0,094
R012DD	10	14	20	0,5	169	126,67	3	79,184	-0,041	-0,082
R012DE	10	15	20	0,5	179	136,67	3	79,324	-0,041	-0,082
R012DF	10	16	20	0,5	189	146,67	3	79,464	-0,041	-0,082
R018GA	16	11	20	0,5	222,5	154,67	2	78,788	-0,047	-0,094
R018FB	14	12	20	0,5	208,5	149,33	3	110,466	-0,047	-0,094
R018FC	14	13	20	0,5	222,5	163,33	3	110,662	-0,047	-0,094
R018ED	12	14	20	0,5	203	152,00	3	95,021	-0,047	-0,094
R018EE	12	15	20	0,5	215	164,00	3	95,189	-0,047	-0,094
R018EF	12	16	20	0,5	227	176,00	3	95,357	-0,047	-0,094

Note: Definitions according to DIN 3960.

Splined shaft greasing

When pinion is supplied separately from gear reducer, before keying it onto shaft, lubricate the splined shaft with anti-corrosion grease in order to avoid any contact corrosion process. Do this operation at the first commissioning, only.

Meshing clearance adjustment

In the presence of eccentric centering, the meshing action between pinion and rack is regulated through the rotation of the gear reducer inside its seat on the machine.

The point of maximum eccentricity of the centering is given by a small hole or a small milling obtained on the outlet support.

To adjust the meshing clearance, it is advisable to place itself in the initial minimum clearance condition, which can be obtained by making the point of maximum eccentricity on the gear reducer face:

- towards the center of the rack in case of **internal gear**;
- at 180° with respect to the center of the rack in case of **external gear**.

In this condition the meshing clearance must not be less than **0,03 ÷ 0,04 x m**.

It is also advisable that the measured clearance is in the range recommended by the rack manufacturer.

It is advisable to measure the clearance using calibrated thicknesses.

For the lubrication of pinion and rack, use only high quality grease suitable for the lubrication of gears subjected to high loads such as GADUS S5 T460 1.5 Shell.

Suggested mating tolerances

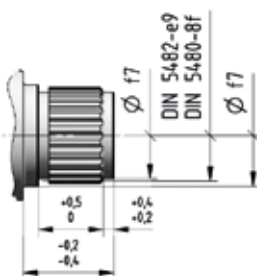
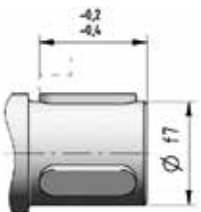
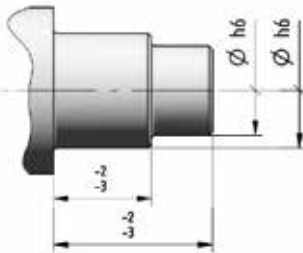
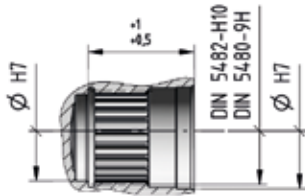
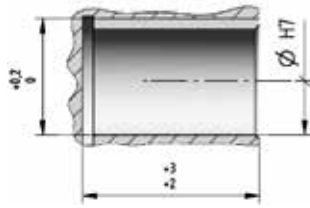

Output

Gear reducer shaft end tolerances

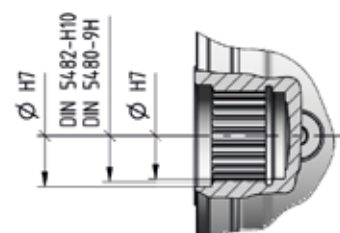
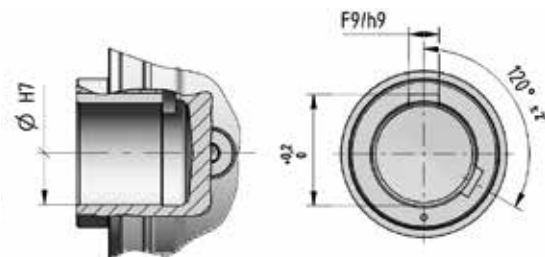
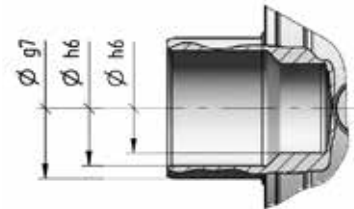
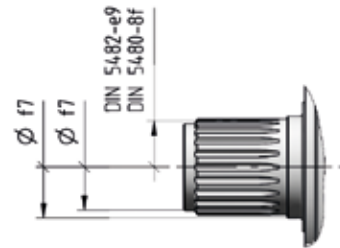
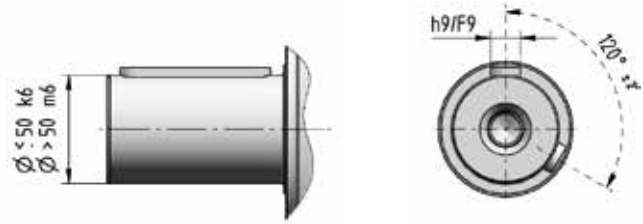

Tolerances according to ISO 286

mm	e7	f7	g6	g7	h6	h9	k6	m6	E6	F6	F9	G7	H6	H7	J7	
from	1	-0,014	-0,006	-0,002	-0,002	0	0	+0,006	+0,008	+0,020	+0,012	+0,031	+0,012	+0,006	+0,010	+0,004
to	3	-0,024	-0,016	-0,008	-0,012	-0,006	-0,025	0	+0,002	+0,014	+0,006	+0,006	+0,002	0	0	-0,006
>	3	-0,020	-0,010	-0,004	-0,004	0	0	+0,009	+0,012	+0,028	+0,018	+0,040	+0,016	+0,008	+0,012	+0,006
to	6	-0,032	-0,022	-0,012	-0,016	-0,008	-0,030	+0,001	+0,004	+0,020	+0,010	+0,010	+0,004	0	0	-0,006
>	6	-0,025	-0,013	-0,005	-0,005	0	0	+0,010	+0,015	+0,034	+0,022	+0,049	+0,020	+0,009	+0,015	+0,008
to	10	-0,040	-0,028	-0,014	-0,020	-0,009	-0,036	+0,001	+0,006	+0,025	+0,013	+0,013	+0,005	0	0	-0,007
>	10	-0,032	-0,016	-0,006	-0,006	0	0	+0,012	+0,018	+0,043	+0,027	+0,059	+0,024	+0,011	+0,018	+0,010
to	18	-0,050	-0,034	-0,017	-0,024	-0,011	-0,043	+0,001	+0,007	+0,032	+0,016	+0,016	+0,006	0	0	-0,008
>	18	-0,040	-0,020	-0,007	-0,007	0	0	+0,015	+0,021	+0,053	+0,033	+0,072	+0,028	+0,013	+0,021	+0,012
to	30	-0,061	-0,041	-0,020	-0,028	-0,013	-0,052	+0,002	+0,008	+0,040	+0,020	+0,020	+0,007	0	0	-0,009
>	30	-0,050	-0,025	-0,009	-0,009	0	0	+0,018	+0,025	+0,066	+0,041	+0,087	+0,034	+0,016	+0,025	+0,014
to	50	-0,075	-0,050	-0,025	-0,034	-0,016	-0,062	+0,002	+0,009	+0,050	+0,025	+0,025	+0,009	0	0	-0,011
>	50	-0,060	-0,030	-0,010	-0,010	0	0	+0,021	+0,030	+0,079	+0,049	+0,104	+0,040	+0,019	+0,030	+0,018
to	80	-0,090	-0,060	-0,029	-0,040	-0,019	-0,074	+0,002	+0,011	+0,060	+0,030	+0,030	+0,010	0	0	-0,012
>	80	-0,072	-0,036	-0,012	-0,012	0	0	+0,025	+0,035	+0,094	+0,058	+0,123	+0,047	+0,022	+0,035	+0,022
to	120	-0,107	-0,071	-0,034	-0,047	-0,022	-0,087	+0,003	+0,013	+0,072	+0,036	+0,036	+0,012	0	0	-0,013
>	120	-0,085	-0,043	-0,014	-0,014	0	0	+0,028	+0,040	+0,110	+0,068	+0,143	+0,054	+0,025	+0,040	+0,026
to	180	-0,125	-0,083	-0,039	-0,054	-0,025	-0,100	+0,003	+0,015	+0,085	+0,043	+0,043	+0,014	0	0	-0,014
>	180	-0,100	-0,050	-0,015	-0,015	0	0	+0,033	+0,046	+0,129	+0,079	+0,165	+0,061	+0,029	+0,046	+0,030
to	250	-0,146	-0,096	-0,044	-0,061	-0,029	-0,115	+0,004	+0,017	+0,100	+0,050	+0,050	+0,015	0	0	-0,016
>	250	-0,110	-0,056	-0,017	-0,017	0	0	+0,036	+0,052	+0,142	+0,088	+0,186	+0,069	+0,032	+0,052	-0,036
to	315	-0,162	-0,108	-0,049	-0,069	-0,032	-0,130	+0,004	+0,020	+0,110	+0,056	+0,056	+0,017	0	0	-0,016
>	315	-0,125	-0,062	-0,018	-0,018	0	0	+0,040	+0,057	+0,161	+0,098	+0,202	+0,075	+0,036	+0,057	+0,039
to	400	-0,182	-0,119	-0,054	-0,075	-0,036	-0,140	+0,004	+0,021	+0,125	+0,062	+0,062	+0,018	0	0	-0,018
>	400	-0,135	-0,068	-0,020	-0,018	0	0	+0,045	+0,063	+0,165	+0,102	+0,223	+0,083	+0,040	+0,063	+0,043
to	500	-0,198	-0,131	-0,060	-0,081	-0,040	-0,155	+0,005	+0,023	+0,125	+0,062	+0,068	+0,020	0	0	-0,020

Splined shafts - measurement over pins

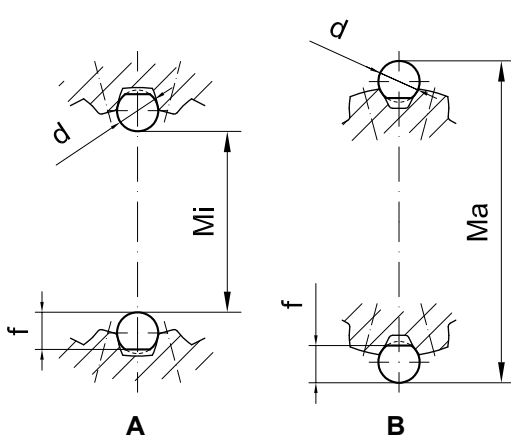

DIN 5482	female male	m	z	d pin	f pin	tolerance	Mi - Ma	
							max	min
40x36	A	1,9	20	3,5	3,2	H10	32,712	32,612
	B			3,5	-	e9	43,281	43,235
45x41	A	2	22	4	3,6	H10	36,709	36,610
	B			3,5	-	e9	48,631	48,591
50x45	A	2	24	3,5	3,2	H10	42,515	42,433
	B			3,5	-	e9	52,635	52,594
58x53	A	2	27	3,5	-	H10	49,967	49,881
	B			3,5	-	e9	59,818	59,772
62x57	A	2,1	29	4	3,7	H10	53,405	53,317
	B			3,5	-	e9	64,700	64,657
70x64	A	2,1	32	4	-	H10	60,673	60,577
	B			4	-	e9	73,198	73,150
80x74	A	2,1	36	4	-	H10	70,815	70,730
	B			4	-	e9	83,064	83,018
90x84	A	2,25	40	3,5	-	H10	81,651	81,564
	B			4	3,7	e9	92,198	92,151
100x94	A	2,25	44	3,5	-	H10	91,875	91,796
	B			4	3,7	e9	102,245	102,201

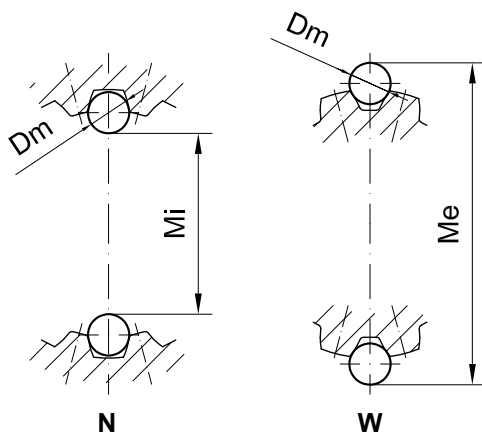

DIN 5480	female male	m	z	Dm	tolerance	Mi - Me	
						max	min
120x3	N	3	38	5,5	9H	108,517	108,420
	W			6	8f	126,017	125,957
130x3	N	3	42	5,5	9H	118,466	118,365
	W			6	8f	136,248	136,185
150x5	N	5	28	10	9H	128,243	128,129
	W			10	8f	159,876	159,810
170x5	N	5	32	10	9H	148,247	148,134
	W			11	8f	182,675	182,609
200x5	N	5	38	10	9H	178,252	178,140
	W			11	8f	212,812	212,745
220x5	N	5	42	10	9H	198,276	198,150
	W			11	8f	232,874	232,799
240x5	N	5	46	10	9H	218,278	218,152
	W			11	8f	252,938	252,862
280x8	N	8	34	15	9H	247,640	247,500
	W			16	8f	296,909	296,830
300x8	N	8	36	15	9H	268,026	267,896
	W			16	8f	316,563	316,485

For more detail see specific literature DIN 5482 or DIN 5480.

Universal flange adapter

The universal input flange allows the customers to make their flanges and couplings suitable for the main motorization types. It's very important to observe the information shown in the drawing below to obtain a correct gear reducer oil sealing. The universal input flange can be used for motors up to 1 000 Nm maximum torque and weight as per following chart.

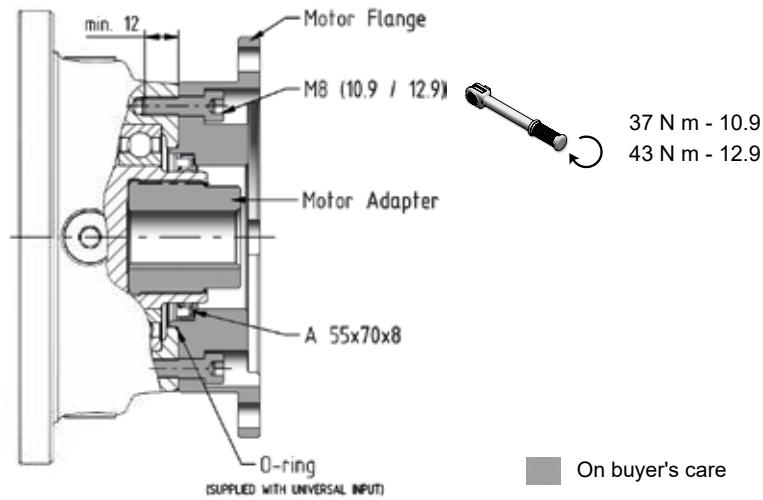

Gearboxes with “U” input (not “UN” and “UH”) are supplied with an additional cover as shown below. When a flange made by customer have to be used, please remove it.



Pay attention for gearboxes supplied with oil. Removing the cover oil may leak.

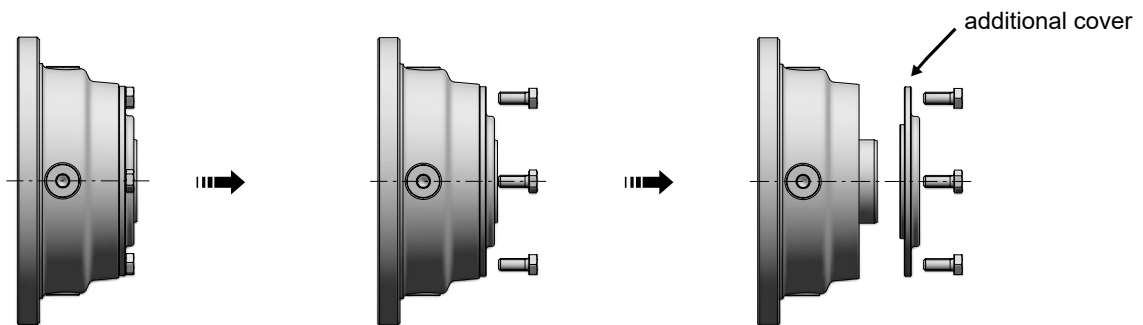

When a universal flange adapter is used, it must be checked if the total weight of the flange+motor and the distance of their center of gravity are compliant with the following diagram. In case of high vibrations or dynamic stress, please contact Rossi S.p.A..



Severe or fatal injury and damage to property may occur.

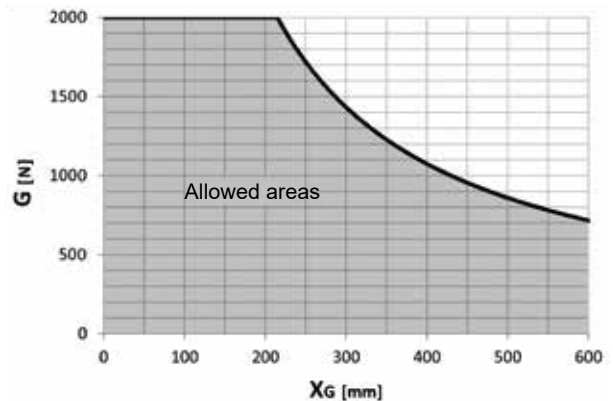
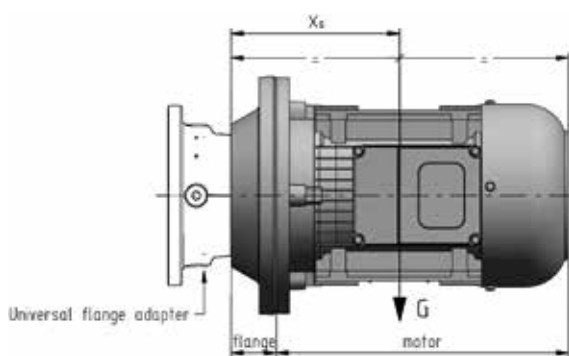

Check the mating dimensions for standards IEC 72-1 be sure that the mating surfaces are machined under accuracy rating (IEC 60072-1, UNEL 13501-69; DIN 42955) – for NEMA standards please refer to NEMA C-FACE chart;

- clean surfaces to be fitted thoroughly;
- check and, if necessary, lower the parallel key so as to leave a clearance of $0,1 \div 0,2$ mm between its top and the bottom of the keyway of the hole. If shaft keyway is without shoulder, lock the key with a pin.
- lubricate surfaces to be fitted against fretting corrosion (Klüberpaste 46 MR 401 is recommended).
- insert the motor down to shoulder on gear reducer flange; this operation can be facilitate vertically positioning the gear reducer with motor flange mounted upwards;



Do not force the motor shaft into the gear reducer coupling. A serious damage may occur!

- check that motor centering is in the relevant gear reducer flange seat
- check that the length of the screws is enough to have $2 \times$ pitch over the nut
- tighten the motor fastening screws to gear reducer flange in order to achieve the tightening torque as per following table:

Bolt	Tightening torque N m class 8.8
d Ø	
M8	25
M10	56
M12	85
M14	135
M16	205

Maximum allowed bending moment

In case of assembly of motors supplied by the customer, verify that the static bending moment M_b generated by motor weight on the counter flange of gear reducer is lower than the value allowed M_{bmax} , stated in the table:

$$M_b < M_{bmax}$$

where:

$$M_b = G \cdot (Y_G + h) / 1\,000 \text{ [N m]}$$

G [N] motor weight, nearly numerically equal to motor mass, expressed in kg, multiplied by 10

Y_G [mm] distance from motor center of gravity from flange surface

h [mm] supplied in the table, according to gear reducer size and IEC motor size

Too long and thin motors, though with bending moments lower than prescribed limits, may generate anomalous vibrations during the operation. In these cases it is necessary to foresee a proper additional motor support (see motor specific documentation).

Loads higher than permissible loads may be present in dynamical applications where the gearmotor is subjected to translations, rotations or oscillations: consult us for the study of every specific case.

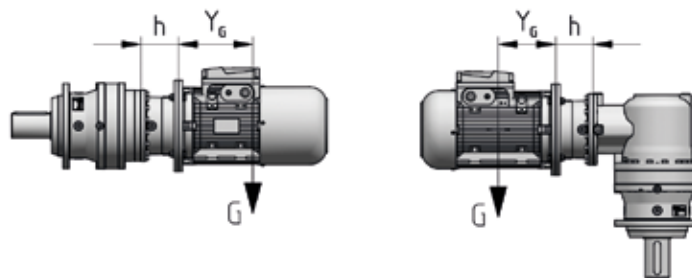

Bending moment M_{bmax} and dimension h

1EL	2EL	3EL	4EL	2EB	3EB	4EB	IEC	Code	h mm	M_{bmax} N m
001A, 002A	001A ... 006A	001A ... 022A	001A ... 061A	001A ... 006A	001A ... 022A	001A ... 061A	71	I14×160	52	900
							80	I19×200	72	
							90	I24×200	72	
							100	I28×250	82	
							112	I28×250	82	
							132	I38×300	102	
							160	I42×350	135	
							180	I48×350	135	
003A ... 006A	009A ... 022A	030A ... 061A	085A ... 180A	009A ... 015A 022A	030A ... 043A	085A ... 125A	100	I28×250	103	2800
							112	I28×250	103	
							132	I38×300	120	
							160	I42×350	153	
							180	I48×350	153	
							200	I55×400	153	
							225	I60×450	183	
009A ... 015A	030A ... 043A	085A ... 125A	250A ... 355A	018A, 021A, 030A	060A, 085A	180A ... 250A	132	I38×300	133,5	4500
							160	I42×350	159	
							180	I48×350	159	
							200	I55×400	159	
							225	I60×450	189	
							250	I65×550	189	
							280	I75×550	189	
018A, 021A	060A-061A	180A	500A	042A ... 061A	125A ... 180A	355A ... 500A	160	I42×350	159	4500
							180	I48×350	159	
							200	I55×400	159	
							225	I60×450	189	
							250	I65×550	189	
							280	I75×550	189	
030A ... 043A	085A ... 125A	250A ... 355A	710A	085A ... 125A	250A ... 355A	710A	160	I42×350	111	4500
							180	I48×350	111	
							200	I55×400	111	
							225	I60×450	141	
							250	I65×550	141	
							280	I75×550	141	

7.2

Hydraulic motors

- check the mating dimensions
- clean surfaces to be fitted thoroughly
- ensure that any seal provided (O-ring) with hydraulic motor is correctly fitted in its seat
- lubricate surfaces to be fitted against fretting corrosion using proper grease or paste
- insert the motor down to shoulder on gear reducer flange; this operation can be facilitated by vertically positioning the gear reducer with motor flange mounted upwards



Do not force the motor shaft into the gear reducer coupling. A serious damage may occur!

- Check that motor centering is in the relevant gear reducer flange seat
- Tighten the motor fastening screws to gear reducer flange in order to achieve the appropriate tightening torque
- Use bolts 8.8 or higher

Gear pairs are oil-bath lubricated, bearings are either oil bathed or splashed or lubricated «for life» with grease. For some mounting positions with continuous duty at high speed, an expansion tank is foreseen: consult us.

Sizes 001A ... 021A: gear reducers are supplied **filled with PAO synthetic oil** having ISO viscosity grade 320 cSt (at 40° C).

Important!: Verify the mounting position, keeping in mind that if gear reducer is installed in a mounting position differing from the one stated on name plate, it could need the addition of the difference between the two lubricant quantities. In any cases, always check the correct oil quantities through the level plug.

Sizes 022A ... 710A: gear reducers are supplied **without oil**; before putting into service, fill to the specified level¹⁾ with synthetic or mineral oil (see table below).

1) The lubricant quantities stated in ch.13 are approximate and indicative for provisioning. The exact oil quantity the gear reducer is to be filled with is definitely given by the level. When output speed n_2 is lower than 0,3 min⁻¹, for all mounting positions please refer to the approximate oil quantities stated for V1 position.

Important:

Inappropriate lubricants can cause damage to the gear reducer. Polyalphaolefin (PAO) base synthetic lubricants must be preferred over Polyglycol (PAG) base synthetic lubricants.

Never mix different type or brand of synthetic oil; if the oil-change involves switching to a different type from the one used so far, then give the gear reducer a through clean-out.

In case of first filling of Polyglycol (PAG) base synthetic lubricant it is mandatory to clean the gear reducer thoroughly before the final filling through a preliminary internal washing to eliminate the residues of any lubricants.

Rossi S.p.A. declines any responsibility deriving from the use of other lubricants or from the use outside the expected ambient temperature range. The indications on lubricants do not bind Rossi S.p.A. on the quality of the lubricant supplied by each respective manufacturer.

Use only lubricants with **EP** (extreme pressure) **additives**.

In case of mineral lubricant choice, follow the instructions about the service factor (EP catalog).

Manufacturer	PAO synthetic oil ISO VG 320	mineral oil ISO VG 150 ... 460	Manufacturer	PAO synthetic oil ISO VG 320	mineral oil ISO VG 150 ... 460
AGIP	Blasia SX	Blasia	KLÜBER	Klübersynth GEM4	Klübersynth GEM1
ARAL	Degol PAS	Degol BG	MOBIL	Mobil SHC Gear	Mobilgear 600 XP
BP	Enersyn EPX	Energol GR-XP	SHELL	Omala S4 GX	Omala S2 G
CASTROL	Alphasyn EP	Alpha SP	TEXACO	Pinnacle	Meropa
FUCHS	Renolin Unisys	Renolin CLP	TOTAL	Carter SH	Carter EP

For lubricant viscosity selection, refer to the table in the next page.

Bearings with independent lubrication

Usually the bearings are automatically and continuously lubricated (oil-bathed or splashed) with the same lubricant of gear reducer. However for certain gear reducer in vertical mounting positions V1, V3 and horizontal mounting positions B51, B52 the upper bearings have independent lubrication, with special grease for «long life» lubrication in absence of external pollution.

Lubrication of PB parking brakes

PB series brakes **require lubrication** and are supplied **without oil**, as specified by the relevant adhesive label.

Before putting the brakes into service fill them with mineral oil ISO VG 32, unless otherwise prescribed by specific documentation. Hydraulic oils are generally suitable.

The separate lubrication prevents premature lubricant contamination in the gear reducer, increasing gears and bearings life.



Lubricant

Lubricant type and viscosity selection according to output speed n_2 [min⁻¹] and ambient temperature T_{amb} [°C] range.

The following tables have been created starting from Shell lubricant characteristics, but are also valid for similar products (see table on page 8.23). For further verification, especially under extreme operating conditions, always refer to the technical data sheet of the specific lubricant.

Splash lubrication or with independent cooling units ¹⁾

	Oil viscosity [cSt @ 40°C]	Ambient temperature T_{amb} [°C]													
		-20	-15	-10	-5	0	+5	+10	+15	+20	+25	+30	+35	+40	+45
Mineral oil	ISO VG 150	$n_2 > 140$													
	ISO VG 220	$2,0 \leq n_2 \leq 140$						$n_2 > 140$						⊘	
	ISO VG 320	⊘			$n_2 < 2,0$						$2,0 \leq n_2 \leq 140$				
	ISO VG 460	⊘			$n_2 < 2,0$										
PAO synthetic oil (Polyalphaolefine)	ISO VG 150	$n_2 > 140$													⊘
	ISO VG 220	$2,0 \leq n_2 \leq 140$						$n_2 > 140$							
	ISO VG 320	⊘			$n_2 < 2,0$						$2,0 \leq n_2 \leq 140$				
	ISO VG 460	⊘			$n_2 < 2,0$										
PAG synthetic oil (Poly Alkylene Glycol)	ISO VG 150	$n_2 > 140$													⊘
	ISO VG 220	$2,0 \leq n_2 \leq 140$						$n_2 > 140$							
	ISO VG 320	⊘			$n_2 < 2,0$						$2,0 \leq n_2 \leq 140$				
	ISO VG 460	⊘			$n_2 < 2,0$										

1) Provide starting of the independent cooling units only when the oil temperature T_{oil} is $> 25^\circ\text{C}$. During the starting, it may take a short period of time for the oil to circulate completely between the unit and the gearbox, depending on the viscosity level and the morphology of pipes and oil connections. During this transitional period, operation of the gear unit is permitted.

Forced lubrication with/without heat exchanger ²⁾

	Oil viscosity [cSt @ 40°C]	Ambient temperature T_{amb} [°C]																
		-20	-15	-10	-5	0	+5	+10	+15	+20	+25	+30	+35	+40	+45	+50		
Mineral oil	ISO VG 150	$n_2 > 140$																
	ISO VG 220	⊘						$2,0 \leq n_2 \leq 140$						$n_2 > 140$				⊘
	ISO VG 320	⊘			$n_2 < 2,0$						$2,0 \leq n_2 \leq 140$							
	ISO VG 460	⊘			$2,0 \leq n_2 \leq 140$													
PAO synthetic oil (Polyalphaolefin)	ISO VG 150	$n_2 > 140$													⊘			
	ISO VG 220	⊘						$n_2 > 140$										
	ISO VG 320	⊘			$2,0 \leq n_2 \leq 140$						$n_2 > 140$							
	ISO VG 460	⊘			$2,0 \leq n_2 \leq 140$													
PAG synthetic oil (Poly Alkylene Glycol)	ISO VG 150	$n_2 > 140$													⊘			
	ISO VG 220	⊘						$n_2 > 140$										
	ISO VG 320	⊘			$2,0 \leq n_2 \leq 140$						$n_2 > 140$							
	ISO VG 460	⊘			$n_2 < 2,0$													

2) In the case of forced lubrication, the gear unit should only be operated when the oil temperature T_{oil} is higher than the temperature indicated in the table. During start-up of the lubrication unit, a short period of preheating may be necessary, to be carried out with the gear unit at standstill, before complete circulation of the oil and proper lubrication of the internal components is achieved.

- Admitted application field, optimal range.
- Admitted application field where higher absorption is expected due to higher viscosity; prefer gradual starts and partial load operation.
- Non-optimal application range; in this case it is recommended to use oils with viscosity grade at least 30 cSt referred to max oil temperature (T_{oil}) during the operation.
- Non-optimal application range; in this case it is necessary to foresee oil with Pour Point at least 10°C lower than the minimum temperature indicated by the field. Foresee a phase of rotation at no load (pre-heating) at least up to the attainment of a temperature T_{amb} equal or superior to the minimum indicated in the field of application admitted.

Application field not allowed. If necessary contact Rossi S.p.A.

$n_2 > 140$ Indicative output speed for selection of lubricant viscosity

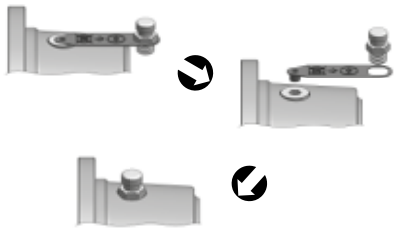

Carry out an overall check, making particularly sure that the gear reducer is filled with lubricant up to level and mounted according to the mounting position stated on name plate.



The filler plug and breather is supplied disassembled, positioned near its housing. Before commissioning, after positioning the gear reducer in the mounting position stated in the nameplate, replace the closed plug with the filler plug and breather (see fig.).

Oil filling



Pay attention to the correct position of the oil level plug (see ch. 6).

Where gear reducers is provided without lubricant, is necessary to fill it with appropriate oil before commissioning. In the same way, when parking brake is present, it is necessary filled as well with specific lubricant (see ch. 6)

For mounting positions with input side in vertical position, during the oil filling, it is very important to always open the plug located up to the level of air escape in order to reach the correct level.

When the output speed n_2 is lower than $0,3 \text{ min}^{-1}$ and the mounting position is horizontal, the gear reducer must be completely filled with oil.

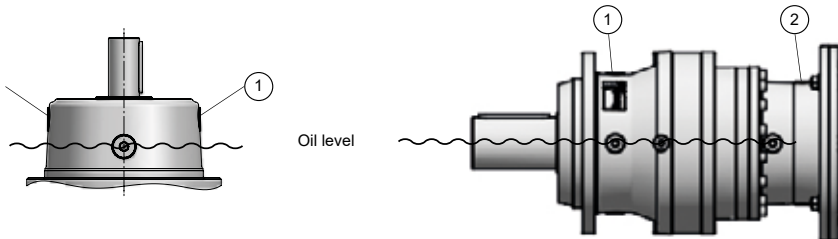

Oil filling:

- a. Open the plugs 1 and 2.
- b. Fill with oil by the plug 1 reaching the correct level
- c. Close the plugs 1 and 2.

Expansion tanks

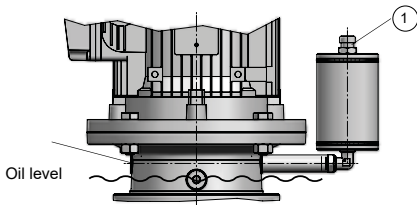

For some mounting positions, as foreseen in ch. 6 an expansion tank is needed in order to allow the correct oil level and the natural thermal expansion of lubricant.

It is very important that it must always be placed above the oil level.

For the oil filling consider the diagram below:

Oil filling:

- a. Open plugs 1 and 2.
- b. Fill with oil by the plug 1 up to reach the correct level
- c. Close plugs 1 and 2.

For sizes from 030A with mounting positions V3-V31-V32-V33, when ordered, the expansion tank kit does not include the piping arrangement. In these cases, please refer to the diagram below:

Mounting positions
V3-V31-V32-V33

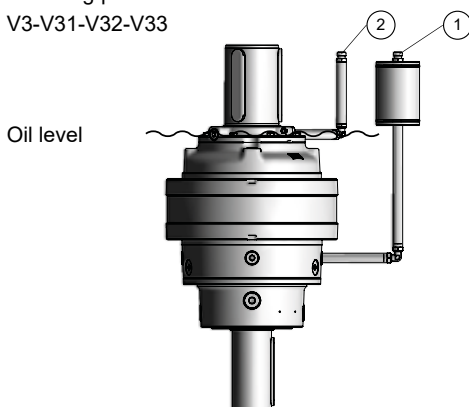

Oil filling:

- a. Open plugs 1 and 2.
- b. Fill with oil by the plug 1 up to reach the correct level
- c. Close plugs 1 and 2.

Plugs

For EP series plugs are magnetic. Size of plugs and breather plugs and values of tightening torque are shown below.

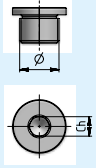
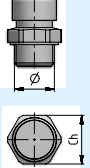
	Filler plugs				Breather plugs		
	Ø	Ch	Tightening torque [N m]		Ø	Ch	Tightening torque ¹⁾ [N m]
	G 1/8 "	5	8		G 1/4 "	17	12
	G 1/4 "	6	13		G 3/8 "	20	16
	G 3/8 "	8	20		G 1/2 "	24	23
	G 1/2 "	10	30		G 3/4 "	32	37
	G 3/4 "	12	45		G 1"	40	58
	G 1"	17	65		G 1" 1/4	50	105
	G 1" 1/4	22	100		G 1" 1/2	55	126
	G 1" 1/2	24	125				

1) Values valid with washer in alluminium.

For the first commissioning, before starting with a normal running cycle, it is advisable to run the gear reducer without load in order to verify if it correctly runs.

In this circumstance, cause of the elimination of potential residual air, an oil filling up to level could be necessary.

During this first run, it is important to check:

- noise level
- vibrations
- sealings

If you notice any malfunctions, please refer to ch. 8.13.

Brake release

To release the brake it is recommended the use of mineral-based hydraulic oil; synthetic oils may damage and cause malfunctions in the brake.

Connect the brake to the hydraulic circuit of machine through the brake release hole. Before first use it is necessary to bleed off.

Follow the instructions below:

- Slightly loosen the release fitting
- Release the brake at low pressure and wait for the complete bleeding off
- Tighten the release fitting

For further information refer to specific operating instructions manual.

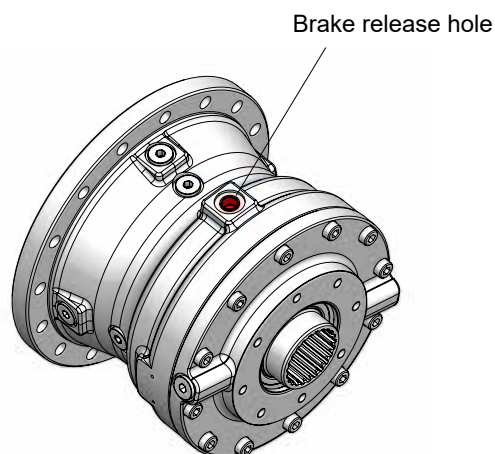

Integrated water cooling unit

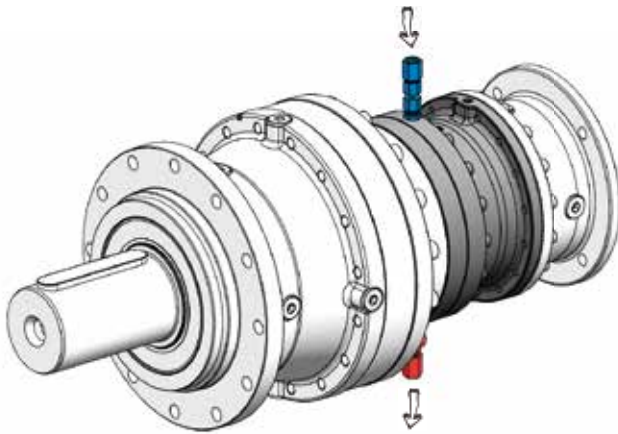

The gear reducers, according to the sizes, can be equipped with a water cooling unit.

Suggested cooling water specifications are:

- low hardness;
- max temperature 20 °C;
- minimum flow 3 dm³/min (l/min);
- pressure 0,2 ÷ 0,4 Mpa (2 ÷ 4 bar).

For the connection you may use standard fitting according to the female coupling sizes (see below).

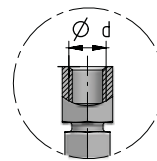

Be sure that all the connections are free of leakage.

1EL	2EL	3EL	4EL	2EB	3EB	4EB	d Ø	Code
001A ... 002A	001A ... 006A	001A ... 022A	001A ... 061A	001A ... 006A	001A ... 022A	001A ... 061A	G1/4"	RS1a
003A ... 006A	009A ... 022A	030A ... 061A	085A ... 180A	009A ... 015A, 022A	030A ... 043A	085A ... 125A	G1/4"	RS1b
009A ... 015A	030A ... 043A	085A ... 125A	250A ... 355A	018A ... 021A, 030A	061A ... 085A	180A ... 250A	G1/4"	RS1c

Integrated fan cooling unit

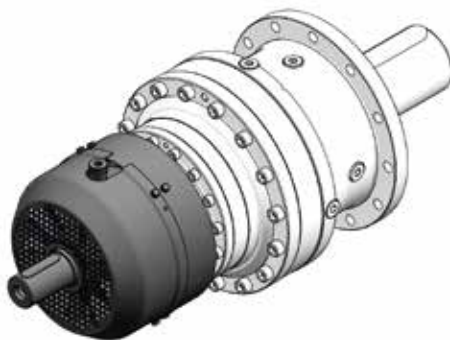

When a fan cooling unit is mounted, verify that there is sufficient space allowing for adequate circulation of cooling air also after fitting coupling protection (see below).

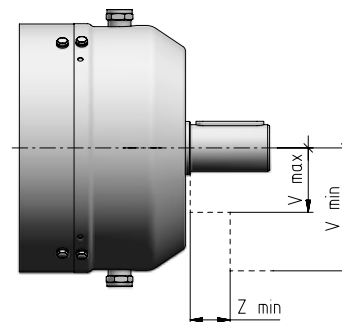

1EL	2EL	3EL	4EL	2EB	3EB	4EB	V _{max} Ø	V _{min} Ø	Z _{min}	Code
001A, 002A	001A ... 006A	001A ... 022A	001A ... 061A	001A ... 006A	001A ... 022A	001A ... 061A	70	195	27	V38×58
003A ... 006A	009A ... 022A	030A ... 061A	085A ... 180A	009A ... 015A, 022A	030A ... 043A	085A ... 125A	85	230	30	V48×82
009A ... 015A	030A ... 043A	085A ... 125A	250A ... 355A	018A, 021A, 030A	060A ... 085A	180A ... 250A	110	280	35	V60×105

Independent cooling units

Independent cooling unit with oil-air heat exchanger **UR O/A ...**

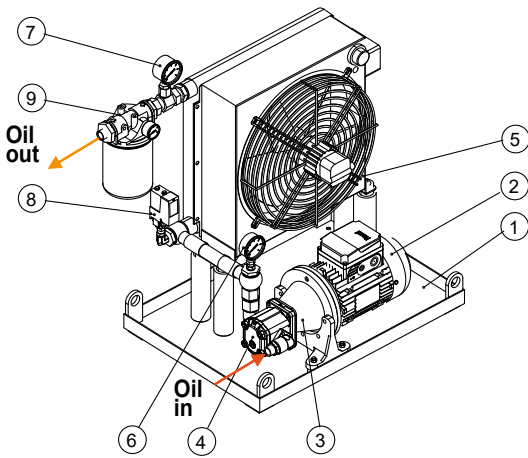

Pos.	Description
1	Basament
2	Electric motor
3	Coupling
4	Gear Pump
5	Heat Exchanger
6	Pressure Gauge
7	Thermometer
8	Pressure Switch
9	Output Filter

Independent cooling unit with oil-water heat exchanger **UR O/W ...**

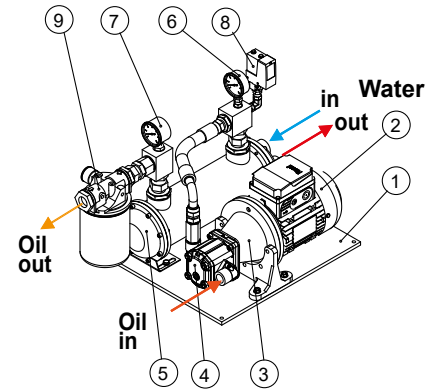

When natural cooling or integrated cooling units are not sufficient anymore (for thermal power verification see ch. 2), it is possible to install the independent cooling units described below.

Consisting of:

- **oil/air heat exchanger (O/A)** (with thermostat and adjustable control knob $0 \div 90 \text{ }^\circ\text{C}$) or **oil/water heat exchanger (O/W)**
- **motor pump**: screw or gear pump with fluoro rubber seals; 4 pole motor B3/B5 (three-phase $\Delta 230 \text{ Y} 400 \text{ V } 50 \text{ Hz}$); motor-pump connection with coupling
- **motor fan (O/A)** (three-phase supply $\Delta 230 \text{ Y} 400 \text{ V } 50 \text{ Hz}$ or single phase supply $230 \text{ V } 50, 60 \text{ Hz}$, see table)
 - **oil filter** (type Spin-On) with filtration degree $60\mu\text{m}$ (M60) and optical-electric blockage warning (BVR)
 - **analogic manometer** ($0 \div 16 \text{ bar}$) mounted between pump and exchanger
 - **analogic thermometer** ($0 \div 120 \text{ }^\circ\text{C}$) mounted at exchanger output
 - **low pressure switch** (with on-off switch) mounted between pump and exchanger
 - **supporting frame** with nameplate

On request, several accessories are at disposal (supplied separately, assembled by Customer) in order to satisfy all functionality and safety needs:

- **oil temperature probe Pt100**
- **2-threshold signalling device CT03** (necessary also the oil temperature probe Pt100) for the mounting on rail to DIN EN 50022
- **3-threshold signalling device CT10** (necessary also the oil temperature probe Pt100) for the mounting on rail to DIN EN 50022
- **bi-metal type thermostat**
- **flow gauge**

Connections realized by flexible pipes (type SAE 100 R1, maximum length 2 m) between gear reducer and cooling unit and the assembly of accessories and signalling devices are Buyer's responsibility.

When choosing the independent cooling unit, it is good to make sure that the flow rate (liters / minute) does not exceed 50% of the volume of lubricant present inside the gear reducer, in the specific mounting position.

Excellent performance reachable with air temperature at max $25 \text{ }^\circ\text{C}$ for UR O/A and water temperature at max $20 \text{ }^\circ\text{C}$ for UR O/W.

Be sure that the capacity of selected cooling unit is lower or equal to the lubricant quantity present inside the gear reducer.

Excellent performance reachable with air temperature at max $25 \text{ }^\circ\text{C}$ for UR O/A and water temperature at max $20 \text{ }^\circ\text{C}$ for UR O/W.

Operational features - UR O/A ... - EP

Designation	P_s [kW]	Air Oil Heat Exchanger	Oil motor pump		Air Oil heat Exchanger features						Oil filter type		
			Motor Power [kW]	Capacity [dm³/min]	Electric fan side		Oil side		Oil vol. [dm³]	Size and filtering	Optical pressure gauge		
					Power and motor type		Oil suction fem. conn.	Oil delivery fem. conn.					
					kW [50Hz / 230V-400V]	kW [60 Hz / 265V-460V]	n° and size	n° and size					
URO/A 5 - EP	5	AP 300 E	0,75	6	0,12 / 0,20	0,15 / 0,23	1× G 3/4"	1× G 3/4"	2	MPS 050 M60	BVR	60	
URO/A 7 - EP	7	AP 300 E	0,75	9	0,12 / 0,20	0,15 / 0,23	1× G 3/4"	1× G 3/4"	2	MPS 050 M60	BVR	64	
URO/A 9 - EP	9	AP 300/2 E	0,75	11	0,12 / 0,20	0,15 / 0,23	1× G 3/4"	1× G 3/4"	4	MPS 050 M60	BVR	70	
URO/A 13 - EP	13	AP 430 E	1,1	16	0,11 / 0,21	0,11 / 0,20	1× G 3/4"	1× G 3/4"	4	MPS 100 M60	BVR	75	
URO/A 20 - EP	20	AP 430/2 E	1,1	20	0,11 / 0,18	0,15 / 0,26	1× G 3/4"	1× G 3/4"	6	MPS 100 M60	BVR	115	
URO/A 28 - EP	28	AP 580 EB	1,5	46	0,11 / 0,18	0,15 / 0,26	2× G 3/4"	2× G 3/4"	12	MPS 100 M60	BVR	125	
URO/A 40 - EP	40	AP 680 EB	1,5	46	0,70	1,1	2× G 1"	2× G 1"	15	MPS 150 M60	BVR	140	
URO/A 48 - EP	48	AP 730 EB	2,2	56	0,70	1,1	2× G 1"	2× G 1"	15	MPS 150 M60	BVR	150	

1) P_s performance valid for altitude from 0 to 1 000 m a.s.l. Reduce performance value P_s x 0,85 (from 1 000 to 2 500 m a.s.l.) or P_s x 0,71 (from 2 500 to 5 000 m a.s.l.)

Operational features - UR O/W ... - EP

Designation	P_s [kW]	Oil Water Heat Exchanger	Oil motor pump		Water Oil Exchanger features						Oil filter type		
			Motor Power [kW]	Capacity [dm³/min]	Water side		Oil side		Oil vol. [dm³]	Size and filtering	Optical pressure gauge		
					Capacity [dm³/min]	Suction fem. conn.	Delivery fem. conn.	Oil suction fem. conn.				Oil delivery fem. conn.	
					n° and size	n° and size	n° and size	n° and size					
URO/W 4 - EP	4	T80 CB2	0,37	6	≥ 30 ≤ 60	1× Ø17 - 1/2"	1× Ø17 - G1/2"	1× G 3/4"	1× G 3/4"	1,0	MPS 050 M60	BVR	14
URO/W 6 - EP	6	T80 CB3	0,37	6	≥ 30 ≤ 80	1× Ø17 - 1/2"	1× Ø17 - G1/2"	1× G 3/4"	1× G 3/4"	1,6	MPS 050 M60	BVR	16
URO/W 9 - EP	9	T80 CB3	0,75	13	≥ 30 ≤ 80	1× Ø17 - 1/2"	1× Ø17 - G1/2"	1× G 3/4"	1× G 3/4"	1,6	MPS 050 M60	BVR	20
URO/W 13 - EP	13	MS 134P1	1,1	20	≥ 60 ≤ 110	1× G 1"	1× G 1"	1× G 3/4"	1× G 3/4"	2,8	MPS 100 M60	BVR	30
URO/W 20 - EP	20	MS 134P1	1,1	30	≥ 60 ≤ 110	1× G 1"	1× G 1"	2× G 3/4"	2× G 3/4"	2,8	MPS 100 M60	BVR	32
URO/W 32 - EP	32	MS 134P2	1,5	40	≥ 80 ≤ 110	1× G 1"	1× G 1"	2× G 1"	2× G 1"	4,6	MPS 150 M60	BVR	60
URO/W 48 - EP	48	MS 134P4	1,5	60	≥ 100 ≤ 120	1× G 1"	1× G 1"	2× G 1"	2× G 1"	6,8	MPS 150 M60	BVR	75

Starting mode and required accessories

Ref.	T_{amb} °C	Required accessories	Required oil type	Description and remarks
A1	0 ÷ 25	Pt100 + CT10	Polyalphaolefine based synthetic oil or Mineral oil	Gear reducer starting and subsequent motor-pump starting with warm oil. The motor-pump is managed by the three-threshold oil temperature control system (Pt100 + CT10). Set the three-threshold device CT10 with: • operating temperature 60 °C (starting of motor-pump); • restoring temperature 40 °C; • warning temperature 90° C.
A2	> 25	–	Polyalphaolefine based synthetic oil	Simultaneous starting of gear reducer and motor-pump

Additional description when ordering by **designation**:

independent oil-air cooling unit UR O/A ... - EP or independent oil-water cooling unit UR O/W ... - EP.

For more details about reference starting mode A1 / A2, see specific literature.

For dimensions, accessories and further technical details, see specific literature.

Design advice for independent cooling units

For the design of the cooling system, see the following instructions and sample diagrams.

It is recommended for suction to be in the lowest point and that suction and delivery points are adequately distant from each other. For the design of independent units, see chapter 7.8.

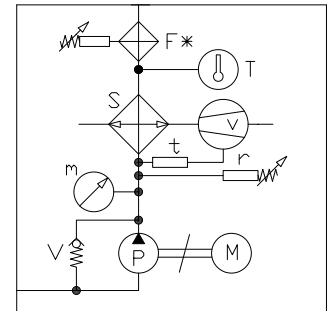
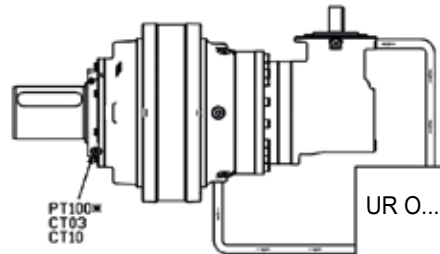
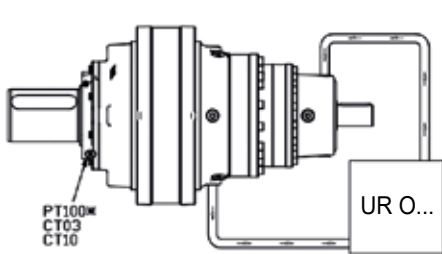

UR O ...

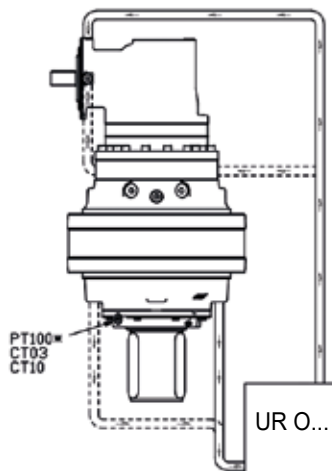
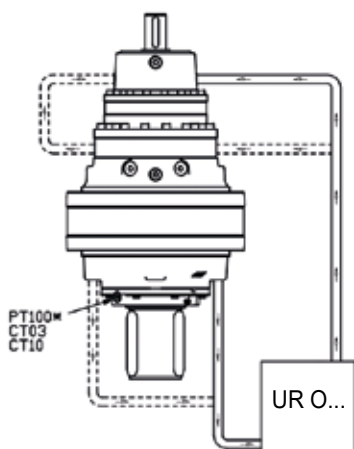

Legend:

- Pt 100** oil temperature probe (supplied separately)
- F** filter with electric clogging signaller (with UR O/W... it is supplied separately)
- m** manometer 0 ÷ 16 bar
- M** motor pump
- P** pump
- CT 03*, CT10*** signalling device (supplied separately)
- S** oil/air or oil/water heat exchanger
- v** motor fan (UR O/A ...)
- t** fan thermostat 0 ÷ 90 °C (UR O/A...)
- T** thermometer 0 ÷ 120 °C
- V** safety valve 6 bar (screw pump)
- r** low pressure switch

* On request.

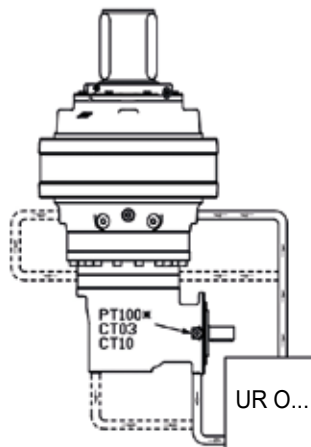
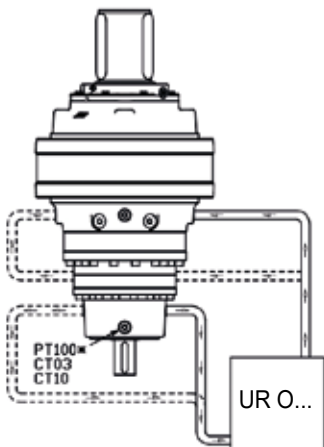

Oil flow capacity of holes

Plugs size	d [mm]	q _s (max) [l/min]	q _d (max) [l/min]
G 1/4"	7	3	5
G 3/8"	10	6	10
G 1/2"	12	9	15
G 3/4"	16	16	27
G 1"	22	30	51
G 1 1/4"	30	56	95

Stated values are valid with a kinematic oil viscosity of about 60 Cst.

For exact oil levels, plug positions and size, expansions tanks, see ch. 6.

It is very important to design the hydraulic circuit according to the following indications:

$$q_s \leq Q_R$$

q_s max delivery in suction for 1 hole.

q_d max delivery sending for 1 hole.

Q_R is the gear reducer oil quantity at correct level, see ch. 6, cat. EP series.

d internal diameter of fitting and pipes.

Where the use of only one hole is not enough to dispose all the oil flow, 2 or more holes can be connected at the main pipelines (suction and delivery).

Obviously, being a closed circuit, the total oil flow in suction and delivery must be equivalent.

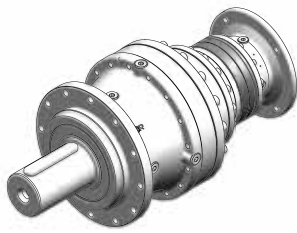

The presence on gear reducer of backstop device is stated by a specific label indicating the free rotation. This system allows the rotation in one specific direction preventing the counter-rotation when the drive is switched off. The exact direction of free rotation is stated on a specific label on the gear reducer.



Attention! Do not start motor in the false direction! Danger!

Maintenance

At machine rest, verify at regular intervals (more or less frequently according to environment and use):

- a) all external surfaces are clean and air passages to the gear reducer are free, in order that cooling remains fully effective. An accumulation of dust impedes efficient heat dispensal from the gear reducer housing and must be removed;
- b) oil level and deterioration degree (check with cold gear reducer at rest);
- c) correct fastening screws tightening.

During operation, check periodically:

- noise level;
- vibrations;
- sealings;
- etc.

Attention! After a running period, gear reducer is subject to a light internal overpressure which may cause burning liquid discharge. Therefore, before loosening whichever plug (filler plug included) wait until gear reducer has become cold and open it carefully; if not possible, take the necessary protection measures against burning due to warm oil contact. In all cases, always proceed with great care.

Maximum oil temperatures indicated on lubrication table do not represent a hindrance to the gear reducer regular running.

Consider the lubrication interval stated in the table for all re-lubrication operations.

Use only lubricants of the same type stated on lubrication nameplate.

Oil temperature [°C]	Oil-change interval [h]	
	synthetic oil	mineral oil
≤ 65	12 500	5 600
65 ÷ 80	10 000	2 800
80 ÷ 95	6 300	1 400

Oil-change intervals assume pollution-free environment. When heavy overloads are present, halve the values.

Independently from running times, change the oil:

every 2 ÷ 4 years, for synthetic oil;

every 1 ÷ 2 years, for mineral oil;

During oil change operation, after unscrewing also the filler plug in order to facilitate oil draining (for plug position see ch. 6):

- wash the inside part of gear reducer housing using the same oil type suitable for the running (stated on lubrication nameplate); the oil used for this wash can be applied for further washings after proper filtering by 25 µm of filtration standard;
- clean, using a compressed air stream, all magnetic plugs, taking care to assemble them again in their original position;
- fill in the gear reducer with new oil up to level, using only oil of the same type and viscosity as per lubrication nameplate.

1) The lubricant quantities stated in ch. 6 are approximate and indicative for provisioning. The exact oil quantity the gear reducer is to be filled with is definitely given by the level. When output speed n_2 is lower than $0,3 \text{ min}^{-1}$, for all mounting positions please refer to the approximate oil quantities stated for V1 position.

Replace the seal rings in case of dismantling or of periodical check; in this case, the new ring must be positioned so that it does not work on the same sliding race of previous ring.

Seal rings

Duration depends on several factors such as dragging speed, temperature, ambient conditions, etc.; as a rough guide it can vary from 1 600 ÷ 12 500 h.

For sizes above 030A (except 031A, 043A), refill output seals with grease every 3 000 operating hours or at least every 6 months.

Re-greasing procedure for slewing output bearings

In case of gear reducers with slewing outputs (output design R-S-H), independently from mounting position, the output bearing presents an independent lubrication with grease.

The re-greasing of bearing must be realized with the same oil change intervals.

It is advisable to re-grease the bearings and the seals with the same grease the gear reducer was supplied with. As alternative, you can use greases with the same specifications.

ATTENTION: the re-greasing procedure may cause a grease passage from bearing lubrication area to oil lubrication area. This does not involve any malfunctioning of gear reducer. It is anyway recommended to re-grease before gear reducer oil change, so that the eventual grease into the oil lubrication area is expelled.

For grease quantities consider the following table data.

Size	R		S		H	
	output design	gHease quantity g	output design	gHease quantity g	output design	gHease quantity g
007A	H30b	50	S30b	50	H30b	50
015A	H30c	100	S30c	100	H30c	70
021A	H30d	120	S30d	120	H30d	120
030A	H30e	150	S30e	150	H30e	150
042A	H30f	170	S30f	170	H30f	170
060A	H30g	200	S30g	200	H30g	200
085A	H30h	220	S30h	220	H30h	220
125A	H30i	250	S30i	250	H30i	250
180A	H30j	300	S30j	300	H30j	300
250A	H30k	350	S30k	350	H30k	350

001A ... 021A

Mounting positions¹⁾ (Output mounting ... F..., ... A...)

B5



V1*



V3**



* Based on the motor size, the expansion tank is required (see page 6.23).

** Based on the output design, the expansion tank is required (see page 6.27).

● Reference hole for the identification of the mounting position.

1) The drawings show the terminal box in position 0. For different positions of terminal box see page 6.22.

Mounting positions¹⁾ (Output mounting ... P...)

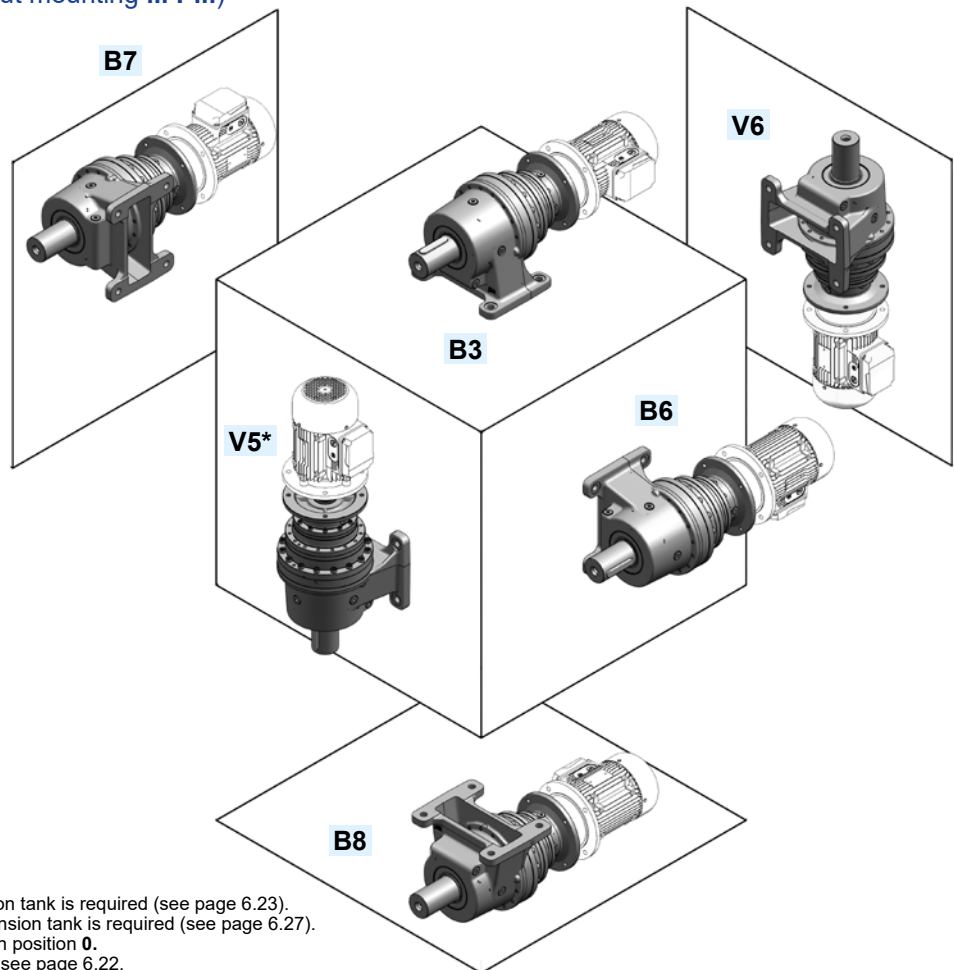

* Based on the motor size, the expansion tank is required (see page 6.23).

** Based on the output design, the expansion tank is required (see page 6.27).

1) The drawings show the terminal box in position 0.

For different positions of terminal box see page 6.22.

Oil quantities²⁾ [l]

Q _R	1EL										2EL										3EL										4EL									
	001A	002A	003A	004A	006A	009A	012A	015A	018A	021A	001A	002A	003A	004A	006A	009A	012A	015A	018A	021A	001A	002A	003A	004A	006A	009A	012A	015A	018A	021A	001A	002A	003A	004A	006A	009A	012A	015A	018A	021A
B3 ... B8	0,7	0,7	1,2	1,3	1,3	2	1,9	1,9	3	3,4	0,8	0,8	1,3	1,4	1,4	2,7	2,6	2,6	3,2	3,2	1	1	1,4	1,5	1,4	2,5	2,6	2,6	3,3	3,3	1,1	1,1	1,5	1,6	1,5	2,6	2,6	2,6	3,2	3,2
V1, V5	0,8	0,8	1,5	1,6	1,4	2,5	2	2,1	3,9	4	1,1	1,2	2	2,2	2,1	3,9	3,9	3,9	5,1	5	1,5	1,5	2,3	2,5	2,3	4,5	4,4	4,4	5,8	5,8	1,8	1,8	2,6	2,8	2,6	4,8	4,8	4,8	6	6
V3, V6	1	1	1,9	2,1	2	2,9	2,8	2,9	4,3	5,2	1,3	1,3	2,1	2,3	2,3	4,1	4,3	4,3	4,8	4,7	1,6	1,7	2,2	2,4	2,2	3,9	4,1	4,1	4,8	4,8	1,8	1,9	2,5	2,7	2,5	4	4,3	4,3	4,8	4,8

2) Stated oil quantities are approximate for provisioning. The exact quantity gear reducer is to be filled with is definitely given by the level.

001A ... 021A

Mounting positions¹⁾ (Output mounting ... F..., ... A...)



* Based on the motor size, the expansion tank is required (see page 6.23).

** Based on the output design, the expansion tank is required (see page 6.27).

● Reference hole for the identification of the mounting position.

1) The drawings show the terminal box in position 0. For different positions of terminal box see page 6.22.

Oil quantities²⁾ [l]

Q _R	2EB										3EB						4EB													
	001A	002A	003A	004A	006A	009A	012A	015A	018A	021A	001A	002A	003A	004A	006A	009A	012A	015A	018A	021A	001A	002A	003A	004A	006A	009A	012A	015A	018A	021A
V3 ... V33	2,7	2,8	4,4	4,5	4,4	8,2	8,3	8,3	14,3	14,3	3	3,1	3,7	3,8	3,6	6,1	6,3	6,3	6,8	6,8	3,3	3,3	3,9	4,1	3,9	5,4	5,6	5,6	6,2	6,2
B5, B53	1,5	1,5	2,5	2,5	2,5	4,7	4,6	4,6	8	8	1,7	1,7	2,1	2,2	2,1	3,7	3,6	3,6	4,2	4,3	1,8	1,8	2,2	2,3	2,2	3,3	3,3	3,3	4	4
B51	2,6	2,6	4,2	4,3	4,2	8	7,8	7,8	13,3	13,3	2,9	2,9	3,7	3,9	3,7	6,6	6,5	6,5	7,7	7,7	3,2	3,2	4	4,2	4	6,2	6,1	6,1	7,4	7,4
B52	1,8	1,9	3	3	3	5,6	5,6	5,6	9,8	9,8	2	2	2,4	2,5	2,4	4,2	4,1	4,1	4,7	4,8	2,1	2,1	2,5	2,6	2,5	3,6	3,6	3,6	4,3	4,3
V1 ... V13	1,9	1,9	3	3,1	3	5,7	5,5	5,5	9,4	9,4	2,2	2,2	3	3,2	3	5,4	5,4	5,4	6,5	6,6	2,5	2,5	3,3	3,5	3,3	5,5	5,4	5,4	6,7	6,7

2) Stated oil quantities are approximate for provisioning. The exact quantity gear reducer is to be filled with is definitely given by the level.

001A ... 021A

Mounting positions¹⁾ (Output mounting ... P...)

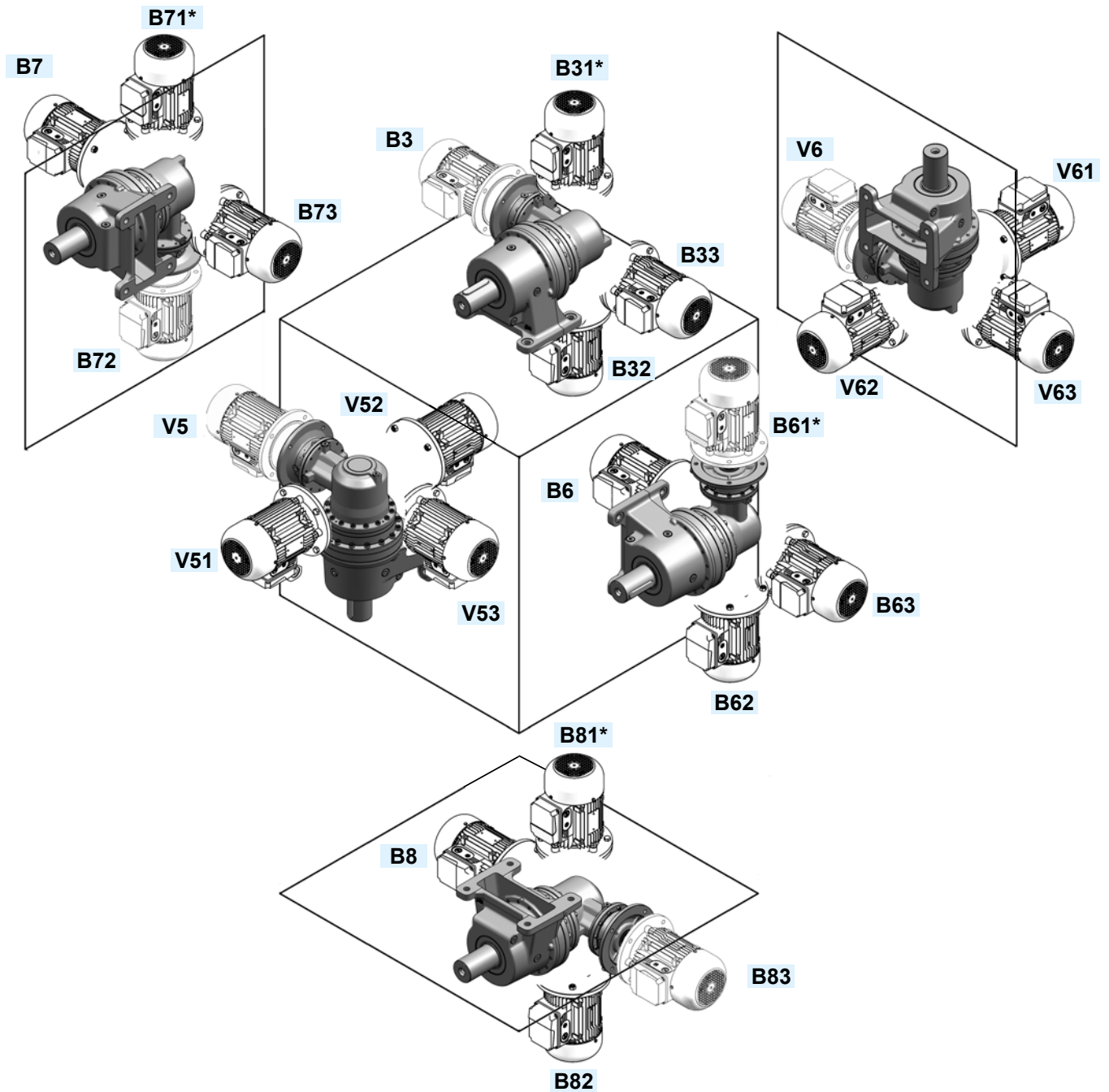

* Based on the motor size, the expansion tank is required (see page 6.23).

1) The drawings show the terminal box in position 0. For different positions of terminal box see page 6.22.

Oil quantities²⁾ [l]

Q _R	2EB										3EB										4EB									
	001A	002A	003A	004A	006A	009A	012A	015A	018A	021A	001A	002A	003A	004A	006A	009A	012A	015A	018A	021A	001A	002A	003A	004A	006A	009A	012A	015A	018A	021A
B3 ... B8	1,5	1,5	2,5	2,5	2,5	4,7	4,6	4,6	8	8	1,7	1,7	2,1	2,2	2,1	3,7	3,6	3,6	4,2	4,3	1,8	1,8	2,2	2,3	2,2	3,3	3,3	3,3	4	4
B33 ... B83	1,5	1,5	2,5	2,5	2,5	4,7	4,6	4,6	8	8	1,7	1,7	2,1	2,2	2,1	3,7	3,6	3,6	4,2	4,3	1,8	1,8	2,2	2,3	2,2	3,3	3,3	3,3	4	4
B31 ... B81	2,6	2,6	4,2	4,3	4,2	8	7,8	7,8	13,3	13,3	2,9	2,9	3,7	3,9	3,7	6,6	6,5	6,5	7,7	7,7	3,2	3,2	4	4,2	4	6,2	6,1	6,1	7,4	7,4
B32 ... B82	1,8	1,9	3	3	3	5,6	5,6	5,6	9,8	9,8	2	2	2,4	2,5	2,4	4,2	4,1	4,1	4,7	4,8	2,1	2,1	2,5	2,6	2,5	3,6	3,6	3,6	4,3	4,3
V5 ... V53	1,9	1,9	3	3,1	3	5,7	5,5	5,5	9,4	9,4	2,2	2,2	3	3,2	3	5,4	5,4	5,4	6,5	6,6	2,5	2,5	3,3	3,5	3,3	5,5	5,4	5,4	6,7	6,7
V6 ... V63	2,7	2,8	4,4	4,5	4,4	8,2	8,3	8,3	14,3	14,3	3	3,1	3,7	3,8	3,6	6,1	6,3	6,3	6,8	6,8	3,3	3,3	3,9	4,1	3,9	5,4	5,6	5,6	6,2	6,2

2) Stated oil quantities are approximate for provisioning. The exact quantity gear reducer is to be filled with is definitely given by the level.

001A ... 021A

Mounting positions (Output mounting ... F..., ... A...)

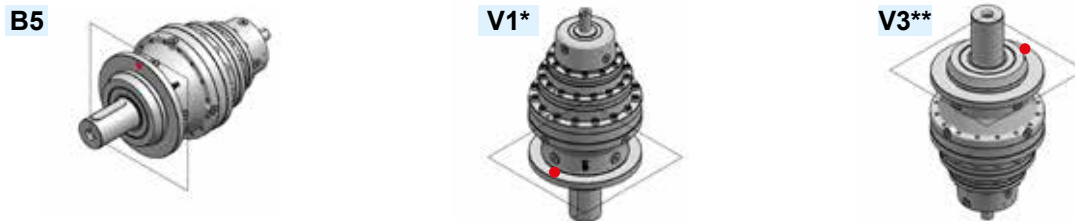

* Based on the gear reducer size and input type, the expansion tank is required (see page 6.23).

** Based on the output type, the expansion tank is required (see page 6.27).

● Reference hole for the identification of the mounting position.

Mounting positions (Design ... P...)

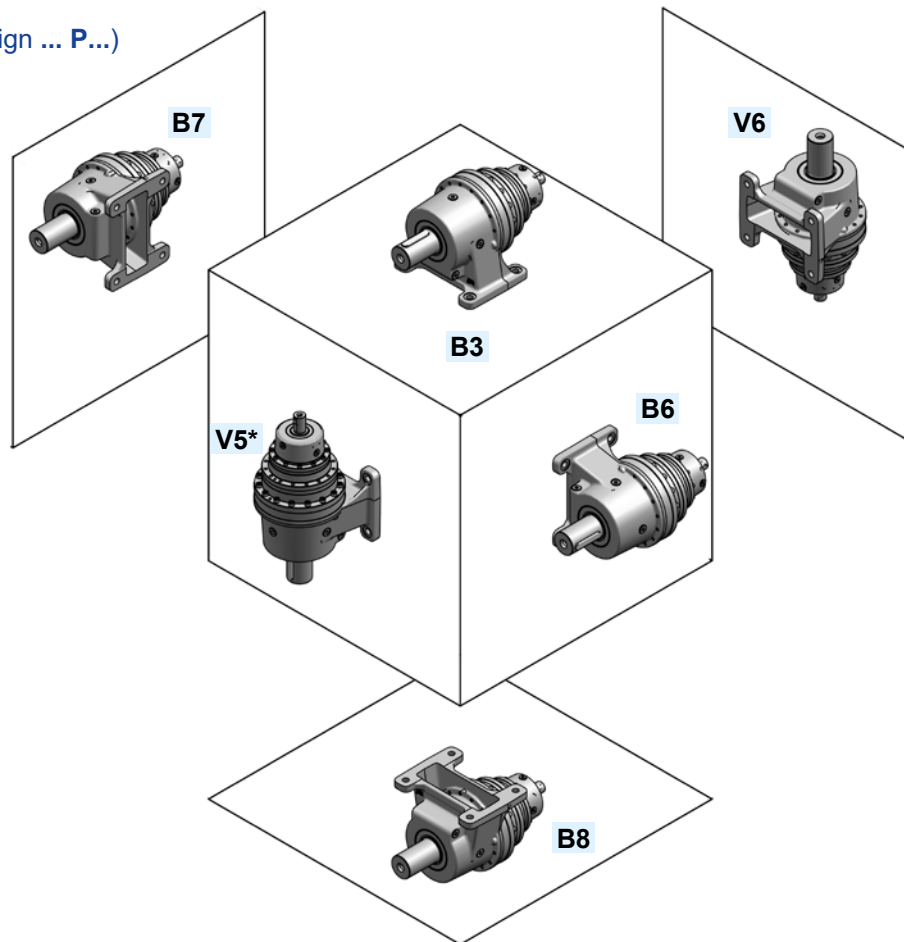

* Based on the gear reducer size and input type, the expansion tank is required (see page 6.23).

Oil quantities¹⁾ [l]

Q _R	1EL										2EL										3EL										4EL									
	001A	002A	003A	004A	006A	009A	012A	015A	018A	021A	001A	002A	003A	004A	006A	009A	012A	015A	018A	021A	001A	002A	003A	004A	006A	009A	012A	015A	018A	021A	001A	002A	003A	004A	006A	009A	012A	015A	018A	021A
B3 ... B8	0,7	0,7	1,4	1,4	1,2	2,2	2	2	3,1	3	0,8	0,8	1,3	1,3	1,2	2,5	2,5	2,5	3	3	1	1	1,4	1,5	1,4	2,5	2,5	2,5	3,1	3,1	1,2	1,2	1,6	1,7	1,6	2,6	2,6	2,6	3,3	3,3
V1, V5	1,4	1,4	2,7	2,7	2,5	4,4	3,9	4	6,2	6,1	1,7	1,7	2,5	2,7	2,5	5	4,9	4,9	6,1	6	2	2	2,8	3	2,8	5	4,9	4,9	6,2	6,2	2,3	2,3	3,2	3,3	3,2	5,3	5,3	5,3	6,5	6,5
V3, V6	1	1,1	2,2	2,1	1,9	3,2	2,9	3	4,5	4,4	1,3	1,4	2	2,1	1,9	3,8	3,9	3,9	4,4	4,3	1,6	1,7	2,3	2,4	2,3	3,8	3,9	3,9	4,5	4,5	2	2	2,6	2,8	2,6	4,1	4,3	4,3	4,8	4,8

1) Stated oil quantities are approximate for provisioning. The exact quantity the gear reducer is to be filled with is definitely given by the level.

001A ... 021A

Mounting positions (Output mounting ... F..., ... A...)

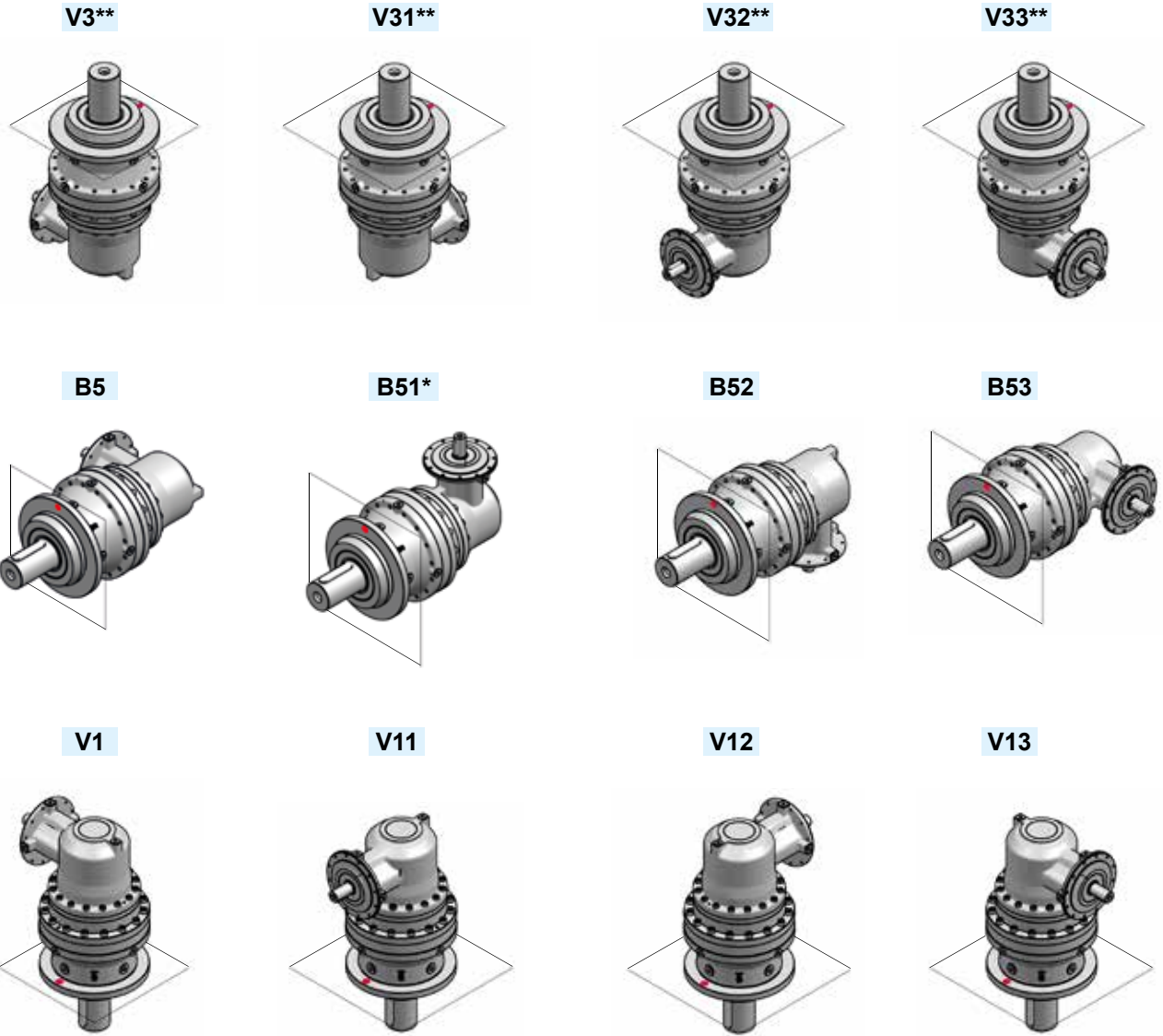

* Based on the gear reducer size and input type, the expansion tank is required (see page 6.23).

** Based on the output design, the expansion tank is required (see page 6.27).

● Reference hole for the identification of the mounting position.

Oil quantities¹⁾ [l]

Q _R	2EB										3EB						4EB													
	001A	002A	003A	004A	006A	009A	012A	015A	018A	021A	001A	002A	003A	004A	006A	009A	012A	015A	018A	021A	001A	002A	003A	004A	006A	009A	012A	015A	018A	021A
V3 ... V33	2	2,1	3,4	3,5	3,3	6,4	6,4	6,4	10,7	10,7	2,4	2,4	3	3,2	3	5,1	5,3	5,3	5,8	5,8	2,7	2,8	3,4	3,5	3,3	4,8	5	5	5,6	5,6
B5, B53	1,2	1,2	2	2	2	3,8	3,7	3,7	6,2	6,2	1,4	1,4	1,8	1,9	1,8	3,2	3,1	3,1	3,7	3,7	1,5	1,5	2	2	1,9	3	3	3	3,6	3,6
B51	2,4	2,4	3,9	4,1	3,9	7,6	7,4	7,4	12,4	12,4	2,7	2,7	3,6	3,7	3,6	6,3	6,3	6,3	7,4	7,4	3,1	3,1	3,9	4,1	3,9	6	6	6	7,3	7,3
B52	1,2	1,2	2	2	2	3,8	3,7	3,7	6,2	6,2	1,4	1,4	1,8	1,9	1,8	3,2	3,1	3,1	3,7	3,7	1,5	1,5	2	2	1,9	3	3	3	3,6	3,6
V1 ... V13	1,5	1,5	2,5	2,6	2,5	4,8	4,6	4,6	7,6	7,6	1,9	1,9	2,7	2,9	2,7	4,9	4,9	4,9	6	6	2,2	2,2	3	3,2	3	5,1	5,1	5,1	6,4	6,4

1) Stated oil quantities are approximate for provisioning. The exact quantity gear reducer is to be filled with is definitely given by the level.

001A ... 021A

Mounting positions (Output mounting ... P...)

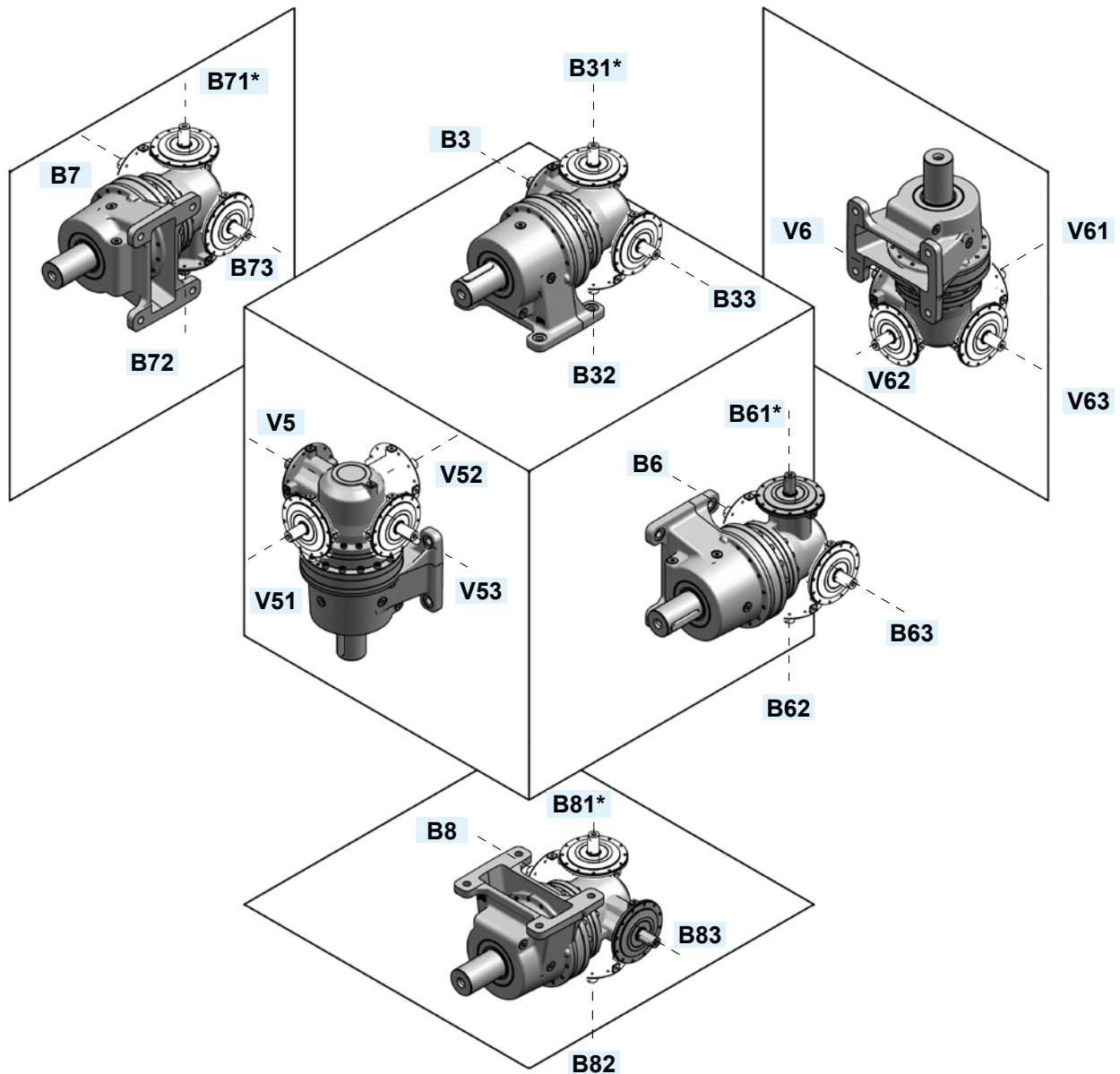

* Based on the gear reducer size and input type, the expansion tank is required (see page 6.23).

Oil quantities¹⁾ [l]

Q _R	2EB										3EB						4EB													
	001A	002A	003A	004A	006A	009A	012A	015A	018A	021A	001A	002A	003A	004A	006A	009A	012A	015A	018A	021A	001A	002A	003A	004A	006A	009A	012A	015A	018A	021A
B3 ... B8	1,2	1,2	2	2	2	3,8	3,7	3,7	6,2	6,2	1,4	1,4	1,8	1,9	1,8	3,2	3,1	3,1	3,7	3,7	1,5	1,5	2	2	1,9	3	3	3	3,6	3,6
B33 ... B83	1,2	1,2	2	2	2	3,8	3,7	3,7	6,2	6,2	1,4	1,4	1,8	1,9	1,8	3,2	3,1	3,1	3,7	3,7	1,5	1,5	2	2	1,9	3	3	3	3,6	3,6
B31 ... B81	2,4	2,4	3,9	4,1	3,9	7,6	7,4	7,4	12,4	12,4	2,7	2,7	3,6	3,7	3,6	6,3	6,3	6,3	7,4	7,4	3,1	3,1	3,9	4,1	3,9	6	6	6	7,3	7,3
B32 ... B82	1,2	1,2	2	2	2	3,8	3,7	3,7	6,2	6,2	1,4	1,4	1,8	1,9	1,8	3,2	3,1	3,1	3,7	3,7	1,5	1,5	2	2	1,9	3	3	3	3,6	3,6
V5 ... V53	1,5	1,5	2,5	2,6	2,5	4,8	4,6	4,6	7,6	7,6	1,9	1,9	2,7	2,9	2,7	4,9	4,9	4,9	6	6	2,2	2,2	3	3,2	3	5,1	5,1	5,1	6,4	6,4
V6 ... V63	2	2	3,4	3,5	3,3	6,4	6,4	6,4	10,7	10,7	2,4	2,4	3	3,2	3	5,1	5,3	5,3	5,8	5,8	2,7	2,8	3,4	3,5	3,3	4,8	5	5	5,6	5,6

1) Stated oil quantities are approximate for provisioning. The exact quantity gear reducer is to be filled with is definitely given by the level.

022A ... 710A

Mounting positions¹⁾ (Output mounting ... F..., ... A...)



* Based on the motor size, the expansion tank is required (see page 6.23).

** Based on the output design, the expansion tank is required (see page 6.27).

● Reference hole for the identification of the mounting position.

1) The drawings show the terminal box in position 0. For different positions of terminal box see page 6.22.

Oil quantities²⁾ [l]

Q _R	1EL					2EL							
	022A	030A	031A	042A	043A	022A	030A	031A	042A	043A	060A 061A	085A	125A
B5	2,9	3,2	4,5	4,4	5,6	2,7	4,4	5,9	5,3	6,7	6,7	7,7	14
V1	3,6	5,2	8,1	7,5	10,2	3,9	6,2	9,2	8	10,8	10,6	14,1	24
V3	3,3	6,5	5	8,8	6	2,9	8,9	7,8	10,7	8,3	13,5	15,4	27

Q _R	3EL											4EL												
	022A	030A	031A	042A	043A	060A 061A	085A	125A	180A	250A	355A	022A	030A	031A	042A	043A	060A 061A	085A	125A	180A	250A	355A	500A	710A
B5	3,1	3,6	5,1	4,9	6,3	6,3	7,9	15	22	32	45	3,1	3,6	5,1	5	6,4	6,2	8,1	15	22	33	46	59	89
V1	5,5	6	9	8,7	11,5	11,4	14,5	27	40	60	86	5,7	6,8	9,8	9,5	12,3	11,9	15,5	29	43	63	89	114	174
V3	3,8	7,1	6,1	9,8	7,5	12,5	15,8	29	43	63	89	3,8	7,3	6,2	10	7,6	12,4	16,2	30	44	65	91	117	177

2) Stated oil quantities are approximate for provisioning. The exact quantity gear reducer is to be filled with is definitely given by the level.

022A ... 710A

Mounting positions¹⁾ (Output mounting ... F..., ... A...)



* Based on the output design, the expansion tank is required (see page 6.27).

● Reference hole for the identification of the mounting position.

1) The drawings show the terminal box in position 0. For different positions of terminal box see page 6.22.

Oil quantities²⁾ [l]

Q _R	2EB								3EB								4EB																	
	022A	030A	031A	042A	043A	060A	061A	085A	125A	022A	030A	031A	042A	043A	060A	061A	085A	125A	180A	250A	355A	022A	030A	031A	042A	043A	060A	061A	085A	125A	180A	250A	355A	500A
V3 ... V33	11,2	12,5	12,4	18,8	15,7	20	33,5	45	6,5	11	10	14,5	11,9	20,5	20,6	42	56	84	106	4,9	10,3	8,1	11,9	9,6	14,6	23,6	36	52	68	101	125	196		
B5, B53	6,8	6,3	8,2	9,4	10,4	10	16,8	23	4,4	5,5	7	7,3	8,5	10,2	10,3	21	28	42	53	3,6	5,1	6,1	6	7,4	7,3	11,8	18	26	34	51	63	98		
B51	12,5	9,9	16,5	18,8	20,8	20	33,5	44	8,1	9,9	12,9	13,2	15,9	19,1	19,2	38	52	82	104	6,8	9,8	11,7	11,5	14,3	14,2	22,9	32	50	66	98	122	194		
B52	7,6	8	8,2	9,4	10,4	10	16,8	27	4,9	6,3	7,8	8,2	9,3	11,1	11,2	21	44	46	57	4	5,4	6,4	6,3	7,7	7,6	12,2	18	26	34	51	63	102		
V1 ... V13	10,1	7,8	10,6	13	15	14,2	20,5	31	6,9	7,5	10,5	10,8	13,5	14,8	16,7	34	52	70	92	6,1	8,5	10,4	10,2	13	12,9	20,3	32	46	64	93	118	182		

2) Stated oil quantities are approximate for provisioning. The exact quantity gear reducer is to be filled with is definitely given by the level.

022A ... 710A

Mounting positions (Output mounting ... F..., ... A...)

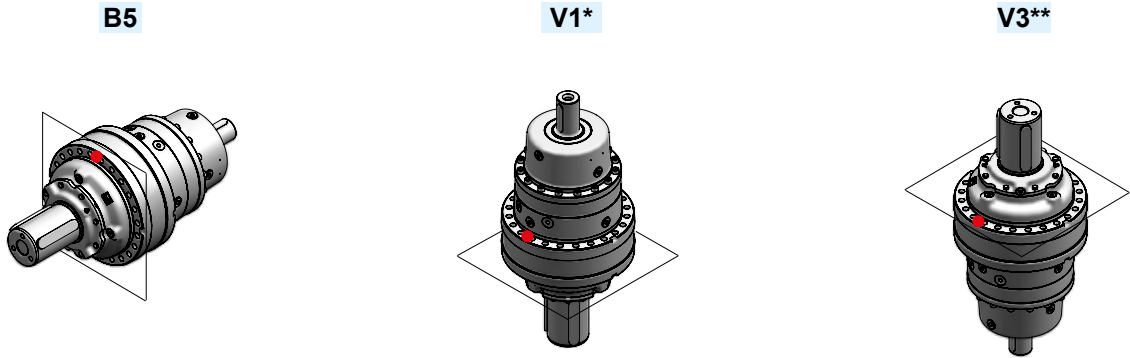

- ** Based on the output design, the expansion tank is required (see page 6.27)
- * Based on the gear reducer size and input type, the expansion tank is required (see page 6.23).
- Reference hole for the identification of the mounting position.

Oil quantities¹⁾ [l]

Q _R	1EL				2EL												
	030A	031A	042A	043A	022A	030A	031A	042A	043A	060A 061A	085A	125A	180A	250A	355A	500A	710A
B5	2,8	4,3	4	5,4	2,5	3,9	5,4	4,8	6,2	6,4	7,2	13	21	30	43	56	81
V1	5,6	8,6	7,9	10,7	4,9	7,8	10,8	9,6	12,4	12,7	14,5	26	42	60	86	112	162
V3	5,6	4,6	7,9	5,6	2,5	7,8	6,8	9,6	7,3	12,7	14,5	26	42	60	86	112	162

Q _R	3EL										4EL															
	022A	030A	031A	042A	043A	060A 061A	085A	125A	180A	250A	355A	500A	710A	022A	030A	031A	042A	043A	060A 061A	085A	125A	180A	250A	355A	500A	710A
B5	3	3,6	5	4,9	6,3	6,2	8,2	14	21	31	44	58	83	3,1	3,6	5,2	5	6,4	6,2	8,4	15	22	32	45	58	88
V1	5,9	7,1	10,1	9,8	12,6	12,5	16,5	28	42	62	88	116	166	6,2	7,3	10,3	10	12,8	12,4	16,8	30	44	64	90	116	176
V3	3,5	7,1	6	9,8	7,5	12,5	16,5	28	42	62	88	116	166	3,8	7,3	6,3	10	7,7	12,4	16,8	30	44	64	90	116	176

1) Stated oil quantities are approximate for provisioning. The exact quantity the gear reducer is to be filled with is definitely given by the level.

022A ... 710A

Mounting positions (Output mounting ... F..., ... A...)

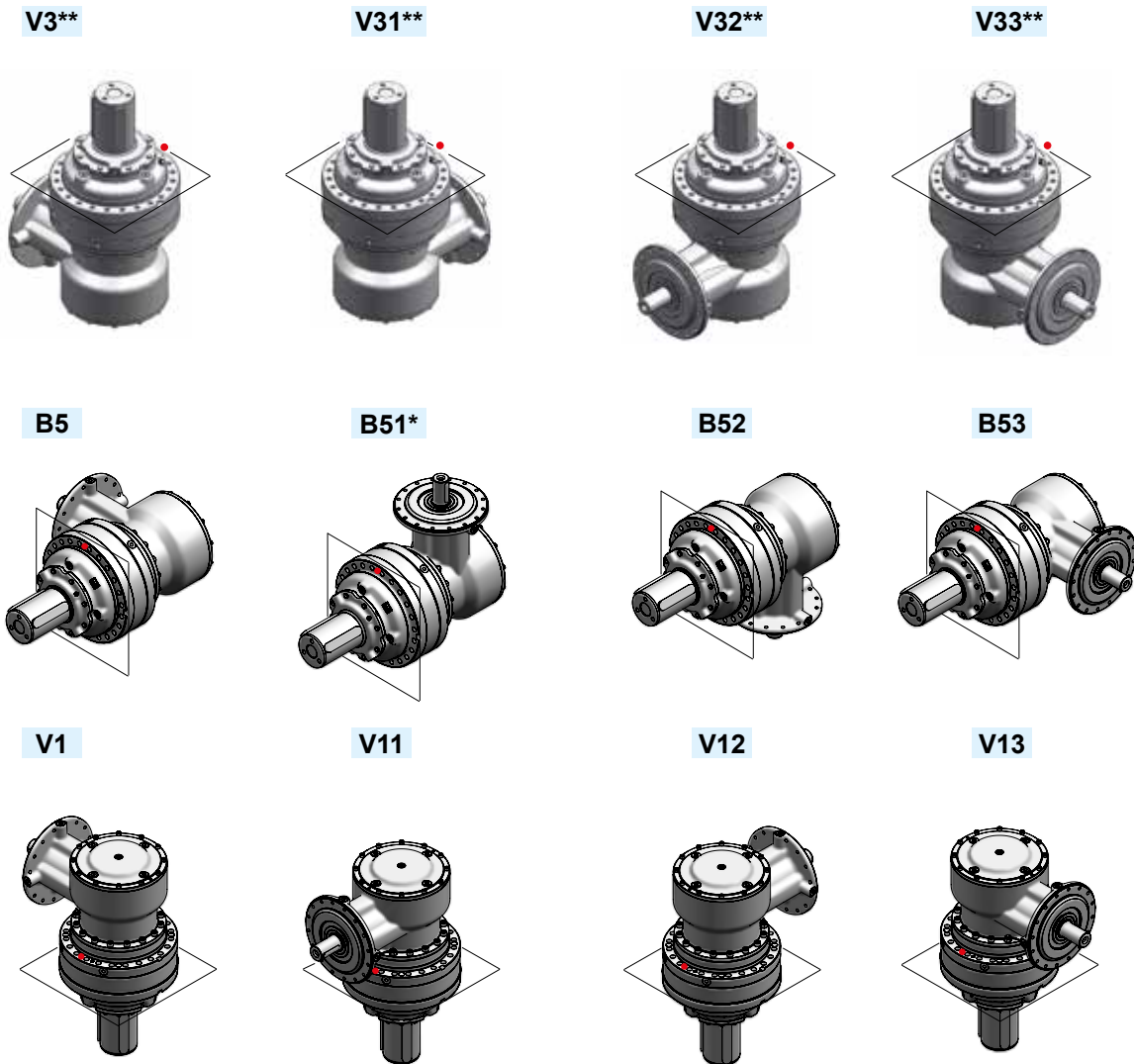

* Based on the gear reducer size and input type, the expansion tank is required (see page 6.23).

** Based on the output design, the expansion tank is required (see page 6.27).

● Reference hole for the identification of the mounting position.

Oil quantities¹⁾ [l]

Q _R	2EB								3EB								4EB																	
	022A	030A	031A	042A	043A	060A	061A	085A	125A	022A	030A	031A	042A	043A	060A	061A	085A	125A	180A	250A	355A	022A	030A	031A	042A	043A	060A	061A	085A	125A	180A	250A	355A	500A
V3 ... V33	9,7	9	12,4	18,8	15,7	20	33,5	44	5,4	9,5	8,4	12,7	10,4	18,7	18,8	38	52	82	104	4,2	9,6	7,4	11,3	9	14	22,7	32	50	66	98	122	194		
B5, B53	6	4,5	8,2	9,4	10,4	10	16,8	22	3,9	4,8	6,2	6,4	7,8	9,4	9,4	19	26	41	52	3,3	4,8	5,8	5,6	7	7	11,4	16	25	33	49	61	97		
B51	12,1	9	16,5	18,8	20,8	20	33,5	44	7,9	9,5	12,5	12,7	15,5	18,7	18,8	38	52	82	104	6,6	9,6	11,5	11,3	14,1	14	22,7	32	50	66	98	122	194		
B52	6	4,5	8,2	9,4	10,4	10	16,8	26	3,9	4,8	6,2	6,4	7,8	9,4	9,4	19	26	45	56	3,3	4,8	5,8	5,6	7	7	11,4	16	25	33	49	61	101		
V1 ... V13	9,7	9	12,4	18,8	15,7	20	33,5	31	6,4	6,7	9,7	9,9	12,7	14	15,8	32	46	69	91	5,8	8,2	10,1	9,9	12,7	12,6	19,9	29	45	63	92	116	181		

1) Stated oil quantities are approximate for provisioning. The exact quantity gear reducer is to be filled with is definitely given by the level.

Note

For the oil quantities to be filled into the gear reducers with slewing outputs (output design R-S-H), refer to the quantities stated in the previous tables for gear reducers with F output design.

The oil quantities stated are approximative for the provisioning.

The exact oil quantities to be filled into the gear reducer are given by the level.

001A ... 021A Plug positions and types

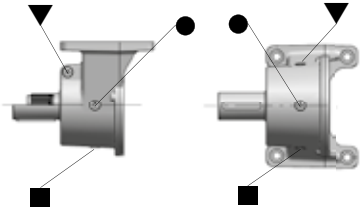

Mounting positions
B3, B5, B6, B7, B8
B32, B52, B62, B72, B82
B33, B53, B63, B73, B83

022A ... 710A Plug positions and types

Mounting positions
B5, B52, B53

- Filler plug with breather
- Transparent level plug
- Spillway plug
- Drain plug
- Expansion tank¹⁾
- Elbow

1) See page 6.23.
 2) Only for 2EB train of gears.
 3) Only for size 022A.

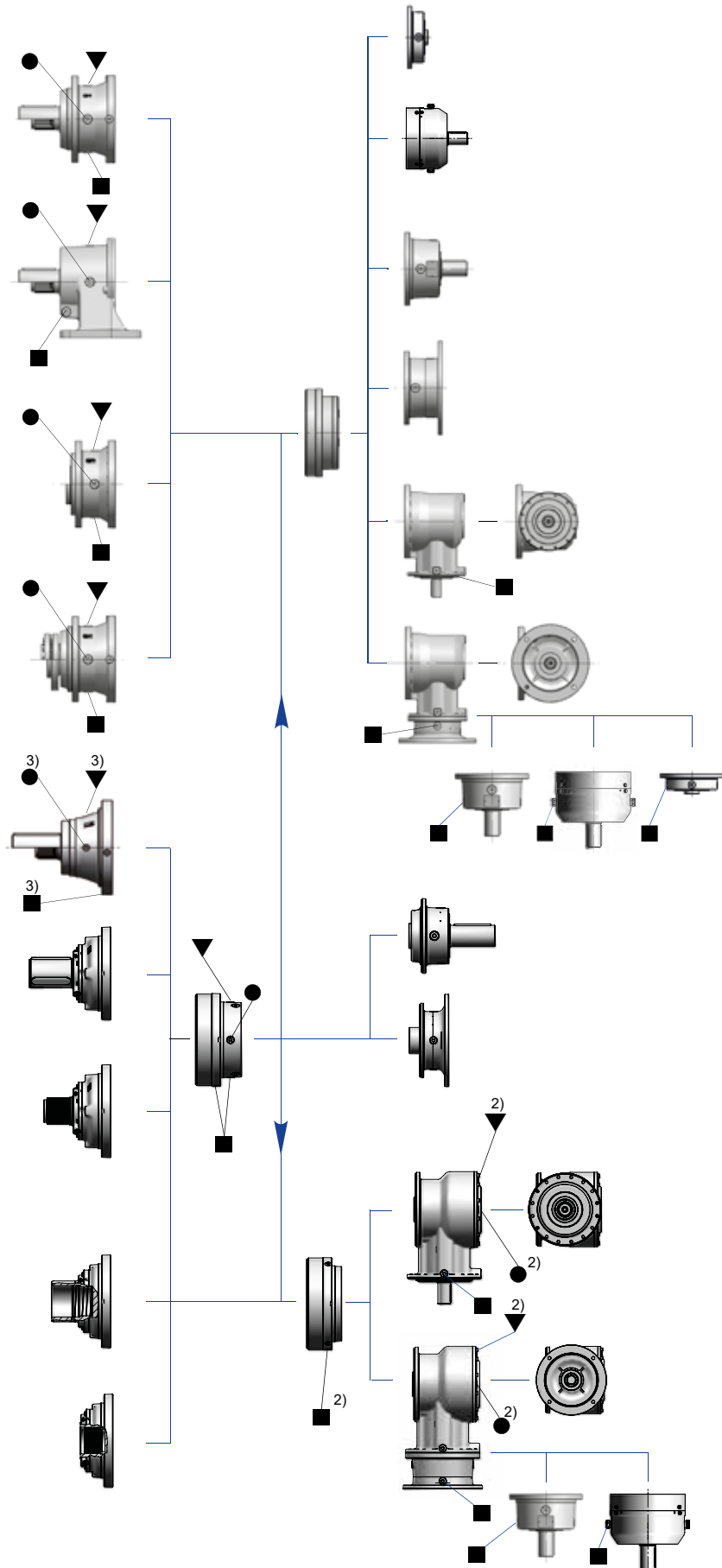

001A ... 021A Plug positions and types

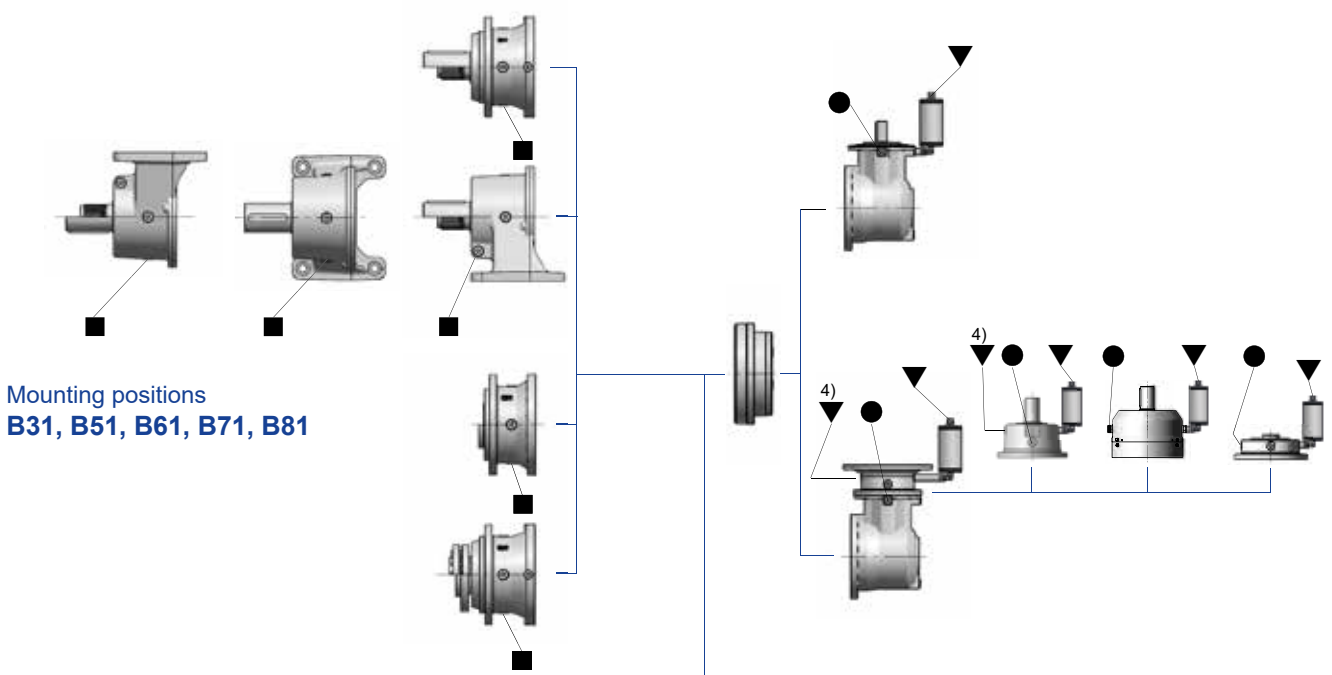

022A ... 710A Plug positions and types

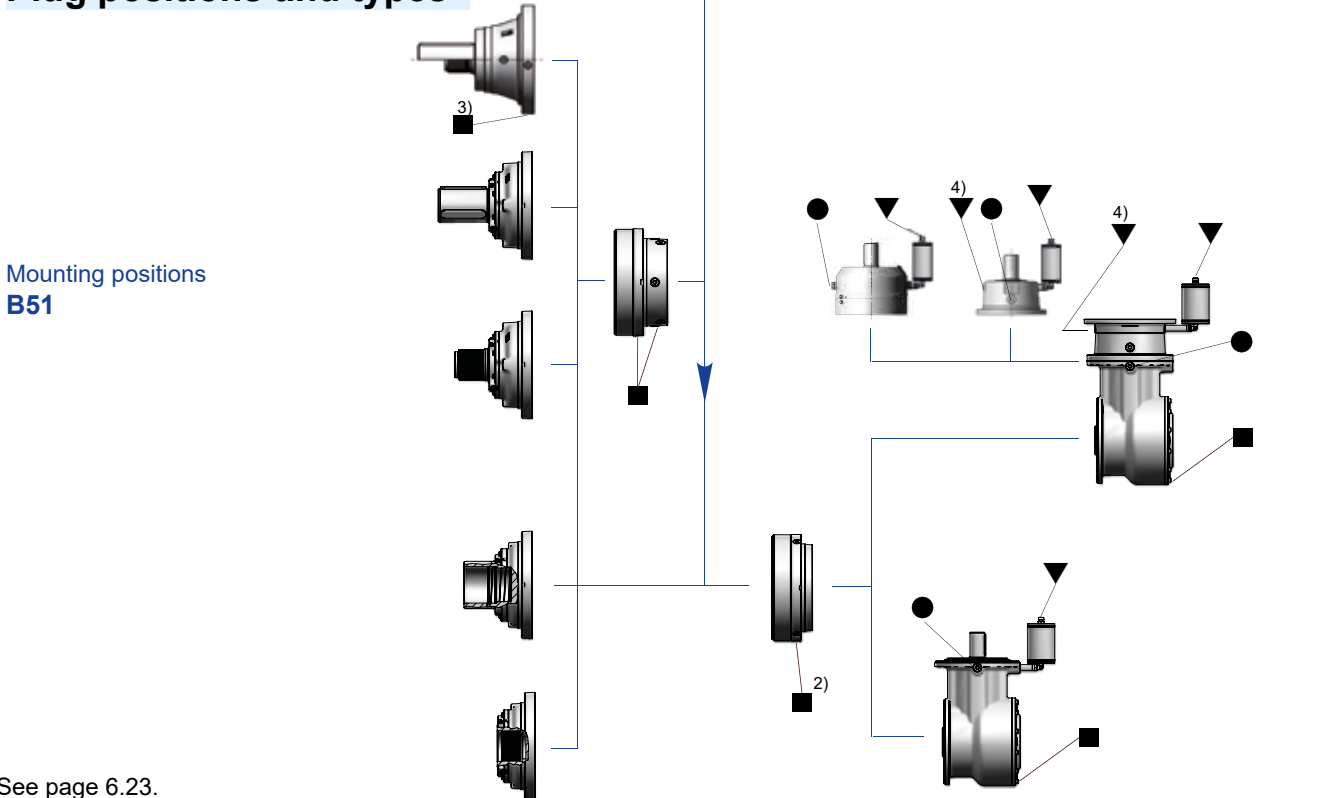

- 1) See page 6.23.
- 2) Only for 2EB train of gears.
- 3) Only for size 022A.
- 4) When expansion tank is not necessary.

001A ... 021A Plug positions and types

Mounting positions
V1, V11, V12, V13
V5, V51, V52, V53

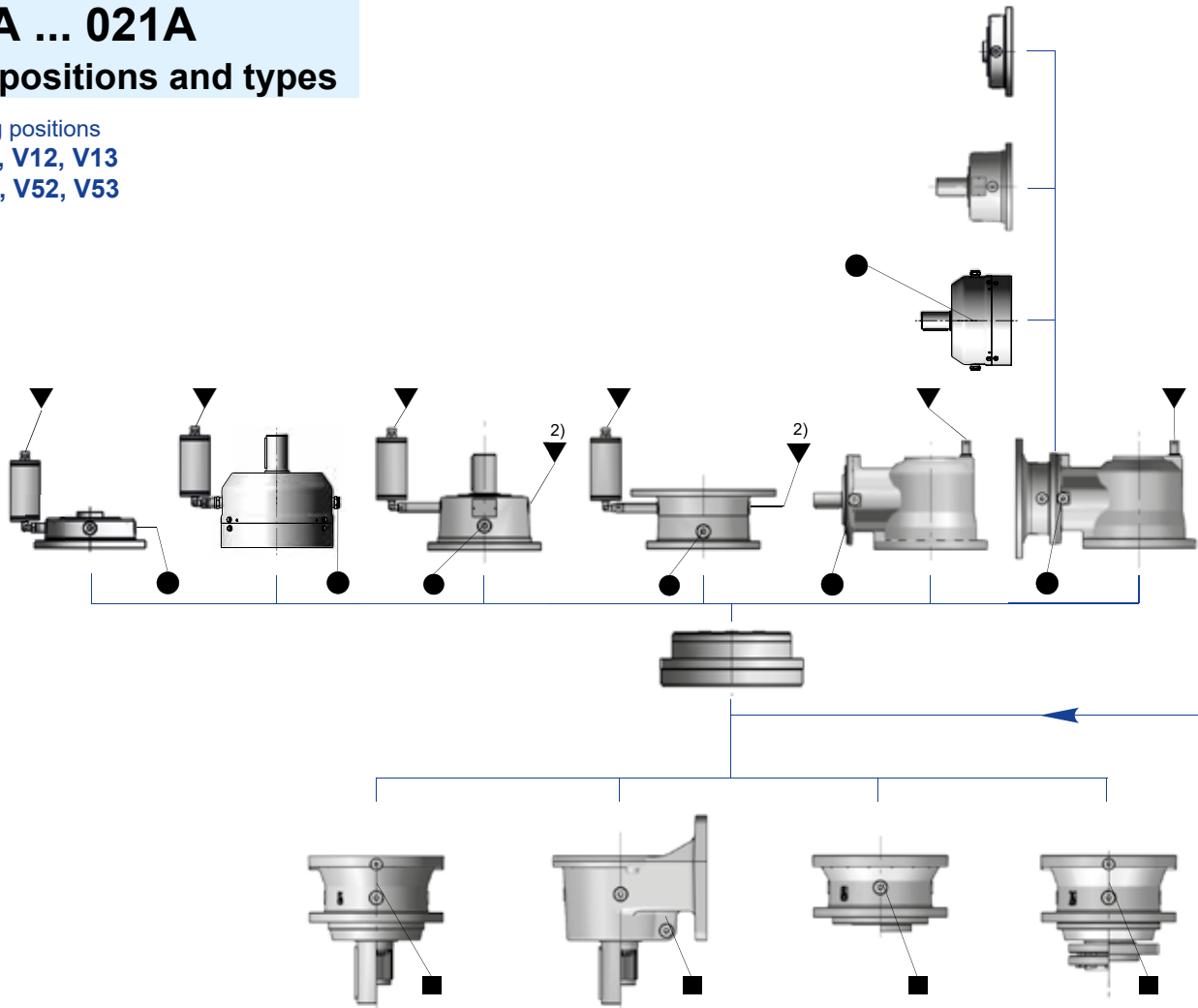

Mounting positions
V3, V31, V32, V33
V6, V61, V62, V63

- ▼ Filler plug with breather
- Transparent level plug
- ▭ Spillway plug
- Drain plug
- Expansion tank¹⁾
- Elbow

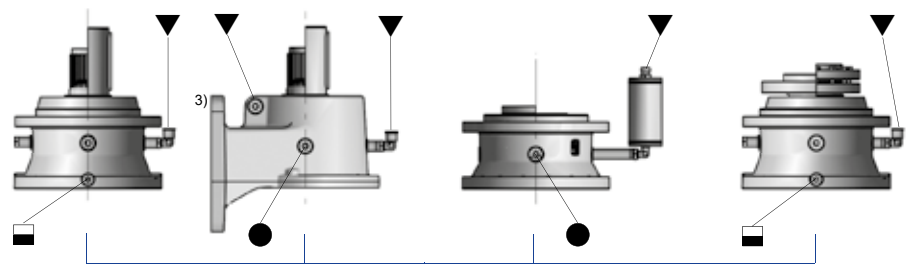

1) See page 6.23.
2) When expansion tank is not necessary.
3) Level plug only.

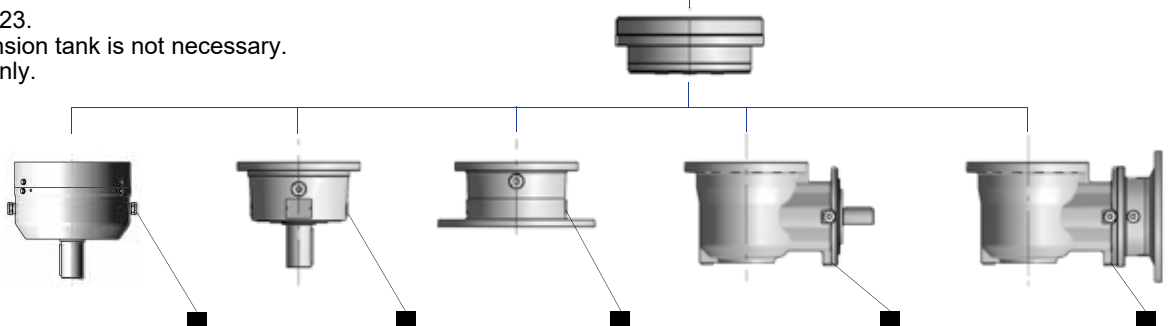

022A ... 710A Plug positions and types

Mounting positions
V1, V11, V12, V13

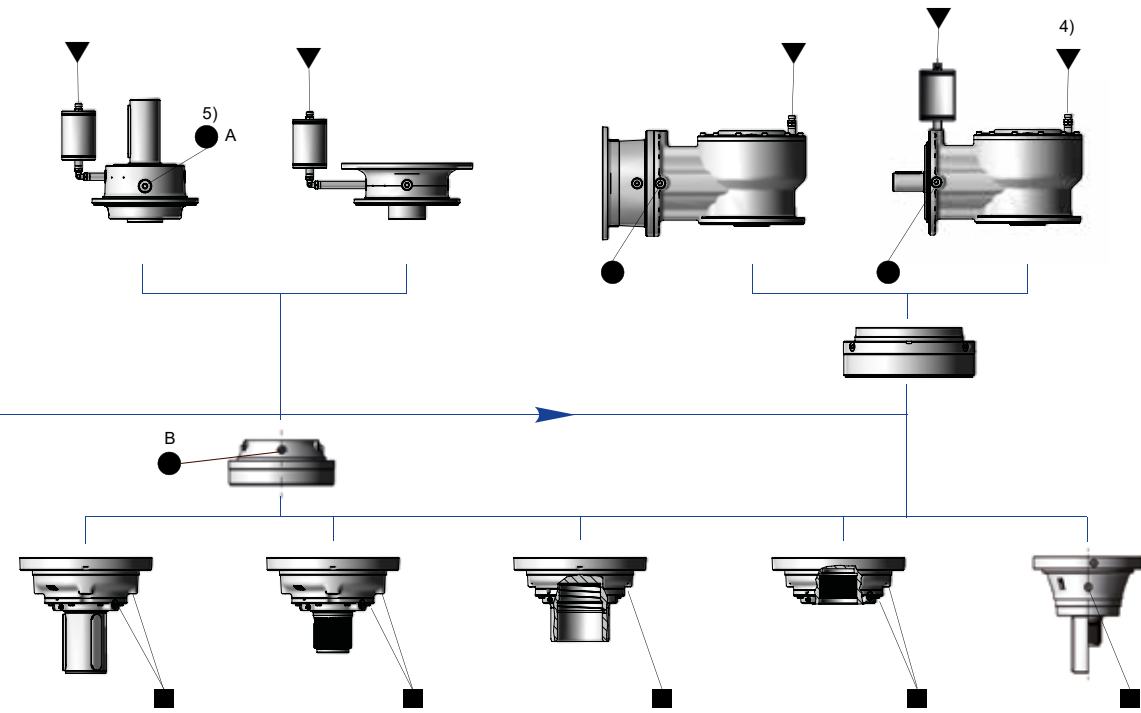

Mounting positions
V3, V31, V32, V33

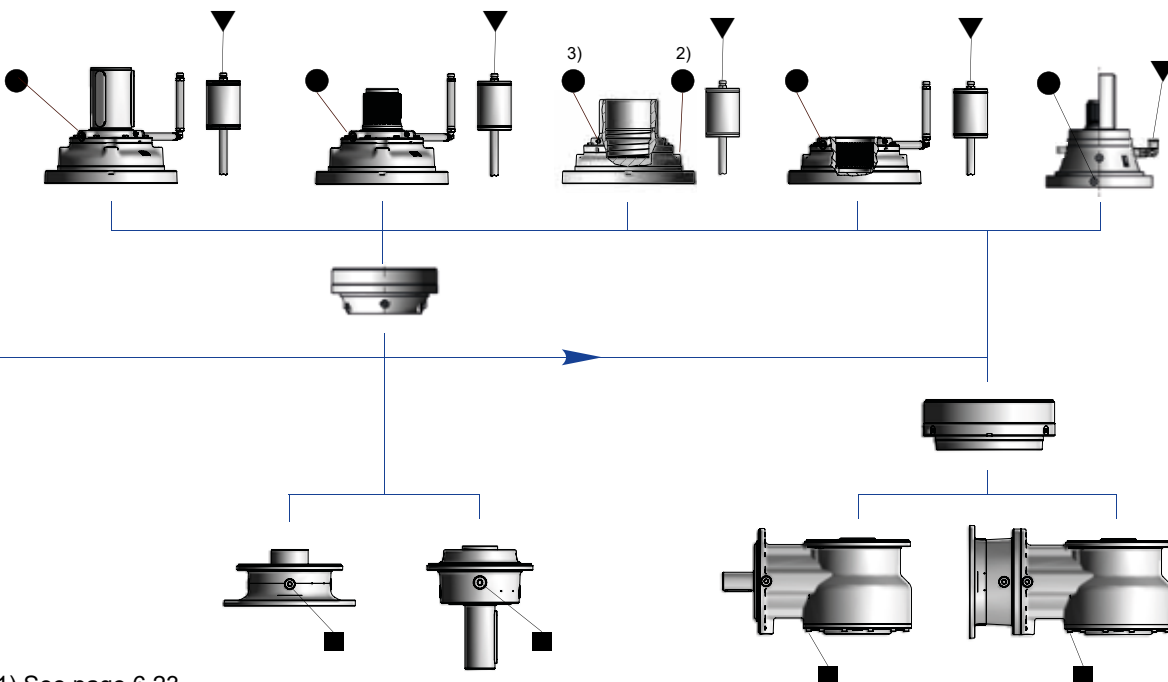

- 1) See page 6.23.
- 2) Sizes 030A, 042A and 060A.
- 3) Size \geq 085A.
- 4) When expansion tank is not necessary.
- 5) In presence of level plug marked with A, B not present.

Trouble	Possible causes	Corrective actions
Excessive temperature (in continuous duty or of bearings)	Inadequate lubrication: – excessive of insufficient oil quantity – exhaust lubricant – too tightened taper roller bearings – excessive ambient temperature	Check: – oil level (gear reducer standstill) – lubricant type – Consult Rossi Increase the cooling or correct the ambient temperature
	Obstructed suction openings of fan cover	Clean the fan cover
	Bearing failure, defect or bad lubrication	Consult Rossi
	Inefficient or out of service oil cooling system: obstructed filter, insufficient oil (exchanger) or water (coil) flow rate, pump out of service, etc.	Check the pump, the pipes, the oil filter and safety devices efficiency (manostats, thermostats, etc.)
Anomalous noise	One or more teeth with — dents or spillings — excessive flanks roughness	Consult Rossi
	Bearings failure, defect or bad lubrication	
	Taper roller bearings with excessive clearance	
Lubricant leaking from seal rings	Vibrations	Check the fastening
	Seal ring with worm, bakelized, damaged or false mounted seal lip	Replace the seal ring
	Damaged rotating seating (scoring, rust, dent, etc.)	Restore the seating
	Mounting position differs from the one stated on the name plate	Correctly position the gear reducer

NOTE

When consulting Rossi state:

- all data on gear reducer or gearmotor name plate;
- failure nature and duration;
- when and under what conditions the failure happened;
- during the warranty period, in order not to loose its validity, do not dissamble nor open the gear reducer without the approval of Rossi.

Features

The parking brakes of PB series are spring applied and hydraulic released multi-disc brakes, to be used in combination with planetary gear reducers of EP series.

They are not service brakes and they cannot be used in dynamic conditions.

They are used to hold the load from application or to stop the machine in case of emergency.

The values of static braking torque M_{Bstat} given in the following table should be considered as nominal values and are valid for a brand new brake with correct lubrication. Values of M_{Bstat} are given with a tolerance of $\pm 10\%$.

After some braking cycles, values of static braking torque could reduce by 5% and 10%, due to the adjustment of discs.

Max back pressure allowed 0,5 bar.

ATTENTION: always verify that the static braking torque M_{Bstat} referred to the gear reducer low speed shaft is lower than the value of M_{2MAX} allowed by the gear reducer itself.

Effects on the thermal power of the gear reducer

Generally, in the running conditions required by normal applications where an hydraulically released brake is present, the thermal power of the gear reducer is not exceeded.

Nevertheless, under some running conditions (high speed, continuous or frequent duty, unfavorable mounting position like V1 and V3 or similar) it is possible that the normal brake operation generate a progressive overheating of the group, influencing the thermal power allowed by the gear reducer.

In these cases it is possible to adopt solutions to reduce overheating of the brake or increase the thermal power of the group by means of an integrated cooling system or an independent cooling unit.

Consult us for further information.

Speed limits

The presence of a SAHR brake does not limit the values of n_{1max} and n_{1peak} of the gear reducer stated in EP catalog.

ATTENTION: a continuous or frequent duty at high speed may generate an overheating of the group (previous paragraph).

Operating conditions

Brakes are designed for industrial applications, at ambient temperature $-20\text{ }^{\circ}\text{C} \div +50\text{ }^{\circ}\text{C}$, maximum altitude 1 000 m. For operation at temperatures from $-20\text{ }^{\circ}\text{C}$ to $0\text{ }^{\circ}\text{C}$ limit p_{max} to 200 bar.

Functioning of PB parking brakes

Brake closed

When no pressure is applied to the brake (0 bar) springs (1) apply a force to the piston (2) which lock the discs (3) and produce a nominal braking torque equivalent to M_{Bstat} .

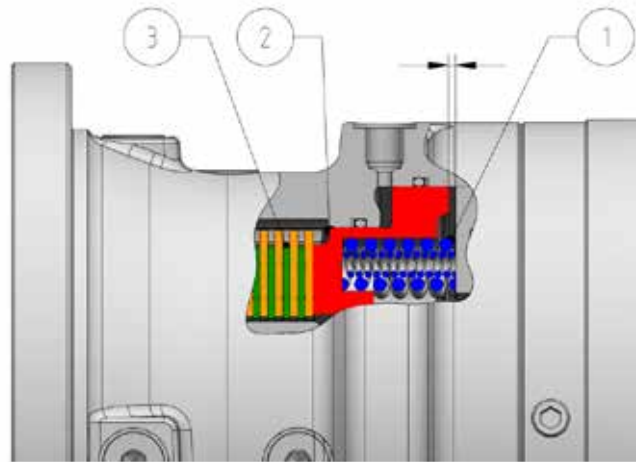

Brake opened

Above the pressure of 0 bar, the piston begins to compress the springs and the brake progressively reduces the braking torque. When the release pressure exceeds the value of p_{min} the brake begins to open; once reached the value p the brake is fully opened, the piston ends its displacement and the discs can rotate freely.

To ensure a long life of the brake, it is suggested to use a release pressure 50% above the value of p and in any case not higher than p_{max} .

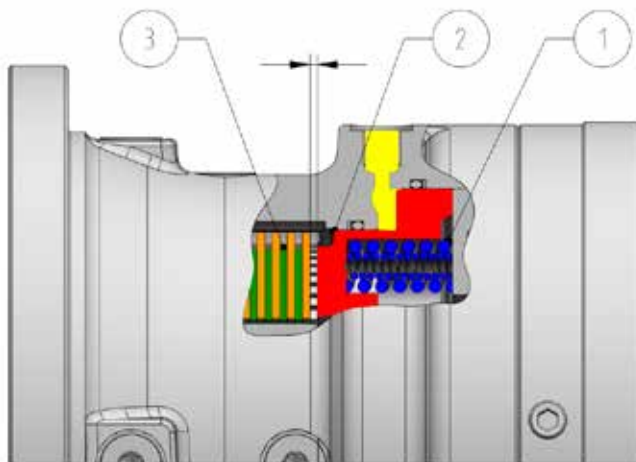

Technical data of PB parking brakes

PB10-...			0075	0150	0225	0340	0420	0525	0650	0815
Static braking torque	M_{Bstat}	[N m]	72	156	224	345	421	531	660	818
Min release pressure	p_{min}	[bar]	4,4	9,5	10,2	15,7	15,4	19,4	20,1	24,9
Release pressure	p	[bar]	6,9	14,9	16,1	24,7	24,2	30,4	31,6	39,1
Max. release pressure	p_{max}	[bar]	300							
Maximum speed	n_{1max}	[min ⁻¹]	According to gear reducer n_{1max} and n_{1peak}							
Oil volume for brake release	V	[l]	0,10							

PB30-...			0250	0400	0500	0630	0800	1000	1250	1500	1700
Static braking torque	M_{Bstat}	[N m]	265	407	509	637	809	1 010	1 281	1 529	1 741
Min release pressure	p_{min}	[bar]	7,6	11,8	11,8	14,7	15,6	19,4	24,7	25,2	28,7
Release pressure	p	[bar]	12,0	18,5	18,5	23,1	24,5	30,5	38,7	39,6	45,1
Max. release pressure	p_{max}	[bar]	300								
Maximum speed	n_{1max}	[min ⁻¹]	According to gear reducer n_{1max} and n_{1peak}								
Oil volume for brake release	V	[l]	0,12								

PB90-...			0850	1250	1500	1800	2100	2600	3000	3550	4250
Static braking torque	M_{Bstat}	[N m]	869	1 304	1 552	1 811	2 173	2 680	3 063	3 560	4 305
Min release pressure	p_{min}	[bar]	10,2	15,3	18,2	18,2	21,9	27,0	27,0	31,4	37,9
Release pressure	p	[bar]	15,3	23,0	27,4	27,4	32,8	40,5	40,5	47,1	56,9
Max. release pressure	p_{max}	[bar]	300								
Maximum speed	n_{1max}	[min ⁻¹]	According to gear reducer n_{1max} and n_{1peak}								
Oil volume for brake release	V	[l]	0,25								

Different braking torques on request.

The above performances are provided with a back pressure equal to 0 bar, any counter pressures must be considered when sizing the system.

How supplied

Nameplate of PB parking brake

Every brake is provided with a name plate in anodized aluminium containing main information necessary for a correct identification of the product; the name plate must not be removed and must be kept integral and readable. All name plate data must be specified on eventual spare part orders.

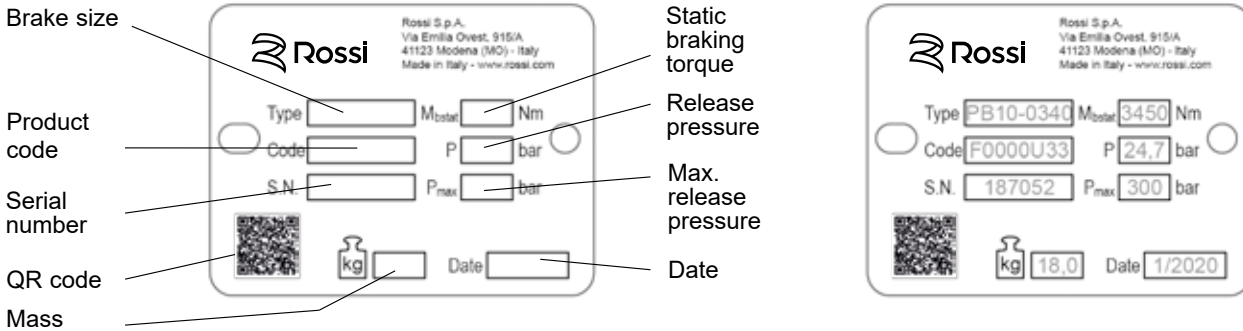

Lubrication of PB parking brakes

PB series brakes require lubrication and are supplied without oil, as specified by the relevant adhesive label. Before putting the brakes into service fill them with mineral oil ISO VG 32, unless otherwise prescribed by specific documentation. Hydraulic oils are generally suitable. The separate lubrication prevents premature lubricant contamination in the gear reducer, increasing gears and bearings life.



PB10 (001/002/C125/C160)

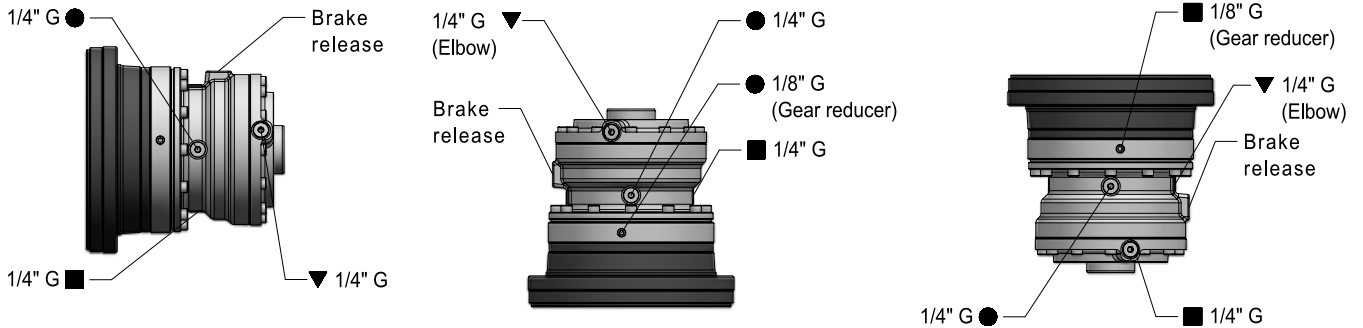

Oil quantities [l]

1EL	2EL	3EL	4EL	2EB	3EB	4EB
001A, 002A	001A...006A	001A...022A	001A...061A	001A...006A	001A...022A	001A...061A

Q _R		
B5	V1	V3
0,09	0,06	0,16

PB10 (003/004/006/C200)

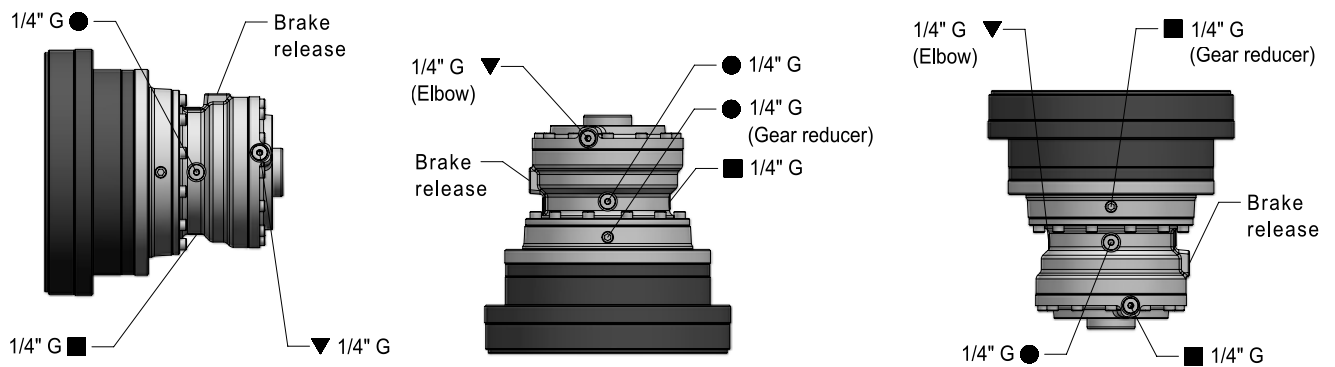

Oil quantities [l]

1EL	2EL	3EL	4EL	2EB	3EB	4EB
003A...006A	009A...022A	030A...061A	085A...180A	009A...015A, 022A	030A...043A	085A...125A

Q _R		
B5	V1	V3
0,09	0,06	0,16

PB30 (003/004/006/C200)

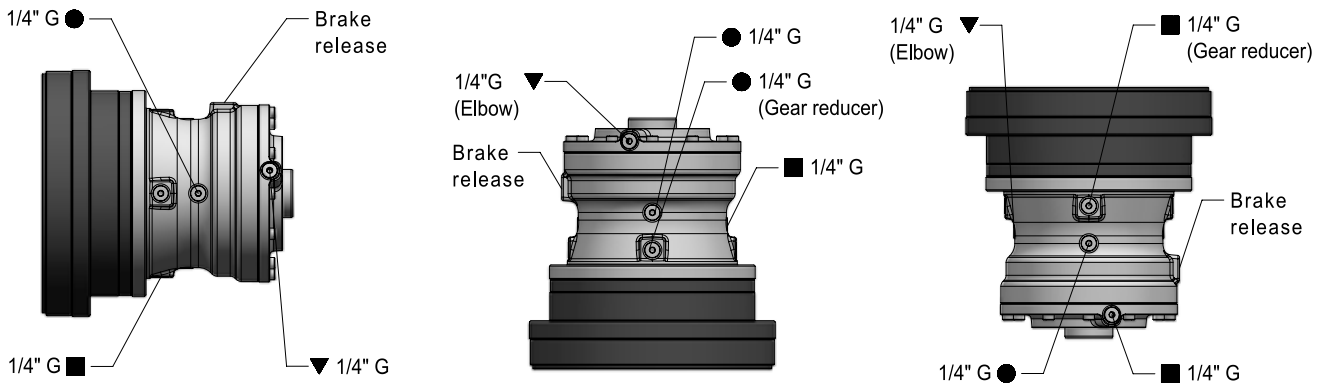

Oil quantities [l]

1EL	2EL	3EL	4EL	2EB	3EB	4EB
003A...006A	009A...022A	030A...061A	085A...180A	009A...015A, 022A	030A...043A	085A...125A

Q_R		
B5	V1	V3
0,36	0,18	0,67

PB90 (009/012/015/C250)

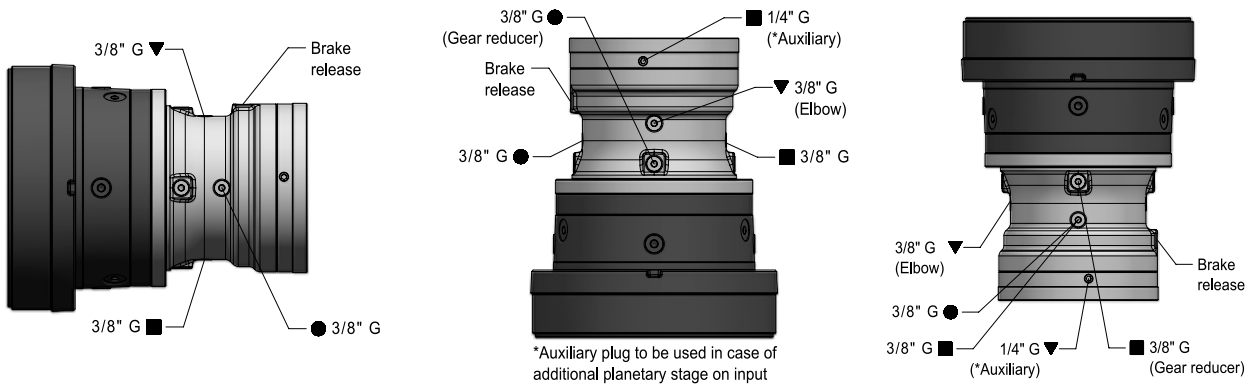

Oil quantities [l]

1EL	2EL	3EL	4EL	2EB	3EB	4EB
009A...015A	030A...043A	085A...125A	250A, 355A	018A, 021A, 030A	060A...085A	180A, 250A

Q_R		
B5	V1	V3
0,48	0,24	0,90

Oil quantity [l]

For mounting position B5 the exact oil quantity to be filled in the brake is given by the level.

For mounting positions V1, V3 apply the oil quantity stated in the tables.

Commissioning

An inadequate commissioning can damage the gear reducer, the brake and compromise the correct operation of the application. Do not disassemble and do not modify any brake component in order not to compromise the correct operation of gear reducer / brake.

Before commissioning verify that:

- gear reducer has been correctly installed and fixed to the machine
- gear reducer and brake are correctly lubricated. (oil level and grease quantity, if foreseen).
- lubricants are suitable.
- there is no lubricant leakage from plugs / seals
- oil level, drain plugs and their relevant vent valves are easily accessible
- during operation, max temperature of brake and/or gear reducer housing never exceeds admitted temperature (95°C for products on catalog)
- brake starts when machine shaft is stopped (static conditions)
- supply tube (opening and closing) is correctly connected to brake and no oil leakage is present.

For the supply of brake use mineral basis hydraulic oil; synthetic oils could damage and compromise the regular operation of brake. Connect the hydraulic circuit to drive hole present on brake, after removing the protection plug.

Before using it, purge the air. Unscrew slightly the connector on drive hole, maintaining the pressure up to complete air leakage, then screw the connector again.

- supply pressure is sufficient to open completely the brake (higher than "opening pressure [p]" differing due to braking torque and brake type)
- during brake closure phase, the supply pressure is equal to 0 bar. **Attention, eventual residual pressure in the supply tube helps to reduce the static braking torque MBstat.**
- the drive and the possible drive valve are correctly installed and connected to brake

Maintenance

All maintenance activities must be executed in safe conditions.

At machine rest, verify at regular intervals (more or less frequently according to environment and use):

- a) all external surfaces are clean and air passages to gear reducer and brake are free, in order that cooling remains fully effective. An accumulation of dust impedes efficient heat disposal
- b) oil level and deterioration degree
- c) correct fastening screws tightening.

During operation, check periodically:

- vibration and noise level
- possible oil leakages
- possible pressure losses from brake supply area (possible losses from internal brake seals).

Attention:

After a running period, gear reducer is subject to a light internal overpressure which may cause potentially burning liquid discharge. Therefore, before loosening whichever plug (filler plug included) wait until gear reducer has become cold. In all cases, always proceed with great care.

Oil change

Oil change of brake must be done according to the same gear reducer intervals.

Except specific cases, brake lubrication is separated from the gear reducer one, therefore it is necessary to act on the proper plugs present on brake.

Use only oil of the same type and viscosity and do not mix different oils.

It is advised to change lubricating oil with warm brake, to avoid any deposits and to facilitate the output.

For the operations of oil drain and filling, use the specific plugs properly.

Seal change

Change the seals when disassembling or periodically checking.

Attention:

in case of a high increase of levels when checking lubricating oils, it could be caused by an oil leakage due to brake seal wear.

In this case it is necessary to stop gear reducer / brake and contact Rossi after sale service for repair.

Troubles: causes and corrective actions

If deviations from normal operation occur, refer to the following table. If deviations persist, consult Rossi S.p.A.

Trouble	Possible cause	Corrective action
Oil leakage from seals	Seal stiffening due to long lasting storage	Clean the area and check the leakage after some hours of running
	Seal damage or wear	Consult Rossi
Multiple disc brake does not block	Residual pressure in the circuit	Verify the hydraulic circuit
	Worn discs	Consult Rossi
With running motor, gear reducer does not operate	Possible brake blocked	Verify hydraulic braking circuit
Excessive overheating	No lubricating oil	Add lubricating oil
	Disc brake does not open correctly	Verify pressure when brake opening
Multiple disc brake does not release	No pressure at brake	Verify brake connection
	Defect brake seals	Consult Rossi
Excessive vibrations	Internal trouble	Consult Rossi
Excessive noise level	Internal trouble	Consult Rossi



Rossi

Solutions for
an evolving
industry

HEADQUARTERS

Rossi S.p.A.

Via Emilia Ovest 915/A
41123 Modena - Italy

info@rossi.com
www.rossi.com

UTD.175.09-2022.00_EN

© Rossi S.p.A. Rossi reserves the right to make any modification whenever to this publication contents. The information given in this document only contains general descriptions and/or performance features which may not always specifically reflect those described.

The Customer is responsible for the correct selection and application of product in view of its industrial and/or commercial needs, unless the use has been recommended by technical qualified personnel of Rossi, who were duly informed about Customer's application purposes. In this case all the necessary data required for the selection shall be communicated exactly and in writing by the Customer, stated in the order and confirmed by Rossi. The Customer is always responsible for the safety of product applications. Every care has been taken in the drawing up of the catalog to ensure the accuracy of the information contained in this publication, however Rossi can accept no responsibility for any errors, omissions or outdated data. Due to the constant evolution of the state of the art, Rossi reserves the right to make any modification whenever to this publication contents. The responsibility for the product selection is of the Customer, excluding different agreements duly legalized in writing and undersigned by the Parties.