

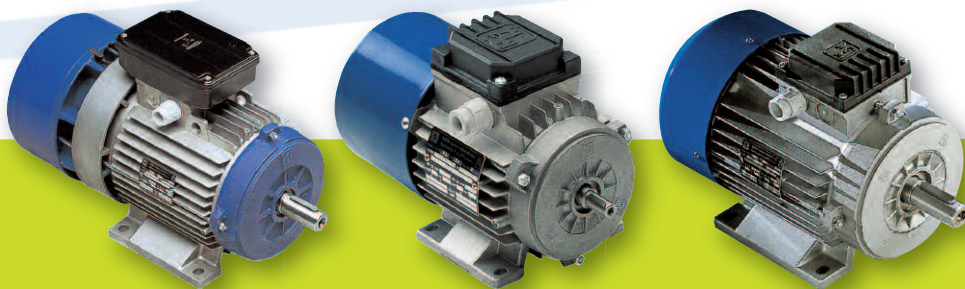

MGM



ENGLISH

BAX-BA SERIES

- Brake Motors
- IEC Metric Motors from 71 to 280 frame size
- Motors with NEMA dimensioned shafts and flanges available
- BAX Series comply with Premium (IE3) efficiency class (CC051A)
- Totally Enclosed Fan Cooled (TEFC)
- IP54 enclosure (IP55 and IP56 on request)
- F class insulation (H class on request)
- Continuous Duty BAX
- Intermittent Duty BA
- 230/460V 60Hz, 575V 60Hz or 230/400V 50Hz for Europe
- AC and DC Brake
- Very high brake torque
- Heavy Duty Cycle
- Low Maintenance
- Aluminum frame up to 132 frame size, cast iron from 160 to 280 frame size
- Cast iron flanges starting from 100 frame size
- Screw in style brake release
- Hex hole on nondrive shaft end for manual rotation (on request starting from 160 frame size)
- cCSAus approved ()
- **CE** mark for Europe

BMX-BM SERIES

- Brake Motors
- IEC Metric Motors from 56 to 225 frame size
- Motors with NEMA dimensioned shafts and flanges available
- BMX Series comply with Premium (IE3) efficiency class (CC051A)
- Totally Enclosed Fan Cooled (TEFC)
- IP54 enclosure (IP55 and IP56 on request)
- F class insulation (H class on request)
- Continuous Duty BMX
- Intermittent Duty BM
- 230/460V 60Hz, 575V 60Hz or 230/400V 50Hz for Europe
- DC Brake
- Low noise brake
- Aluminum frame up to 132 frame size, cast iron from 160 to 225 frame size
- Cast iron flange starting from 100 frame size
- cCSAus approved ()
- **CE** mark for Europe

Brake motor applications:

Any application requiring quick start and stop; machine tools, conveyors, palletizers, packaging machinery, textile machinery, speed reducers, cranes, ceramic and tile machinery, wood machinery, indexing tables, and automatic doors.

SMX-SM SERIES

- AC Three phase squirrel cage induction motors
- IEC Metric Motors from 56 to 280 frame size
- Motors with NEMA dimensioned shafts and flanges available
- SMX Series comply with Premium (IE3) efficiency class (CC051A)
- Totally Enclosed Fan Cooled (TEFC)
- IP55 enclosure (IP56 on request)
- F class insulation (H class on request)
- Continuous Duty SMX
- Intermittent Duty SM
- 230/460V 60Hz, 575V 60Hz
- IP55 Enclosure
- Aluminum frame up to 132 frame size, cast iron from 160 to 225 frame size
- Cast iron flange starting from 100 frame size
- cCSAus approved ()
- **CE** mark for Europe

Three phase motor applications:

Pumps, fans, packaging machinery, conveyors, machine tools, gear reducers and other applications.

The following options are also available:

- High moment of inertia Flywheel for traversing - PV (BAPV, BMPV Series)
- Forced Cooling - SV, - AV (BASV, BMAV, SMAV Series)
- Built-in Encoder - E (BAE, BME, SME Series)

Please refer to MGM general catalog for further technical details.

FRANÇAIS

LA SÉRIE BAX-BA

- Moteurs freins asynchrones triphasés
- Moteurs métriques de hauteur d'axe de 71 à 280 mm-standard IEC
- Moteurs avec dimensions NEMA disponible pour l'arbre et la bride
- La série BAX est en conformité avec la classe d'efficacité Premium (IE3) - Numéro de certification de conformité CC051A.
- Totalement fermés, ventilation externe
- Classe de protection IP54 (IP55 et IP56 sur demande)
- Classe F d'isolation (class H sur demande)
- Fonctionnement continue BAX
- Service intermittent BA
- 230/460V 60Hz, 575V 60Hz ou 230/400V 50Hz (Europe)
- Frein à courant alternatif (AC) ou courant continu (DC)
- Couple de freinage très élevé
- Fonctionnement en conditions sévères
- Faible entretien
- Carcasse en aluminium jusqu'au moteur 132 et en fonte de 160 à 280 mm
- Bride en fonte pour la hauteur d'axe à partir de 100 mm
- Vis pour desserrage manuel du frein
- Trou hexagonal, de bout d'arbre, pour la rotation manuelle (sur demande pour les moteurs 160 et plus)
- Approuvé par cCSAus () pour le Canada et les Etats-Unis
- Marque **CE** pour l'Europe

LA SÉRIE BMX-BM

- Moteurs freins asynchrones triphasés
- Moteurs métriques de hauteur d'axe de 56 à 225 mm-standard IEC
- Moteurs avec dimensions NEMA disponible pour l'arbre et la bride
- La série BMX est en conformité avec la classe d'efficacité Premium (IE3) - Numéro de certification de conformité CC051A.
- Totalement fermés, ventilation externe
- Classe de protection IP54 (IP55 et IP56 sur demande)
- Classe F d'isolation (class H sur demande)
- Fonctionnement continue BMX
- Service intermittent BM
- 230/460V 60Hz, 575V 60Hz ou 230/400V 50Hz (Europe)
- Frein à courant continu (DC)
- Frein à faible bruit
- Carcasse en aluminium jusqu'au moteur 132 et en fonte de 160 à 225 mm
- Bride en fonte pour la hauteur d'axe à partir de 100 mm
- Approuvé par cCSAus () pour le Canada et les Etats-Unis
- Marque **CE** pour l'Europe

Le domaine d'application des moteurs freins asynchrones triphasés

Particulièrement adaptés aux applications qui exigent des démarrages et arrêts rapides; machines-outils, convoyeurs, palettiseurs, machines d'emballage, machines pour tissu, céramique, tuiles et bois, réducteurs de vitesse, grues, plateaux diviseurs, portes automatiques.

LA SÉRIE SMX-SM

- Moteurs asynchrones triphasés
- Moteurs métriques de hauteur d'axe de 56 à 280 mm-standard IEC
- Moteurs avec dimensions NEMA disponible pour l'arbre et la bride
- La série SMX est en conformité avec la classe d'efficacité Premium (IE3) - Numéro de certification de conformité CC051A.
- Totalement fermés, ventilation externe
- Classe de protection IP55 (IP56 sur demande)
- Classe F d'isolation (class H sur demande)
- Fonctionnement continue SMX
- Service intermittent SM
- 230/460V 60Hz, 575V 60Hz
- Carcasse en aluminium jusqu'au moteur 132 et en fonte de 160 à 225 mm
- Bride en fonte pour la hauteur d'axe à partir de 100 mm
- Approuvé par cCSAus () pour le Canada et les Etats-Unis
- Marque **CE** pour l'Europe

Le domaine d'application de moteurs asynchrones triphasés

Pompes, ventilateurs, machines d'emballage, convoyeurs, machines-outils, réducteurs de vitesse et d'autres applications exigeant des moteurs métriques - standard IEC.

Sont également disponibles les options suivantes:

- Moment d'inertie élevé réalisé avec un volant, pour traverses - PV (les séries BAPV et BMPV)
- Ventilation forcée - SV, AV (les séries BASV, BMAV et SMAV)
- Encodeur intégré - E (les séries BAE, BME et SME)

Pour tous détails techniques, veuillez consulter le Catalogue Général de MGM.

BAX-BA Series

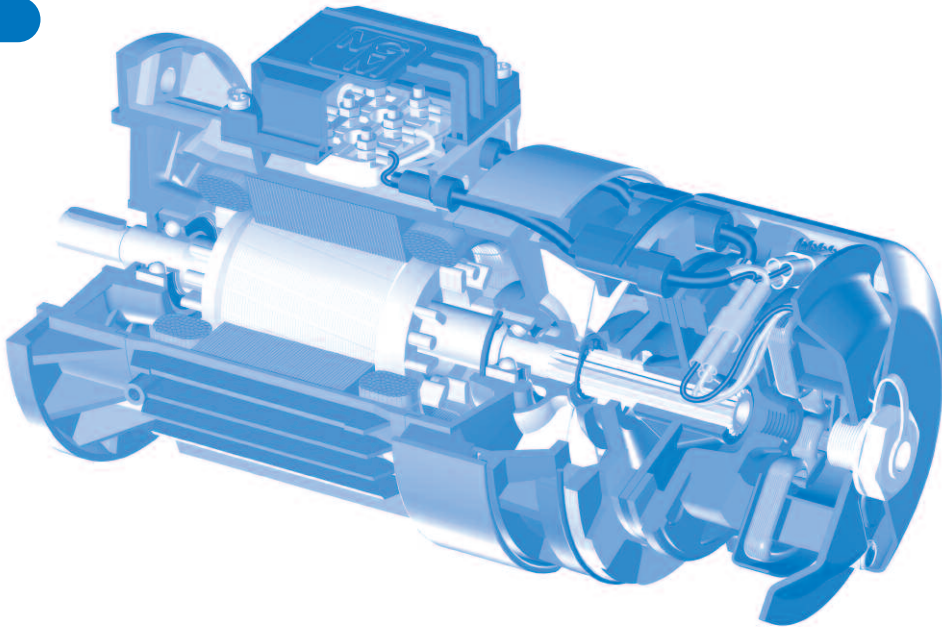

BMX-BM Series

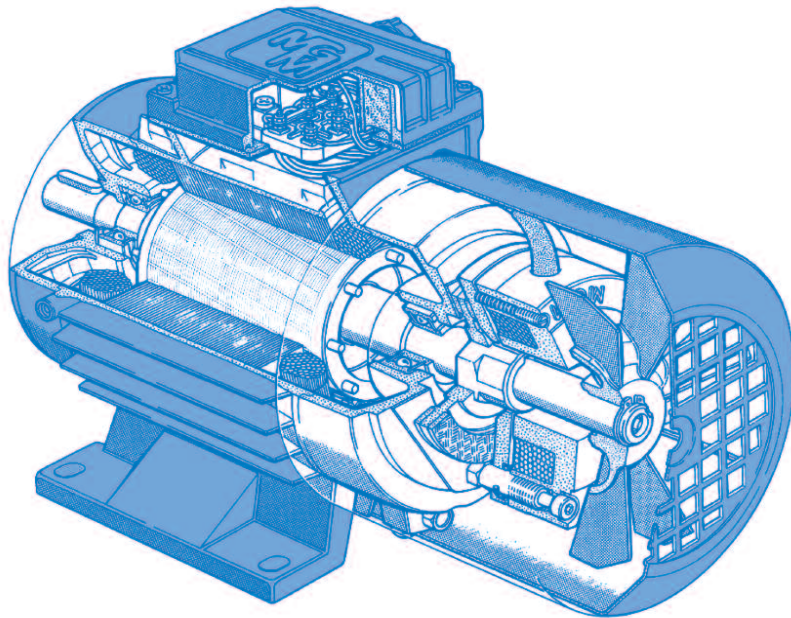

SMX-SM Series

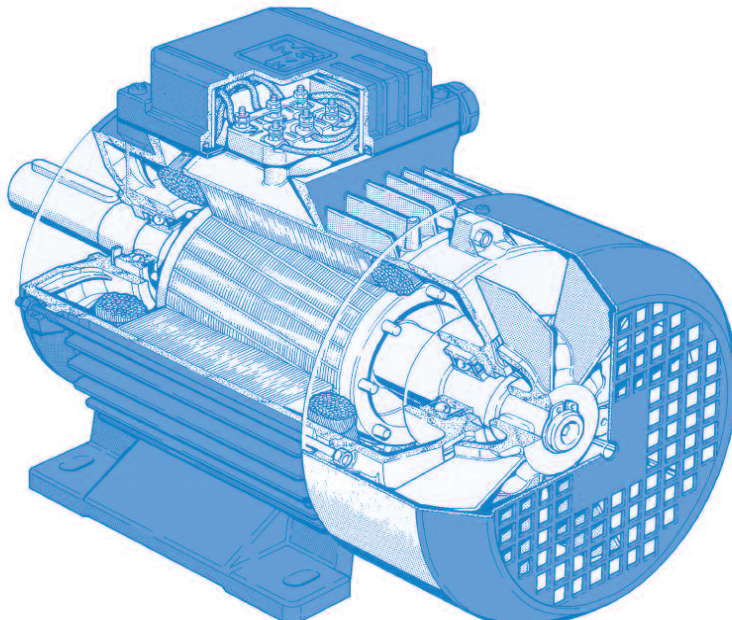



TYPE	2 pole	4 pole	6 pole	8 pole	2 / 4 pole	4 / 8 pole	2 / 6 pole	2 / 8 pole	4 / 6 pole	4 / 12 pole (S3 40%)	2 / 12 pole (S3 40%)	4 / 16 pole (S4 40% - 4 pole S4 25% - 16 pole)
56 A	0.09 0.12	0.06 0.08										
56 B	0.12 0.16	0.09 0.12	0.06 0.08									
63 A	0.18 0.25	0.12 0.16										
63 B	0.25 0.33	0.18 0.25			0.22/0.15 0.30/0.20							
63 C	0.37 0.50	0.22 0.30	0.09 0.12		0.26/0.17 0.36/0.22			0.18/0.04 0.25/0.05				
63 D		0.30 0.40	0.12 0.16	0.07 0.10								
71 A	0.37 0.50	0.25 0.33	0.18 0.25	0.08 0.11	0.25/0.18 0.33/0.25	0.13/0.07 0.17/0.10						
71 B	0.55 0.75	0.37 0.50	0.25 0.33	0.11 0.14	0.37/0.25 0.50/0.33	0.18/0.09 0.25/0.12	0.25/0.08 0.33/0.11	0.25/0.06 0.33/0.08				
71 C	0.75 1.00	0.55 0.75				0.22/0.12 0.30/0.16	0.35/0.10 0.47/0.13	0.35/0.07 0.47/0.10	0.18/0.11 0.25/0.14			
71 D		0.65 0.88										
80 A	0.75 1.00	0.55 0.75	0.37 0.50	0.18 0.25	0.65/0.45 0.88/0.61	0.25/0.18 0.33/0.25	0.37/0.12 0.50/0.16	0.37/0.09 0.50/0.12	0.25/0.18 0.33/0.25	0.25/0.05 0.33/0.06		
80 B	1.10 1.50	0.75 1.00	0.55 0.75	0.25 0.33	0.88/0.62 1.18/0.83	0.37/0.25 0.50/0.33	0.55/0.18 0.75/0.25	0.55/0.12 0.75/0.16	0.37/0.25 0.50/0.33	0.37/0.07 0.50/0.10	0.45/0.07 0.61/0.10	
80 C		0.90 1.20										
90 SA	1.50 2.00	1.10 1.50	0.75 1.00	0.37 0.50		0.75/0.37 1.00/0.50	0.90/0.30 1.20/0.40		0.55/0.37 0.75/0.50	0.40/0.13 0.54/0.17		
90 SB					1.30/0.90 1.75/1.20			0.75/0.18 1.00/0.25			0.75/0.11 1.00/0.14	
90 LA	2.20 3.00	1.50 2.00	1.10 1.50	0.55 0.75	1.80/1.20 2.50/1.60		1.20/0.40 1.60/0.54	1.10/0.25 1.50/0.33		0.55/0.18 0.75/0.25	1.10/0.15 1.50/0.20	
90 LB		1.85 2.50	1.30 1.75	0.65 0.88	2.20/1.50 3.00/2.00	1.10/0.60 1.50/0.82	1.40/0.50 1.90/0.68	1.30/0.30 1.75/0.40	0.75/0.55 1.00/0.75	0.75/0.22 1.00/0.30		
90 LC		2.20 3.00										
100 LA	3.00 4.00	2.20 3.00	1.50 2.00	0.75 1.00	2.20/1.50 3.00/2.00		1.60/0.60 2.20/0.82	1.60/0.40 2.20/0.54	1.10/0.80 1.50/1.10	0.90/0.25 1.20/0.33		
100 LB		3.00 4.00	1.85 2.50	1.10 1.50	3.10/2.30 4.10/3.10	1.60/0.90 2.20/1.20	2.20/0.80 3.00/1.10	2.20/0.50 3.00/0.68	1.50/1.00 2.00/1.34	1.10/0.35 1.50/0.47	1.85/0.25 2.50/0.33	
112 MB	4.00 5.50	4.00 5.50	2.20 3.00	1.50 2.00	4.50/3.30 6.10/4.40	2.20/1.20 3.00/1.60	3.00/1.00 4.00/1.34	3.00/0.80 4.00/1.10	2.00/1.30 2.70/1.75	1.50/0.45 2.00/0.61	3.00/0.45 4.00/0.61	
112 MBX		5.00 6.70										
132 SA	5.50 7.50									2.50/0.80 3.40/1.10		
132 SB	7.50 10.00	5.50 7.50	3.00 4.00	2.20 3.00	5.00/4.50 6.70/6.10	3.00/2.00 4.00/2.70	4.00/1.30 5.50/1.75	4.00/1.10 5.50/1.50	2.20/1.50 3.00/2.00		4.00/0.65 5.50/0.88	
132 MA	9.20 12.50	7.50 10.00	4.00 5.50		6.00/5.00 8.00/6.70	4.00/2.70 5.50/3.60	5.50/1.80 7.50/2.50	5.50/1.50 7.50/2.00	3.00/2.20 4.00/3.00	3.00/1.00 4.00/1.34	5.50/0.90 7.50/1.20	2.80/0.70 3.70/0.95
132 MB	11.00 15.00	9.20 12.50	5.50 7.50	3.00 4.00	7.50/6.00 10.00/8.00	6.00/4.00 8.00/5.50	7.00/2.20 9.50/3.00	7.00/1.80 9.50/2.50	3.70/2.50 5.00/3.40	4.00/1.30 5.50/1.75	7.00/1.10 9.50/1.50	4.00/1.10 5.50/1.50
132 MC				4.00 5.50								
160 MA	11.00 15.00	9.20 12.50			9.50/8.00 12.70/10.90							5.50/1.30 7.50/1.75
160 MB	15.00 20.00	11.00 15.00	7.50 10.00	5.50 7.50	11.00/9.00 15.00/12.00	6.50/4.50 8.80/6.10	8.00/2.50 10.90/3.40	8.00/2.20 10.90/3.00	5.50/3.70 7.50/5.00	4.80/1.60 6.60/2.20	8.00/1.30 10.90/1.75	7.30/1.80 9.80/2.50
160 LA	18.50 25.00	15.00 20.00	9.20 12.50	7.50 10.00	13.00/11.00 17.40/15.00	9.50/6.00 12.70/8.00	11.00/3.60 15.00/4.80	11.00/3.00 15.00/4.00			11.00/1.80 15.00/2.50	
160 LB			11.00 15.00						7.50/5.00 10.00/6.70	7.30/2.40 9.80/3.20		10.00/2.50 13.40/3.40
180 LA	22.00 30.00	18.50 25.00			17.00/14.00 22.80/18.80	11.00/8.00 15.00/10.90						13.20/3.00 18.00/4.00
180 LB		22.00 30.00	15.00 20.00	11.00 15.00	20.50/17.00 27.50/22.80	14.00/9.00 18.80/12.00	16.00/6.50 21.70/8.80	16.00/4.00 21.70/5.50	13.00/8.80 17.40/11.80		16.00/2.60 21.70/3.50	
200 LA	30.00 40.00		18.50 25.00	15.00 20.00		18.00/11.00 24.00/15.00					18.5/3.00 25.00/4.00	
200 LB	37.00 50.00	30.00 40.00	22.00 30.00		24.00/20.00 32.20/26.80	21.00/13.00 28.20/17.40		18.50/4.50 25.00/6.10				16.00/4.00 21.40/5.50
225 S		37.00 50.00										19.00/4.80 25.30/6.60
225 M		45.00 60.00	30.00 40.00	22.00 30.00								24.00/6.00 32.20/8.00
225 MX			37.00 50.00									
250 M		55.00 75.00	37.00 50.00									
280 S		75.00 100.00	45.00 60.00									
280 M		90.00 120.00	55.00 75.00									

Please refer to MGM Internet site for further information on the available motor power
 Veuillez vous référer au site Internet de MGM pour de plus amples informations sur la puissance disponible des moteurs

Series	Motor type	Power		RPM	In (A) 230V 60Hz	In (A) 460V 60Hz	In (A) 575V 60Hz	cos φ 100%	Eff. 100%	Eff. 75%	Eff. 50%	Tn		Ts/Tn	Is/In	Code
		Hp	kW									Nm	lb In			
2 pole - 3600 RPM																
BAX-BMX-SMX	80 A2	1.0	0.75	3465	3.12	1.56	1.25	0.75	77.00	79.30	74.70	2.08	18.4	4.9	8.0	L
BAX-BMX-SMX	90 SA2	1.5	1.1	3540	4.50	2.25	1.80	0.74	84.00	82.40	77.90	2.97	26.3	5.1	11.6	R
BAX-BMX-SMX	90 LA2	2.0	1.5	3535	5.80	2.90	2.30	0.74	85.50	85.00	81.20	4.05	35.8	6.2	11.4	P
BAX-BMX-SMX	100 LA2	3.0	2.2	3532	8.00	4.00	3.20	0.78	86.50	87.56	85.00	5.94	52.6	5.6	10.0	M
BAX-BMX-SMX	112 MC2	5.0	3.7	3550	12.9	6.45	5.20	0.83	88.50	89.20	87.40	9.95	88.1	6.0	12.4	P
BAX-BMX-SMX	132 SA2	7.5	5.5	3550	18.8	9.40	7.50	0.82	89.50	88.00	86.70	14.8	131.0	6.1	10.6	M
BAX-BMX-SMX	132 SB2	10.0	7.5	3550	24.8	12.4	9.90	0.82	90.20	91.00	89.10	20.2	178.8	6.2	11.3	M
BAX-BMX-SMX	160 MA2	15.0	11.0	3562	36.0	18.0	14.4	0.85	91.00	89.20	88.60	29.5	261.1	5.8	13.9	P
BAX-BMX-SMX	160 MB2	20.0	15.0	3562	47.0	23.5	18.8	0.88	91.00	90.70	89.30	40.2	355.8	4.2	10.6	L
BAX-BMX-SMX	160 LA2	25.0	18.5	3562	58.2	29.1	23.3	0.86	91.70	92.90	91.30	49.6	439.0	4.8	11.5	M
BAX-BMX-SMX	180 LA2	30.0	22.0	3565	68.6	34.3	27.4	0.88	91.70	92.80	91.20	58.9	521.3	5.1	11.7	M
BAX-BMX-SMX	200 LA2	40.0	30.0	3566	94.8	47.4	37.9	0.86	92.40	92.50	91.30	80.3	710.7	6.2	13.3	P
BAX-BMX-SMX	200 LB2	50.0	37.0	3564	113.6	56.8	45.4	0.88	93.00	93.20	92.60	99.1	877.1	5.0	11.1	M
4 pole - 1800 RPM																
BAX-BMX-SMX	80 B4	1.0	0.75	1730	3.20	1.60	1.30	0.70	85.50	85.40	83.40	4.14	36.6	3.6	6.6	K
BAX-BMX-SMX	90 SA4	1.5	1.1	1739	4.60	2.30	1.84	0.68	86.50	85.60	83.30	6.04	53.5	4.1	7.0	K
BAX-BMX-SMX	90 LA4	2.0	1.5	1739	6.20	3.10	2.50	0.70	86.50	86.50	84.20	8.2	72.6	4.1	7.1	K
BAX-BMX-SMX	100 LA4	3.0	2.2	1750	8.60	4.30	3.44	0.73	89.50	88.90	87.00	12.0	106.2	4.1	7.4	K
BAX-BMX-SMX	112 MB4	4.0	3	1757	11.2	5.60	4.50	0.75	89.50	89.40	87.40	16.3	144.3	4.2	10.0	M
BAX-BMX-SMX	112 MC4	5.0	3.7	1757	14.0	7.00	5.60	0.73	89.50	89.40	87.10	20.1	177.9	4.0	10.0	N
BAX-BMX-SMX	132 SB4	7.5	5.5	1765	19.6	9.80	7.84	0.77	91.70	90.70	89.30	29.8	263.8	4.0	8.7	L
BAX-BMX-SMX	132 MA4	10.0	7.5	1765	26.4	13.2	10.6	0.78	91.70	92.00	91.10	40.6	359.3	3.7	9.1	L
BAX-BMX-SMX	160 MA4	12.5	9.2	1770	33.2	16.6	13.3	0.76	91.70	92.10	90.60	49.6	439.0	5.0	11.1	N
BAX-BMX-SMX	160 MB4	15.0	11.0	1768	37.6	18.8	15.0	0.80	92.40	92.90	92.40	59.4	525.7	4.2	9.8	L
BAX-BMX-SMX	160 LA4	20.0	15.0	1768	52.6	26.3	21.0	0.77	93.00	93.20	93.00	81.0	716.9	4.1	8.0	K
BAX-BMX-SMX	180 LA4	25.0	18.5	1778	65.2	32.6	26.1	0.76	93.60	93.30	92.00	99.4	879.8	4.7	8.0	K
BAX-BMX-SMX	180 LB4	30.0	22.0	1775	75.0	37.5	30.0	0.78	93.60	93.00	92.30	118.4	1047.9	4.0	6.9	H
BAX-BMX-SMX	200 LB4	40.0	30.0	1777	94.0	47.0	37.6	0.86	94.10	94.30	93.70	162.0	1433.8	3.4	9.4	K
BAHX-BMX-SMX	225 S4	50.0	37.0	1779	115.6	57.8	46.2	0.85	94.50	94.70	94.00	198.6	1757.8	3.3	9.5	K
BAHX-BMX-SMX	225 M4	60.0	45.0	1779	138.4	69.2	55.4	0.86	95.00	95.20	94.20	241.6	2138.3	3.3	9.5	K
6 pole - 1200 RPM																
BAX-BMX-SMX	90 LA6	1.0	0.75	1140	3.50	1.75	1.40	0.66	82.50	82.20	79.30	6.3	55.8	5.1	8.3	N
BAX-BMX-SMX	100 LA6	1.5	1.1	1160	6.00	3.00	2.40	0.67	87.50	87.70	84.30	9.1	80.5	5.1	8.3	P
BAX-BMX-SMX	112 MB6	2.0	1.5	1170	7.20	3.60	2.90	0.67	88.50	88.70	85.30	12.2	108.0	5.1	8.6	N
BAX-BMX-SMX	132 SB6	3.0	2.2	1172	8.80	4.40	3.52	0.70	89.50	89.70	86.30	17.9	158.4	4.7	8.9	N
BAX-BMX-SMX	132 MA6	4.0	3.0	1172	12.0	6.00	4.80	0.70	89.50	89.70	87.70	24.4	216.0	4.1	8.8	N
BAX-BMX-SMX	132 MB6	5.0	3.7	1172	15.0	7.50	6.00	0.70	89.50	89.70	87.70	30.1	266.4	4.1	8.8	N
BAX-BMX-SMX	160 MA6	7.5	5.5	1175	21.8	10.9	8.70	0.70	91.00	91.10	87.80	44.7	395.6	6.7	13.7	R
BAX-BMX-SMX	160 MB6	10.0	7.5	1175	27.6	13.8	11.0	0.75	91.00	91.10	87.80	61.0	539.9	4.9	10.9	N
BAX-BMX-SMX	160 LA6	12.5	9.2	1177	34.0	17.0	13.6	0.71	91.00	91.10	87.80	74.6	660.3	4.8	11.2	N
BAX-BMX-SMX	160 LB6	15.0	11	1175	39.2	19.6	15.7	0.75	91.70	91.80	88.50	89.4	791.3	4.0	9.7	M
BAX-BMX-SMX	180 LB6	20.0	15	1175	56.0	28.0	22.4	0.73	91.70	91.80	90.20	121.9	1078.9	3.6	8.9	L
BAX-BMX-SMX	200 LA6	25.0	18.5	1181	66.6	33.3	26.6	0.75	93.00	93.20	89.80	149.6	1324.1	4.1	9.0	L
BAX-BMX-SMX	200 LB6	30.0	22	1180	76.2	38.1	30.5	0.78	93.00	93.20	89.80	178.0	1575.4	3.4	7.9	J
BAHX-BMX-SMX	225 M6	40.0	30	1188	101.2	50.6	40.5	0.79	94.10	94.40	94.00	241.2	2134.8	3.6	8.3	K
BAHX-BMX-SMX	250 M6	50.0	37	1188	125.0	62.5	50.0	0.79	94.10	94.40	94.00	297.4	2632.2	3.6	8.3	K

1. Motor characteristic values reported on the tables, refer to operating conditions at a maximum ambient temperature of 40 °C and an altitude up to 1000 m. above sea level. / Les valeurs indiquées sont valables pour une température ambiante maximum de 40 °C et une altitude maximum de 1000m au-dessus du niveau de la mer.
 2. MGM Motori Elettrici S.p.A. has made every effort to make this data complete and accurate. Since products are continu-

ously being improved, all data is subject to change or correction. The data presented here is for general information to provide an overview of MGM capabilities. For specific applications, installation and operating instructions, certified dimensions, capabilities and performance data, and pricing and availability, contact MGM staff. / MGM Motori Elettrici S.p.A. a fait tous les efforts pour rendre ces données complètes et exactes. Les produits

étant continuellement améliorés, toutes les données peuvent être modifiées ou corrigées. Les données présentées ici sont des informations générales et permettent de fournir un aperçu des capacités d'MGM. Pour des applications spécifiques, pour les instructions d'installation et d'utilisation, les dimensions des moteurs, les capacités et les données de performance, ainsi que les prix et la disponibilité, contactez le personnel de MGM.

Motor type	Power		RPM	In (A) 230V 60Hz	In (A) 460V 60Hz	In (A) 575V 60Hz	cos φ	Tn (Nm)	Ts/Tn	Is/In	Eff. 100%	Code
	Hp	kW										
2 pole - 3600 RPM												
BM-SM 56 A2	0.12	0.09	3396	0.74	0.37	0.29	0.56	0.25	3.2	3,7	54.9	L
BM-SM 56 B2	0.16	0.12	3333	0.79	0.39	0.32	0.65	0.34	3.4	3,7	58.8	J
BM-SM 63 A2	0.25	0.18	3394	1.08	0.54	0.43	0.69	0.51	3.3	3,7	60.6	H
BM-SM 63 B2	0.33	0.25	3393	1.45	0.72	0.58	0.73	0.71	3.8	5,0	60.4	K
BM-SM 63 C2	0.50	0.37	3396	1.98	0.99	0.79	0.80	1.04	2.8	3,7	58.3	G
BA-BM-SM 71 A2	0.50	0.37	3516	1.88	0.94	0.75	0.74	0.98	3.0	4,1	65.3	G
BA-BM-SM 71 B2	0.75	0.55	3392	2.68	1.34	1.07	0.80	1.85	2.4	4,5	74.0	H
BA-BM-SM 71 C2	1.00	0.75	3414	3.40	1.70	1.36	0.74	2.10	2.8	4,6	75.8	G
BA-BM-SM 80 A2	1.00	0.75	3388	2.88	1.44	1.15	0.87	2.15	3.4	6,0	75.8	H
BA-BM-SM 80 B2	1.50	1.10	3381	4.04	2.02	1.61	0.88	3.12	3.4	6,0	78.0	H
BA-BM-SM 90 SA2	2.00	1.50	3384	5.66	2.83	2.26	0.86	4.24	3.2	7,5	77.7	K
BA-BM-SM 90 LA2	3.00	2.20	3418	7.98	3.99	3.19	0.88	6.17	3.3	7,5	79.0	J
BA-BM-SM 100 LA2	4.00	3.00	3439	11.8	5.89	4.71	0.83	8.40	2.4	8,2	78.0	L
BA-BM-SM 112 MB2	5.50	4.00	3449	13.0	6.50	5.20	0.87	11.08	2.7	8,8	81.5	K
BA-BM-SM 132 SA2	7.50	5.50	3499	17.9	8.95	7.16	0.89	14.95	3.1	8,6	86.5	K
BA-BM-SM 132 SB2	10.00	7.50	3508	24.1	12.1	9.65	0.87	20.40	3.1	8,6	89.6	K
BA-BM-SM 132 MA2	12.50	9.20	3528	31.8	15.9	12.7	0.84	24.90	3.1	8,0	86.4	K
BA-BM-SM 132 MB2	15.00	11.00	3507	35.2	17.6	14.1	0.91	29.95	3.1	8,6	85.8	K
BA-BM-SM 160 MA2	15.00	11.00	3529	33.5	16.7	13.4	0.92	29.80	3.3	9,8	89.6	K
BA-BM-SM 160 MB2	20.00	15.00	3519	45.3	22.6	18.1	0.92	40.70	3.4	9,8	90.3	K
BA-BM-SM 160 LA2	25.00	18.50	3535	55.5	27.7	22.2	0.92	50.00	3.4	9,8	90.5	K
BA-BM-SM 180 LA2	30.00	22.00	3552	65.2	32.6	26.1	0.93	59.00	3.0	9,7	90.4	K
BA-BM-SM 200 LA2	40.00	30.00	3537	89.9	44.9	35.9	0.92	80.90	3.1	10,0	90.3	K
BA-BM-SM 200 LB2	50.00	37.00	3531	112.8	56.4	45.1	0.92	100.10	3.1	9,8	89.4	K

1. Motor characteristic values reported on the tables, refer to operating conditions at a maximum ambient temperature of 40 °C and an altitude up to 1000 m. above sea level. The rated power indicated on each motor nameplate at 60Hz is 20% higher than described on the above spreadsheet. Also all the nameplates data are referred to the nameplated motor power. Only for BAHX-BMX-SMX 250-280 motors the tables data coincides with the nameplate data. / Les valeurs indiquées sont valables pour une température ambiante maximum de 40 °C et une altitude maximum de 1000m au-dessus du niveau de la mer. Sur la plaque signalétique de chaque moteur, la puissance nominale indiqué pour 60Hz est 20% supérieur à celle décrite dans le document

ci-dessus. Toutes les valeurs indiqués sur la plaque signalétique sont valables à la puissance nominale du moteur. Les valeurs indiqués sur la plaque signalétique coïncident avec les valeurs ci-dessus seulement pour les moteurs BAHX-BMX-SMX 250-280. 2. MGM Motori Elettrici S.p.A. has made every effort to make this data complete and accurate. Since products are continuously being improved, all data is subject to change or correction. The data presented here is for general information to provide an overview of MGM capabilities. For specific applications, installation and operating instructions, certified dimensions, capabilities and performance data, and pricing and availability, contact MGM staff. / MGM Motori Elettrici S.p.A. a fait tous les efforts

pour rendre ces données complètes et exactes. Les produits étant continuellement améliorés, toutes les données peuvent être modifiées ou corrigées. Les données présentées ici sont des informations générales et permettent de fournir un aperçu des capacités d'MGM. Pour des applications spécifiques, pour les instructions d'installation et d'utilisation, les dimensions des moteurs, les capacités et les données de performance, ainsi que les prix et la disponibilité, contactez le personnel de MGM. 3. Efficiency data at 50% and 75% of the full load are available in the specific product documentation. / Pour tous les moteurs, l'efficacité à 50% et 75% de la puissance nominale est disponible sur la fiche technique du produit.

Motor type	Power		RPM	In (A) 230V 60Hz	In (A) 460V 60Hz	In (A) 575V 60Hz	cos φ	Tn (Nm)	Ts/Tn	Is/In	Eff. 100%	Code
	Hp	kW										
4 pole - 1800 RPM												
BM-SM 56 A4	0.08	0.06	1662	0.68	0.34	0.27	0.44	0.33	3.4	2,5	48.3	K
BM-SM 56 B4	0.12	0.09	1660	0.70	0.35	0.42	0.56	0.52	3.4	2,5	56.6	F
BM-SM 63 A4	0.16	0.12	1626	0.86	0.43	0.34	0.65	0.71	2.2	2,4	54.7	F
BM-SM 63 B4	0.25	0.18	1666	1.26	0.63	0.50	0.62	1.03	3.4	2,6	57.6	F
BM-SM 63 C4	0.30	0.22	1644	1.53	0.76	0.61	0.67	1.28	3.1	2,9	53.5	G
BM-SM 63 D4	0.40	0.30	1626	1.75	0.88	0.70	0.71	1.74	3.1	3,4	59.6	G
BA-BM-SM 71 A4	0.33	0.25	1700	1.42	0.71	0.57	0.66	1.41	2.8	4,0	66.8	H
BA-BM-SM 71 B4	0.50	0.37	1680	1.96	0.98	0.78	0.67	2.14	2.9	4,2	71.6	H
BA-BM-SM 71 C4	0.75	0.55	1665	2.72	1.36	1.09	0.71	3.17	2.7	4,3	72.4	G
BA-BM-SM 80 A4	0.75	0.55	1699	2.76	1.38	1.10	0.68	3.07	2.3	4,7	73.0	H
BA-BM-SM 80 B4	1.00	0.75	1700	3.74	1.87	1.50	0.68	4.18	2.8	4,8	73.7	H
BA-BM-SM 80 C4	1.20	0.90	1692	4.56	2.28	1.82	0.66	5.1	3.1	4,9	75.6	J
BA-BM-SM 90 SA4	1.50	1.10	1671	4.86	2.43	1.94	0.81	6.84	2.3	4,9	76.2	H
BA-BM-SM 90 LA4	2.00	1.50	1704	6.10	3.05	2.44	0.78	8.45	3.0	5,4	80.0	G
BA-BM-SM 90 LB4	2.50	1.85	1668	7.80	3.90	3.12	0.78	10.56	2.9	6,1	76.1	H
BA-BM-SM 90 LC4	3.00	2.20	1680	9.38	4.69	3.75	0.74	12.6	2.9	5,5	80.1	H
BA-BM-SM 100 LA4	3.00	2.20	1713	8.50	4.25	3.40	0.80	12.35	2.7	6,1	81.7	H
BA-BM-SM 100 LB4	4.00	3.00	1712	11.4	5.72	4.57	0.81	16.8	3.1	7,0	81.2	J
BA-BM-SM 112 MB4	5.50	4.00	1714	14.6	7.31	5.85	0.82	22.4	2.9	6,8	83.7	J
BA-BM-SM 112 MBX4	6.70	5.00	1735	19.2	9.60	7.7	0.75	27.2	3.5	8,0	82.7	L
BA-BM-SM 132 SB4	7.50	5.50	1731	19.7	9.86	7.89	0.84	30.4	2.6	6,6	83.5	H
BA-BM-SM 132 MA4	10.00	7.50	1718	26.4	13.2	10.6	0.85	41.8	2.6	6,4	84.0	H
BA-BM-SM 132 MB4	12.50	9.20	1728	31.5	15.8	12.6	0.85	50.9	2.7	7,0	86.2	H
BA-BM-SM 160 MA4	12.50	9.20	1768	32.7	16.3	13.1	0.82	49.9	3.3	7,6	86.7	J
BA-BM-SM 160 MB4	15.00	11.00	1752	38.2	19.1	15.3	0.82	59.9	3.2	7,4	87.6	J
BA-BM-SM 160 LA4	20.00	15.00	1760	50.2	25.1	20.1	0.83	81.4	3.0	7,6	90.0	J
BA-BM-SM 180 LA4	25.00	18.50	1761	59.7	29.9	23.9	0.85	100.2	3.2	8,7	91.7	K
BA-BM-SM 180 LB4	30.00	22.00	1762	73.1	36.5	29.2	0.83	119.2	2.8	8,3	91.2	K
BA-BM-SM 200 LB4	40.00	30.00	1752	97.5	48.8	39.0	0.85	163.5	2.7	8,2	91.2	J
BA-BM-SM 225 S4	50.00	37.00	1775	119.7	59.8	47.9	0.84	199.2	2.7	8,6	92.8	K
BA-BM-SM 225 M4	60.00	45.00	1783	146.0	73.1	58.5	0.83	241.1	2.8	8,6	93.8	K
BAHX-BMX-SMX 250 M4	75.00	55.00	1785	176.8	88.4	70.7	0.82	294	3.5	10,3	94.0	L
BAHX-BMX-SMX 280 S4	100.00	75.00	1785	243.6	121.8	97.4	0.81	401	2.6	8,6	95.1	K
BAHX-BMX-SMX 280 M4	125.00	90.00	1786	293.8	146.9	117.5	0.81	481	2.8	10,1	95.0	L

1. Motor characteristic values reported on the tables, refer to operating conditions at a maximum ambient temperature of 40 °C and an altitude up to 1000 m. above sea level. The rated power indicated on each motor nameplate at 60Hz is 20% higher than described on the above spreadsheet. Also all the nameplates data are referred to the nameplated motor power. Only for BAHX-BMX-SMX 250-280 motors the tables data coincides with the nameplate data. / Les valeurs indiquées sont valables pour une température ambiante maximum de 40 °C et une altitude maximum de 1000m au-dessus du niveau de la mer. Sur la plaque signalétique de chaque moteur, la puissance nominale indiquée pour 60Hz est 20% supérieure à celle décrite dans le document

ci-dessus. Toutes les valeurs indiquées sur la plaque signalétique sont valables à la puissance nominale du moteur. Les valeurs indiquées sur la plaque signalétique coïncident avec les valeurs ci-dessus seulement pour les moteurs BAHX-BMX-SMX 250-280. 2. MGM Motori Elettrici S.p.A. has made every effort to make this data complete and accurate. Since products are continuously being improved, all data is subject to change or correction. The data presented here is for general information to provide an overview of MGM capabilities. For specific applications, installation and operating instructions, certified dimensions, capabilities and performance data, and pricing and availability, contact MGM staff. / MGM Motori Elettrici S.p.A. a fait tous les efforts

pour rendre ces données complètes et exactes. Les produits étant continuellement améliorés, toutes les données peuvent être modifiées ou corrigées. Les données présentées ici sont des informations générales et permettent de fournir un aperçu des capacités d'MGM. Pour des applications spécifiques, pour les instructions d'installation et d'utilisation, les dimensions des moteurs, les capacités et les données de performance, ainsi que les prix et la disponibilité, contactez le personnel de MGM. 3. Efficiency data at 50% and 75% of the full load are available in the specific product documentation. / Pour tous les moteurs, l'efficacité à 50% et 75% de la puissance nominale est disponible sur la fiche technique du produit.

Motor type	Power		RPM	In (A) 230V 60Hz	In (A) 460V 60Hz	In (A) 575V 60Hz	cos φ	Tn (Nm)	Ts/Tn	Is/In	Eff. 100%	Code
	Hp	kW										
6 pole - 1200 RPM												
BM-SM 56 B6	0.08	0.06	1008	0.90	0.45	0.36	0.70	0.57	2.0	1,4	24.1	H
BM-SM 63 C6	0.12	0.09	1050	1.08	0.54	0.43	0.54	0.82	2.6	1,7	38.6	G
BM-SM 63 D6	0.16	0.12	994	1.30	0.65	0.52	0.57	1.17	2.8	1,7	41.2	F
BA-BM-SM 71 A6	0.25	0.18	1093	1.11	0.56	0.45	0.69	1.62	2.2	2,7	60.1	E
BA-BM-SM 71 B6	0.33	0.25	1094	1.46	0.73	0.59	0.71	2.22	2.2	2,9	61.6	F
BA-BM-SM 80 A6	0.50	0.37	1123	2.26	1.13	0.90	0.62	3.13	2.9	3,6	65.8	H
BA-BM-SM 80 B6	0.75	0.55	1110	3.10	1.55	1.24	0.66	4.77	2.4	3,1	67.6	F
BA-BM-SM 90 SA6	1.00	0.75	1099	3.68	1.84	1.47	0.71	6.45	2.3	4,2	71.3	G
BA-BM-SM 90 LA6	1.50	1.10	1088	5.38	2.69	2.15	0.72	9.77	2.4	4,1	71.9	G
BA-BM-SM 90 LB6	1.75	1.30	1104	6.58	3.29	2.63	0.67	11.35	2.7	4,5	74.7	H
BA-BM-SM 100 LA6	2.0	1.50	1133	6.49	3.25	2.60	0.73	12.62	2.6	5,0	80.0	G
BA-BM-SM 100 LB6	2.5	1.85	1134	9.02	4.51	3.61	0.64	15.57	2.9	4,8	80.0	H
BA-BM-SM 112 MB6	3.0	2.20	1147	9.46	4.73	3.78	0.74	18.40	2.2	5,6	79.4	H
BA-BM-SM 132 SB6	4.0	3.00	1165	11.7	5.85	4.68	0.72	24.66	2.8	7,7	89.7	K
BA-BM-SM 132 MA6	5.5	4.00	1159	16.0	8.0	6.40	0.73	32.90	2.5	7,4	85.8	K
BA-BM-SM 132 MB6	7.5	5.50	1158	21.7	10.9	8.69	0.72	45.60	2.5	7,0	88.7	K
BA-BM-SM 160 MB6	10.0	7.50	1165	29.6	14.8	11.9	0.74	61.50	2.4	7,3	85.9	K
BA-BM-SM 160 LA6	12.5	9.20	1167	33.1	16.5	13.2	0.78	75.40	2.4	7,5	89.7	J
BA-BM-SM 160 LB6	15.0	11.00	1166	42.9	21.4	17.1	0.73	90.40	2.7	7,6	88.5	K
BA-BM-SM 180 LB6	20.0	15.00	1176	53.8	26.9	21.5	0.76	121.90	2.5	8,2	91.6	K
BA-BM-SM 200 LA6	25.0	18.50	1169	68.9	34.5	27.6	0.75	151.40	2.4	8,5	90.0	L
BA-BM-SM 200 LB6	30.0	22.00	1164	78.8	39.4	31.5	0.78	181.00	2.4	8,5	90.1	K
BA-BM-SM 225 M6	40.0	30.00	1181	96.2	48.1	38.5	0.84	240.10	2.9	9,7	92.4	K
BAHX-BMX-SMX 250 M6	50.0	37.00	1188	125.0	62.5	50.0	0.79	297.4	3.5	8,3	93.0	K
BAHX-BMX-SMX 280 S6	60.0	45.00	1193	151.2	75.6	60.5	0.80	361.00	3.5	7,9	93.6	K
BAHX-BMX-SMX 280 M6	75.0	55.00	1193	184.0	92.0	73.6	0.80	442.00	3.5	7,5	94.2	J

1. Motor characteristic values reported on the tables, refer to operating conditions at a maximum ambient temperature of 40 °C and an altitude up to 1000 m. above sea level. The rated power indicated on each motor nameplate at 60Hz is 20% higher than described on the above spreadsheet. Also all the nameplates data are referred to the nameplated motor power. Only for BAHX-BMX-SMX 250-280 motors the tables data coincides with the nameplate data. / Les valeurs indiquées sont valables pour une température ambiante maximum de 40 °C et une altitude maximum de 1000m au-dessus du niveau de la mer. Sur la plaque signalétique de chaque moteur, la puissance nominale indiqué pour 60Hz est 20% supérieur à celle décrite dans le document

ci-dessus. Toutes les valeurs indiqués sur la plaque signalétique sont valables à la puissance nominale du moteur. Les valeurs indiqués sur la plaque signalétique coïncident avec les valeurs ci-dessus seulement pour les moteurs BAHX-BMX-SMX 250-280. 2. MGM Motori Elettrici S.p.A. has made every effort to make this data complete and accurate. Since products are continuously being improved, all data is subject to change or correction. The data presented here is for general information to provide an overview of MGM capabilities. For specific applications, installation and operating instructions, certified dimensions, capabilities and performance data, and pricing and availability, contact MGM staff. / MGM Motori Elettrici S.p.A. a fait tous les efforts

pour rendre ces données complètes et exactes. Les produits étant continuellement améliorés, toutes les données peuvent être modifiées ou corrigées. Les données présentées ici sont des informations générales et permettent de fournir un aperçu des capacités d'MGM. Pour des applications spécifiques, pour les instructions d'installation et d'utilisation, les dimensions des moteurs, les capacités et les données de performance, ainsi que les prix et la disponibilité, contactez le personnel de MGM. 3. Efficiency data at 50% and 75% of the full load are available in the specific product documentation. / Pour tous les moteurs, l'efficacité à 50% et 75% de la puissance nominale est disponible sur la fiche technique du produit.

Manual brake release and shaft rotation

A manual brake release might be needed to perform maintenance on a machine where a motor is installed; As well as to manually operate a machine in case of a power supply failure.

BA Series motors are equipped with a central screw to manually release the brake (for the BAH Series motors there are 2 side screws). This is a "locking" type brake release so that the brake stays disengaged until the screw is tightened on the brake assembly. Upon request the brake can be provided with a non-locking mechanism (fulcrum style).

On BM Series motors, we can provide an optional hand release lever (non-locking type) to manually release the brake. The lever is mounted on the same side as the terminal box, unless otherwise requested.

BA and BM Series motors up to frame size 132mm (NEMA 245) come equipped with a hex socket on the non-drive end to manually rotate the shaft with a hex wrench once the brake is disengaged. This standard feature (MGM patent) is very useful for applications requiring manual positioning or a machine reset. Most of the time this feature prevents the need for a special double shaft extension for manual rotation. Upon request it's also possible to have motors equipped with this hex socket on frame sizes 160 and over (IEC 160 to 315).

Safety warning: When the brake is manually released the motor shaft is no longer engaged by the brake, therefore the shaft is free to rotate. For this reason the manual brake release must be operated only when there are no safety concerns for any applied or suspended load. The brake must always be properly re-engaged once manual intervention is completed. Motors shall never be started with any tool inserted into a motors hex socket; such tools must be properly removed after any manual intervention. Failure to heed these warnings could lead to serious injury and / or damage.

Débloccage manuel du frein et rotation de l'arbre

Le débloccage manuel du frein est nécessaire pour effectuer des opérations de maintenance sur la machine sur laquelle le moteur est installé ou quand il est nécessaire de libérer le frein en l'absence d'alimentation électrique.

Les moteurs de la série BA sont fournis de série avec une vis de débloccage manuel du frein (deux vis latérales pour la série BAH). Avec cette vis, le débloccage du frein est "verrouillé", c'est à dire que le frein reste ouvert tant que la vis reste vissée sur le moteur. Sur demande, un système de débloccage "non verrouillé", avec retour automatique, est disponible.

Pour les moteurs de la série BM, le levier de déverrouillage manuel du frein est disponible sur demande et est de type "non verrouillé" avec retour automatique. Habituellement, l'orientation du levier de débloccage est la même que celle du boîtier de borne. Différentes orientations sont disponibles sur demande.

Pour les moteurs qui ont une hauteur d'arbre jusqu'à 132 mm (BA et BM), les moteurs viennent de série avec un trou hexagonal à l'intérieur de l'arbre. Une fois que le frein est débloqué, une clé hexagonale peut être insérée pour pivoter manuellement l'arbre du moteur. Ce système, conçu par MGM, est donc très utile lorsque le moteur est déjà installé sur la machine et que vous devez faire pivoter manuellement le moteur pour des réglages. Ce système est très apprécié car il permet d'utiliser un moteur standard avec un seul arbre de sortie dans ces cas-là, rendant inutile l'option d'un second arbre. Sur demande, le trou hexagonal dans l'arbre est disponible pour les moteurs avec une hauteur d'arbre de 160mm à 315mm.

Avertissement de sécurité: lorsque le mécanisme de débloccage du frein est activé, la rotation de l'arbre du moteur est libre et aucun freinage n'est appliqué dessus. Le débloccage manuel doit être activé seulement après avoir préalablement vérifié que cela ne comporte aucun problème de sécurité pour toutes les charges appliquées et en suspension. Le mécanisme de débloccage doit être déconnecté à la fin de tous les travaux de maintenance. La clé hexagonale ne doit jamais être laissée insérée sur le moteur, mais retirée après chaque utilisation et vous devez vérifier que la machine ne peut pas être démarrée avec la clé insérée. Le non-respect de ces avertissements peut entraîner de graves blessures sur des personnes et/ou des biens.

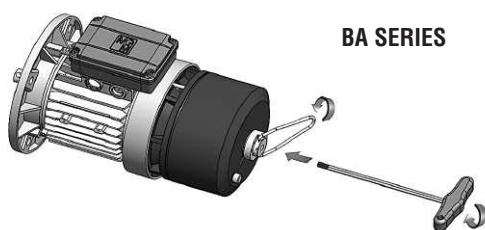

BA SERIES

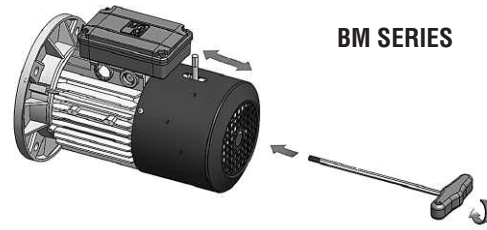

BM SERIES

Brake torque and reaction time / Couple de freinage et temps de réaction

Frame Size - Hauteur d'axe				56	63	71	80	90	100	112	132	160	180	200	225	250	280
Maximum brake torque Couple de freinage maximum	BAX-BA	AC Brake - Frein AC	Nm Lb-in.	-	-	14 124	18 159	38 337	50 443	80 708	150 1328	190 1683	300 2657	300 2657	600 5310	700 6198	1000 8857
	BAX-BA	DC Brake - Frein DC	Nm Lb-in.	-	-	9 80	15 133	30 266	42 372	60 531	120 1063	155 1373	180 1594	180 1594	600 5310	-	-
	BMX-BM	DC Brake - Frein DC	Nm Lb-in.	2 17	5 44	5 44	10 88	20 177	40 354	60 531	100 885	150 1328	250 2212	250 2212	400 3540	-	-
Brake electrical reaction time Temps de réaction électrique du frein	BAX-BA	AC Brake - Frein AC	ms	-	-	7	7	7	9	9	12	12	12	12	14	14	14
	BAX-BA	DC Brake ¹ - Frein DC ¹	ms	-	-	80	80	80	80	80	85	85	90	90	100	-	-
	BAX-BA	DC Brake ² - Frein DC ²	ms	-	-	20	20	20	30	30	30	30	30	30	35	-	-
	BMX-BM	DC Brake ¹ - Frein DC ¹	ms	60	90	90	145	180	225	290	420	570	600	600	900	-	-
	BMX-BM	DC Brake ² - Frein DC ²	ms	25	35	35	50	60	75	90	120	150	180	180	200	-	-

(¹) standard - (²) quick / rapide

	56	63	71	80	90S	90L	100L	112M	132S	132M	160M	160L	180	200	225S	225M
A	90 3.54	100 3.94	112 4.41	125 4.92	140 5.51	140 5.51	160 6.30	190 7.48	216 8.50	216 8.50	254 10.00	254 10.00	279 10.98	318 12.52	356 14.02	356 14.02
B	71 2.80	80 3.15	90 3.54	100 3.94	100 3.94	125 4.92	140 5.51	140 5.51	140 5.51	178 7.01	210 8.27	254 10.00	279 10.98	305 12.01	286 11.26	311 12.24
C	36 1.42	40 1.57	45 1.77	50 1.97	56 2.20	56 2.20	63 2.48	70 2.76	89 3.50	89 3.50	108 4.25	108 4.25	121 4.76	133 5.24	149 5.87	149 5.87
D	9 0.35	11 0.43	14 0.55	19 0.75	24 0.95	24 0.95	28 1.10	28 1.10	38 1.50	38 1.50	42 1.65	42 1.65	48 1.89	55 2.17	60 2.36	60 2.36
d	M3	M4	M5	M6	M8	M8	M10	M10	M12	M12	M16	M16	M16	M20	M20	M20
E	20 0.79	23 0.91	30 1.18	40 1.57	50 1.97	50 1.97	60 2.36	60 2.36	80 3.15	80 3.15	110 4.33	110 4.33	110 4.33	110 4.33	140 5.51	140 5.51
Fa	6.6 0.26	9.5 0.37	9.5 0.37	11.5 0.45	11.5 0.45	11.5 0.45	14.5 0.57	14.5 0.57	14.5 0.57	14.5 0.57	18.5 0.73	18.5 0.73	18.5 0.73	18.5 0.73	18.5 0.73	18.5 0.73
Fb	M5	M5	M6	M6	M8	M8	M8	M8	M10	M10	-	-	-	-	-	-
f	3 0.12	4 0.16	5 0.20	6 0.24	8 0.31	8 0.31	8 0.31	8 0.31	10 0.39	10 0.39	12 0.47	12 0.47	14 0.55	16 0.63	18 0.71	18 0.71
g	7.2 0.28	8.5 0.33	11 0.43	15.5 0.61	20 0.79	20 0.79	24 0.94	24 0.94	33 1.30	33 1.30	37 1.46	37 1.46	42.5 1.67	49 1.93	53 2.09	53 2.09
H	56 2.20	63 2.48	71 2.80	80 3.15	90 3.54	90 3.54	100 3.94	112 4.41	132 5.20	132 5.20	160 6.30	160 6.30	180 7.09	200 7.87	225 8.86	225 8.86
h	3 0.12	4 0.16	5 0.20	6 0.24	7 0.28	7 0.28	8 0.31	8 0.31	8 0.31	8 0.31	8 0.31	8 0.31	9 0.35	10 0.39	11 0.43	11 0.43
I	6 0.24	7 0.28	7 0.28	10 0.39	10 0.39	10 0.39	12 0.47	12 0.47	12 0.47	12 0.47	14.5 0.57	14.5 0.57	14.5 0.57	18.5 0.73	18 0.71	18 0.71
K	11 0.43	10.5 0.41	10.5 0.41	14 0.55	14 0.55	14 0.55	16 0.63	16 0.63	22 0.87	22 0.87	24 0.94	24 0.94	24 0.94	30 1.18	18 0.71	18 0.71
L	99 3.90	130 5.12	145 5.71	162 6.38	171 6.73	196 7.72	217 8.54	229 9.02	255 10.04	293 11.54	-	-	-	-	-	-
L1	166 6.54	182 7.16	194 7.64	207 8.15	232 9.13	254 10.00	262 10.31	294 11.57	339 13.35	373 14.69	395 15.55	420.5 16.56	445.5 17.54	440 17.32	440 17.32	440 17.32
Ma	100 3.94	115 4.53	130 5.12	165 6.50	165 6.50	165 6.50	215 8.46	215 8.46	265 10.43	265 10.43	300 11.81	300 11.81	300 11.81	350 13.78	400 15.75	400 15.75
Mb	65 2.56	75 2.95	85 3.35	100 3.94	115 4.53	115 4.53	130 5.12	130 5.12	165 6.50	165 6.50	-	-	-	-	-	-
Na	80 3.15	95 3.74	110 4.33	130 5.12	130 5.12	130 5.12	180 7.09	180 7.09	230 9.06	230 9.06	250 9.84	250 9.84	250 9.84	300 11.81	350 13.78	350 13.78
Nb	50 1.97	60 2.36	70 2.76	80 3.15	95 3.74	95 3.74	110 4.33	110 4.33	130 5.12	130 5.12	-	-	-	-	-	-
Oa	3 0.12	3 0.12	3.5 0.14	3.5 0.14	3.5 0.14	3.5 0.14	4 0.16	4 0.16	4 0.16	4 0.16	5 0.20	5 0.20	5 0.20	5 0.20	5 0.20	5 0.20
Ob	2.5 0.10	2.5 0.10	2.5 0.10	3 0.12	3 0.12	3 0.12	3.5 0.14	3.5 0.14	3.5 0.14	3.5 0.14	-	-	-	-	-	-
Pa	120 4.72	140 5.51	160 6.30	200 7.87	200 7.87	200 7.87	250 9.84	250 9.84	300 11.81	300 11.81	350 13.78	350 13.78	350 13.78	400 15.75	450 17.72	450 17.72
Pb	80 3.15	90 3.54	105 4.13	120 4.72	140 5.51	140 5.51	160 6.30	160 6.30	200 7.87	200 7.87	-	-	-	-	-	-
Q	230 9.06	260 10.24	295 11.61	334 13.15	360 14.17	385 15.16	435 17.13	470 18.50	565 22.24	604 23.78	716 27.17	760 28.90	863 33.98	888 34.96	961 37.83	961 37.83
R	75 2.95	80 3.15	80 3.15	80 3.15	98.5 3.88	98.5 3.88	98.5 3.88	98.5 3.88	108 4.25	108 4.25	-	-	-	-	-	-
R1	135 5.31	135 5.31	135 5.31	170 6.69	170 6.69	170 6.69	170 6.69	199 7.83	199 7.83	268 10.55	268 10.55	268 10.55	268 10.55	327 12.87	327 12.87	327 12.87
S	8 0.31	10 0.39	10 0.39	12 0.47	12 0.47	12 0.47	14 0.55	14 0.55	15 0.59	15 0.59	15 0.59	15 0.59	15 0.59	19.5 0.77	15 0.59	20 0.79
V	7 0.28	7 0.28	8 0.31	9.5 0.37	10.5 0.41	10.5 0.41	12.5 0.49	13.5 0.53	16 0.63	16 0.63	21 0.83	21 0.83	24 0.94	24 0.94	32 1.26	32 1.26
W	93 3.66	97 3.82	105 4.13	113 4.45	127 5.00	127 5.00	138 5.43	158 6.22	198 7.80	198 7.80	155 6.10	155 6.10	179 7.05	179 7.05	224 8.82	224 8.82
W1	111 4.37	121 4.76	130 5.12	148 5.83	148 5.83	162 6.38	176 6.93	258 10.16	258 10.16	309.5 12.19	309.5 12.19	269.5 10.61	269.5 10.61	337 13.27	337 13.27	337 13.27
Y	110 4.33	121 4.76	136 5.35	153 6.02	178 7.01	178 7.01	198 7.80	219.5 8.64	255 10.04	255 10.04	293 11.54	293 11.54	355 13.98	355 13.98	433 17.05	433 17.05
Z	75 2.95	75 2.95	75 2.95	75 2.95	98.5 3.88	98.5 3.88	98.5 3.88	98.5 3.88	108 4.25	108 4.25	-	-	-	-	-	-
Z1	86 3.39	86 3.39	86 3.39	112 4.41	112 4.41	112 4.41	112 4.41	151 5.94	151 5.94	167 6.57	167 6.57	167 6.57	167 6.57	202 7.95	202 7.95	202 7.95

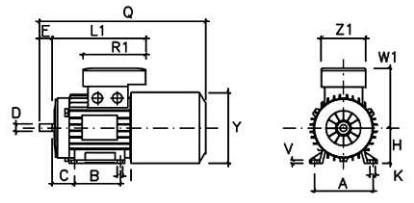
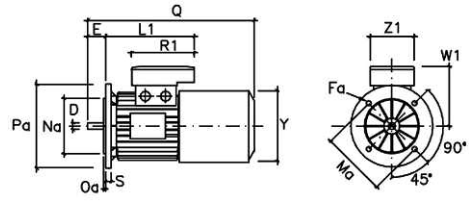
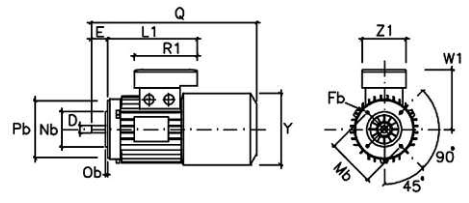
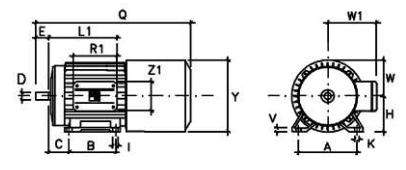
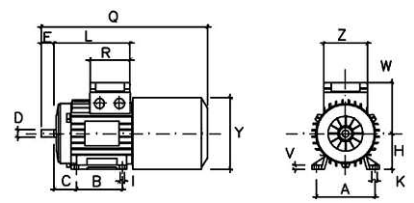
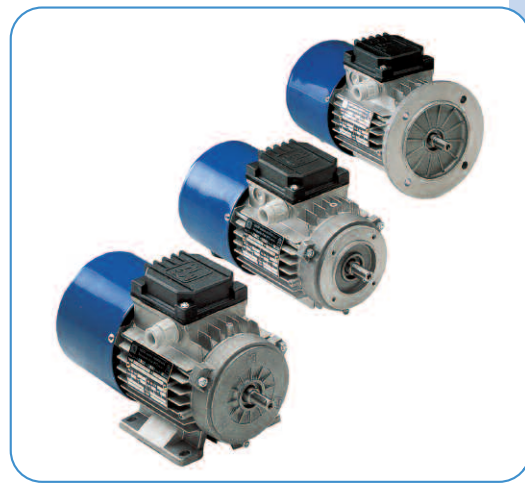
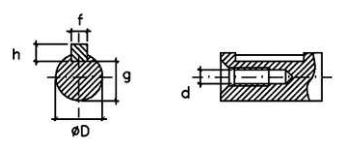
BM B3

BM B5

BM B14

BM 160 B3

Single terminal board box - Boîte avec plaque à bornes simple

Shaft End - Bout d'arbre

Cable glands are M16 on size 56 and 63, M20 on size 71 and 80, M 25 on size 90 up to 112, M 32 on size 132, PG 29 on size 160 up to 200, M50 on size 225 / Le presse étoupe a la dimension M16 pour une hauteur d'axe de 56 et 63 mm, M20 pour une hauteur d'axe de 71 et 80 mm, M25 pour une hauteur d'axe de 90 à 112 mm, M32 pour une hauteur d'axe de 132 mm, PG29 pour une hauteur d'axe de 160 à 200 mm, M50 pour une hauteur d'axe de 225 mm

56 63 71 80 90S 90L 100L 112M 132S 132M 160M 160L 180L 200L 225S 225M

A	90 3.54	100 3.94	112 4.41	125 4.92	140 5.51	140 5.51	160 6.30	190 7.48	216 8.50	216 8.50	254 10.00	254 10.00	279 10.98	318 12.52	356 14.02	356 14.02
B	71 2.80	80 3.15	90 3.54	100 3.94	100 3.94	125 4.92	140 5.51	140 5.51	178 7.01	210 8.27	254 10.00	279 10.98	305 12.01	286 11.26	311 12.24	
C	36 1.42	40 1.57	45 1.77	50 1.97	56 2.20	56 2.20	63 2.48	70 2.76	89 3.50	89 3.50	108 4.25	108 4.25	121 4.76	133 5.24	149 5.87	149 5.87
D*	9 0.35	11 0.43	14 0.55	19 0.75	24 0.95	24 0.95	28 1.10	28 1.10	38 1.50	38 1.50	42 1.65	42 1.65	48 1.89	55 2.17	60 2.36	60 2.36
d	M3	M4	M5	M6	M8	M8	M10	M10	M12	M12	M16	M16	M16	M16	M16	M16
E*	20 0.79	23 0.91	30 1.18	40 1.57	50 1.97	50 1.97	60 2.36	60 2.36	80 3.15	80 3.15	110 4.33	110 4.33	110 4.33	110 4.33	140 5.51	140 5.51
Fa	6.6 0.26	9.5 0.37	9.5 0.37	11.5 0.45	11.5 0.45	11.5 0.45	14.5 0.57	14.5 0.57	14.5 0.57	14.5 0.57	18.5 0.73	18.5 0.73	18.5 0.73	18.5 0.73	18.5 0.73	18.5 0.73
Fb	M5	M5	M6	M6	M8	M8	M8	M8	M10	M10						
f	3 0.12	4 0.16	5 0.20	6 0.24	8 0.31	8 0.31	8 0.31	8 0.31	10 0.39	10 0.39	12 0.47	12 0.47	14 0.55	16 0.63	18 0.71	18 0.71
g	7.2 0.28	8.5 0.33	11 0.43	15.5 0.61	20 0.79	20 0.79	24 0.94	24 0.94	33 1.30	33 1.30	37 1.46	37 1.46	42.5 1.67	49 1.93	53 2.09	53 2.09
H	56 2.20	63 2.48	71 2.80	80 3.15	90 3.54	90 3.54	100 3.94	112 4.41	132 5.20	132 5.20	160 6.30	160 6.30	180 7.09	200 7.87	225 8.86	225 8.86
h	3 0.12	4 0.16	5 0.20	6 0.24	7 0.28	7 0.28	7 0.28	7 0.28	8 0.31	8 0.31	8 0.31	8 0.31	9 0.35	10 0.39	11 0.43	11 0.43
I	6 0.24	7 0.28	7 0.28	10 0.39	10 0.39	10 0.39	12 0.47	12 0.47	12 0.47	12 0.47	14.5 0.57	15 0.59	15 0.59	18.5 0.73	18 0.71	18 0.71
K	11 0.43	10.5 0.41	10.5 0.41	14 0.55	14 0.55	14 0.55	16 0.63	16 0.63	22 0.87	22 0.87	24 0.94	24 0.94	24 0.94	30 1.18	33 1.30	33 1.30
L	99 3.90	111 4.37	117 4.61	123 4.84	140 5.51	140 5.51	152 5.98	153 6.02	171 6.73	171 6.73						
L1	167 6.57	145 5.71	150 5.91	177 6.97	177 6.97	188 7.40	190 7.48	190 7.48	300 11.81	300 11.81	373 14.69	395 15.55	420 16.54	446 17.56	452 17.80	464.5 18.29
Ma	100 3.94	115 4.53	130 5.12	165 6.50	165 6.50	165 6.50	215 8.46	215 8.46	265 10.43	265 10.43	300 11.81	300 11.81	300 11.81	350 13.78	400 15.75	400 15.75
Mb	65 2.56	75 2.95	85 3.35	100 3.94	115 4.53	115 4.53	130 5.12	130 5.12	165 6.50	165 6.50						
Na	80 3.15	95 3.74	110 4.33	130 5.12	130 5.12	130 5.12	180 7.09	180 7.09	230 9.06	230 9.06	250 9.84	250 9.84	250 9.84	300 11.81	350 13.78	350 13.78
Nb	50 1.97	60 2.36	70 2.76	80 3.15	95 3.74	95 3.74	110 4.33	110 4.33	130 5.12	130 5.12						
Oa	3 0.12	3 0.12	3.5 0.14	3.5 0.14	3.5 0.14	3.5 0.14	4 0.16	4 0.16	4 0.16	4 0.16	5 0.20	5 0.20	5 0.20	5 0.20	5 0.20	5 0.20
Ob	2.5 0.10	2.5 0.10	2.5 0.10	3 0.12	3 0.12	3 0.12	3.5 0.14	3.5 0.14	3.5 0.14	3.5 0.14						
Pa	120 4.72	140 5.51	160 6.30	200 7.87	200 7.87	200 7.87	250 9.84	250 9.84	300 11.81	300 11.81	350 13.78	350 13.78	350 13.78	400 15.75	450 17.72	450 17.72
Pb	80 3.15	90 3.54	105 4.13	120 4.72	140 5.51	140 5.51	160 6.30	160 6.30	200 7.87	200 7.87						
Q	193 7.60	223 8.78	253 9.96	202 7.95	305 12.01	330 12.99	373 14.69	468 18.43	506 19.92	602 23.70	646 25.43	706 27.80	731 28.78	808 31.81	833 32.80	
R	75 2.95	80 3.15	80 3.15	80 3.15	98.5 3.88	98.5 3.88	98.5 3.88	98.5 3.88	108 4.25	108 4.25						
R1	135 5.31	135 5.31	135 5.31	170 6.69	170 6.69	170 6.69	170 6.69	199 7.83	199 7.83	268 10.55	268 10.55	268 10.55	268 10.55	268 10.55	268 10.55	268 10.55
S	6 0.24	10 0.39	10 0.39	12 0.47	12 0.47	12 0.47	14 0.55	14 0.55	15 0.59	15 0.59	15 0.59	15 0.59	15 0.59	15 0.59	16 0.63	16 0.63
V	7 0.28	7 0.28	8 0.31	9.5 0.37	10.5 0.41	10.5 0.41	12.5 0.49	13.5 0.53	16 0.63	16 0.63	21 0.83	21 0.83	24 0.94	24 0.94	30 1.18	30 1.18
W	93 3.66	97 3.82	105 4.13	113 4.45	127 5.00	127 5.00	138 5.43	158 6.22	198 7.80	198 7.80	158 6.22	158 6.22	188 7.40	188 7.40	218 8.58	218 8.58
W1	111 4.37	121 4.76	131 5.16	148 5.83	148 5.83	162 6.38	176 6.93	210 8.27	210 8.27	246 9.69	246 9.69	266 10.47	266 10.47	322 12.68	322 12.68	
Y	110 4.33	120 4.72	138 5.43	155 6.10	174 6.85	174 6.85	192 7.56	217 8.54	260 10.24	260 10.24	315 12.40	315 12.40	355 13.98	355 13.98	430 16.93	430 16.93
Z	75 2.95	75 2.95	75 2.95	75 2.95	98.5 3.88	98.5 3.88	98.5 3.88	98.5 3.88	108 4.25	108 4.25						
Z1	86 3.39	86 3.39	86 3.39	112 4.41	112 4.41	112 4.41	112 4.41	151 5.94	151 5.94	167 6.57	167 6.57	167 6.57	167 6.57	167 6.57	167 6.57	167 6.57

SMX-SM

B3

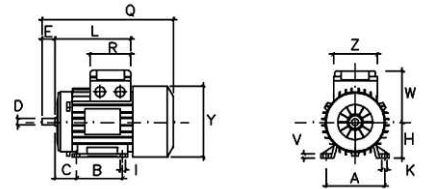

SMX-SM

B5

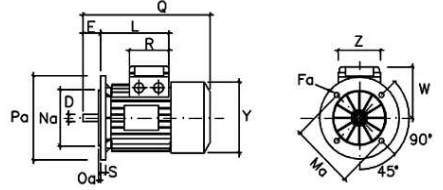

SMX-SM

B14

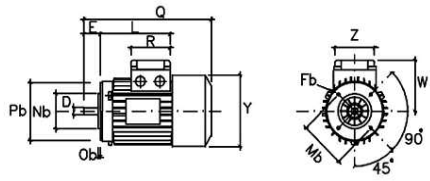

SMX-SM 160÷225

B3

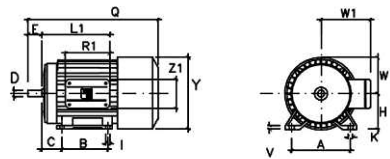

Double terminal board box - Boîte avec plaque à bornes double

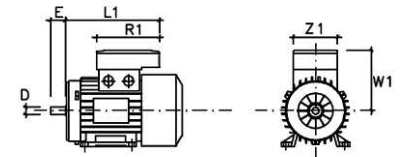

Shaft End - Bout d'arbre

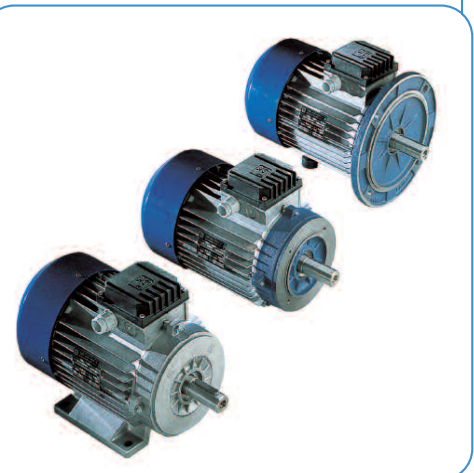
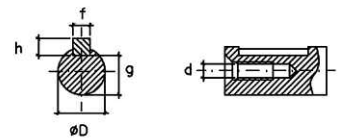

* 225S-225M 2 pole D=55mm (2.17 inch), E=110mm (4.33 inch)

BA-BAX

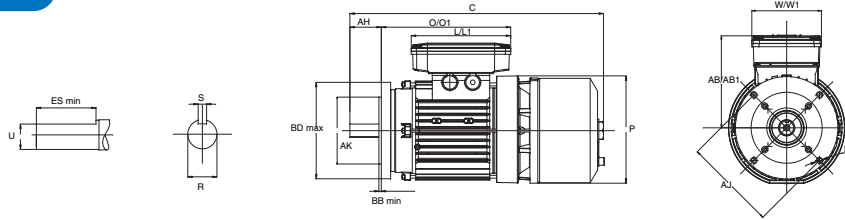

IEC frame size	NEMA flange size	Shaft					Overall dimension						C-Face				
		AH	ES min	U	R	S	C	P	L1	O1	AB1	W1	BB min	AK	AJ	BF	BD max
71	56C	2.06	1.41	0.6250	0.517	0.188	15.093	5.709	5.315	7.756	4.764	3.386	0.16	4.500	5.875	4x3/8-16	6.50
80	56C	2.06	1.41	0.6250	0.517	0.188	16.063	6.299	5.315	8.386	5.118	3.386	0.16	4.500	5.875	4x3/8-16	6.50
90 S	145TC-143TC	2.12	1.41	0.8750	0.771	0.188	17.047	7.087	6.693	8.583	5.827	4.409	0.16	4.500	5.875	4x3/8-16	6.50
90 L	145TC-143TC	2.12	1.41	0.8750	0.771	0.188	18.031	7.087	6.693	9.567	5.827	4.409	0.16	4.500	5.875	4x3/8-16	6.50
100	182TC-184TC	2.62	1.78	1.1250	0.986	0.250	20.118	7.717	6.693	10.295	6.378	4.409	0.25	8.500	7.250	4x1/2-13	9.00
112	182TC-184TC	2.62	1.78	1.1250	0.986	0.250	20.827	8.583	6.693	10.787	6.929	4.409	0.25	8.500	7.250	4x1/2-13	9.00
132 S	213TC-215TC	3.12	2.41	1.3750	1.201	0.312	23.780	10.433	7.835	10.242	8.268	5.945	0.25	8.500	7.250	4x1/2-13	9.00
132 M	213TC-215TC	3.12	2.41	1.3750	1.201	0.312	25.276	10.433	7.835	11.738	8.268	5.945	0.25	8.500	7.250	4x1/2-13	9.00
160 M	254TC-256TC	3.75	2.91	1.625	1.416	0.375	29.331	12.756	10.551	12.900	9.685	6.575	0.25	8.500	7.250	4x1/2-13	9.724
160 L	254TC-256TC	3.75	2.91	1.625	1.416	0.375	31.063	12.756	10.551	14.632	9.685	6.575	0.25	8.500	7.250	4x1/2-13	9.724
180	284TD-286TD	4.62	3.28	1.875	1.591	0.500	35.866	14.055	10.551	15.984	10.472	6.575	0.25	11.000	12.500	4x0.81	14.00
180	284TC-286TC	4.38	3.28	1.875	1.591	0.500	33.701	14.055	10.551	15.984	10.472	6.575	0.25	10.500	9.000	4x1/2-13	11.25

BM-BMX

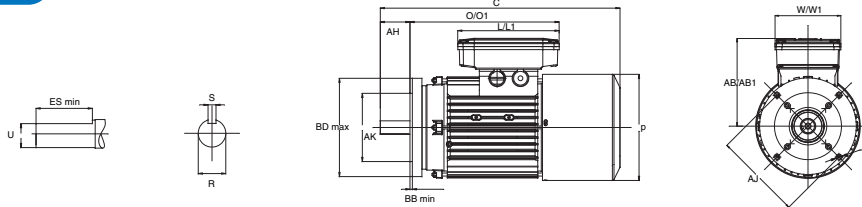

IEC frame size	NEMA flange size	Shaft					Overall dimension						C-Face				
		AH	ES min	U	R	S	C	P	L1	O1	AB1	W1	BB min	AK	AJ	BF	BD max
71	56C	2.06	1.41	0.6250	0.517	0.188	13.071	5.354	5.315	7.756	4.764	3.386	0.16	4.500	5.875	4x3/8-16	6.50
80	56C	2.06	1.41	0.6250	0.517	0.188	14.094	6.024	5.315	8.386	5.118	3.386	0.16	4.500	5.875	4x3/8-16	6.50
90 S	145TC-143TC	2.12	1.41	0.8750	0.771	0.188	14.843	7.009	6.693	8.583	5.827	4.409	0.16	4.500	5.875	4x3/8-16	6.50
90 L	145TC-143TC	2.12	1.41	0.8750	0.771	0.188	15.827	7.009	6.693	9.567	5.827	4.409	0.16	4.500	5.875	4x3/8-16	6.50
100	182TC-184TC	2.62	1.78	1.1250	0.986	0.250	18.110	7.795	6.693	10.295	6.378	4.409	0.25	8.500	7.250	4x1/2-13	9.00
112	182TC-184TC	2.62	1.78	1.1250	0.986	0.250	19.311	8.642	6.693	10.787	6.929	4.409	0.25	8.500	7.250	4x1/2-13	9.00
132 S	213TC-215TC	3.12	2.41	1.3750	1.201	0.312	22.382	10.039	7.835	10.242	8.268	5.945	0.25	8.500	7.250	4x1/2-13	9.00
132 M	213TC-215TC	3.12	2.41	1.3750	1.201	0.312	23.878	10.039	7.835	11.738	8.268	5.945	0.25	8.500	7.250	4x1/2-13	9.00
160 M	254TC-256TC	3.75	2.91	1.625	1.416	0.375	28.346	11.535	10.551	12.900	9.685	6.575	0.25	8.500	7.250	4x1/2-13	9.724
160 L	254TC-256TC	3.75	2.91	1.625	1.416	0.375	30.079	11.535	10.551	14.632	9.685	6.575	0.25	8.500	7.250	4x1/2-13	9.724
180	284TD-286TD	4.62	3.28	1.875	1.591	0.500	36.063	13.976	10.551	15.984	10.472	6.575	0.25	11.000	12.500	4x0.81	14.00
180	284TC-286TC	4.38	3.28	1.875	1.591	0.500	33.701	13.976	10.551	15.984	10.472	6.575	0.25	10.500	9.000	4x1/2-13	11.25

SM-SMX

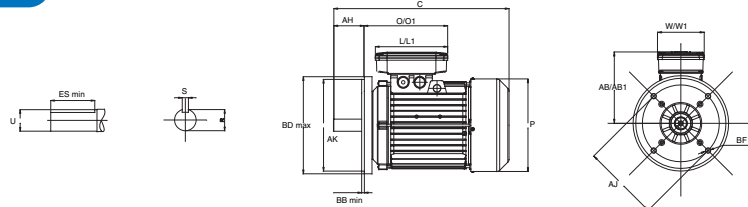

IEC frame size	NEMA flange size	Shaft					Overall dimension						C-Face								
		AH	ES min	U	R	S	C	P	L	L1	O	O1	AB	AB1	W	W1	BB min	AK	AJ	BF	BD max
71	56C	2.06	1.41	0.6250	0.517	0.188	11.380	5.096	3.150	5.315	5.197	6.614	4.134	4.764	2.953	3.386	0.16	4.500	5.875	4x3/8-16	6.50
80	56C	2.06	1.41	0.6250	0.517	0.188	12.165	6.693	3.150	5.315	5.276	6.732	4.449	5.118	2.953	3.386	0.16	4.500	5.875	4x3/8-16	6.50
90 S	145TC-143TC	2.12	1.41	0.8750	0.771	0.188	12.795	7.283	3.878	6.693	6.161	8.583	5.000	5.827	3.878	4.409	0.16	4.500	5.875	4x3/8-16	6.50
90 L	145TC-143TC	2.12	1.41	0.8750	0.771	0.188	13.780	7.283	3.878	6.693	6.161	8.704	5.000	5.827	3.878	4.409	0.16	4.500	5.875	4x3/8-16	6.50
100	182TC-184TC	2.62	1.78	1.1250	0.986	0.250	15.827	7.835	3.878	6.693	6.490	7.907	5.433	6.378	3.878	4.409	0.25	8.500	7.250	4x1/2-13	9.00
112	182TC-184TC	2.62	1.78	1.1250	0.986	0.250	16.270	8.580	3.878	6.693	6.549	7.970	6.220	6.929	3.878	4.409	0.25	8.500	7.250	4x1/2-13	9.00
132 S	213TC-215TC	3.12	2.41	1.3750	1.201	0.312	18.320	10.240	4.252	7.835	7.165	8.720	7.795	8.268	4.252	5.945	0.25	8.500	7.250	4x1/2-13	9.00
132 M	213TC-215TC	3.12	2.41	1.3750	1.201	0.312	19.823	10.240	4.252	7.835	7.165	8.720	7.795	8.268	4.252	5.945	0.25	8.500	7.250	4x1/2-13	9.00
160 M	254TC-256TC	3.75	2.91	1.625	1.416	0.375	23.780	11.535		10.551		12.900		9.685		6.575	0.25	8.500	7.250	4x1/2-13	9.724
160 L	254TC-256TC	3.75	2.91	1.625	1.416	0.375	25.512	11.535		10.551		14.632		9.685		6.575	0.25	8.500	7.250	4x1/2-13	9.724
180	284TD-286TD	4.62	3.28	1.875	1.591	0.500	28.882	13.976		10.551		15.984		10.472		6.575	0.25	11.000	12.500	4x0.81	14.00
180	284TC-286TC	4.38	3.28	1.875	1.591	0.500	27.520	13.976		10.551		15.984		10.472		6.575	0.25	10.500	9.000	4x1/2-13	11.25



NEMA Execution (inch)

Motors With Forced Cooling

AC electric motors operating in non standard conditions (low frequency inverter duty, long overcharge periods, heavy duty cycles) could need additional cooling servo-fan. BASV Series motors with forced cooling are provided with two additional cooling servo-fans fixed on the motor frame. This cooling system is an MGM patent.

SV Series motors have the following features:

1. Two additional cooling servo fans are installed in addition to the standard self-cooling fan.
2. The whole heating surface is increased as the fan fixing system is itself a heat dissipation element, in addition to the existing fins on the frame.
3. Low noise level.
4. Servo ventilation does not add to the motors length.
5. Manual brake release with manual rotation.
6. Uniform winding cooling along the whole motor length.
7. The brake friction surface is cooled on the motor side.

Where forced cooling is used to limit the operating temperature in heavy start/stop duty application, it should be noted that the efficiency of the forced cooling increases with the number of pole of the motor. It's hard to estimate the amount of hot air removed by the forced cooling fans but it can be roughly said that it is the same as the air removed by the standard servo-fan of a 4 pole motor operating at 50 Hz.

It is advisable to use thermal protectors in heavy operating conditions. The table below shows technical details of fans supplied at 230V single-phase. The servo-fans can be supplied both at 50Hz or 60Hz. On request forced cooling fans can be provided with different voltage supply.

Les moteurs freins avec des conditions de fonctionnement particulières (alimentation par variateur de fréquence, surcharge prolongée, etc.) nécessitent une ventilation supplémentaire. La ventilation auxiliaire de la série BASV est assurée par deux ventilateurs fixés latéralement au moteur par un support métallique.

Les moteurs de la série SV ont les caractéristiques suivantes:

1. Outre les ventilateurs auxiliaires, subsiste le ventilateur fixé sur l'arbre du moteur.
2. Augmentation de la superficie dissipatrice des calories par le système de fixation des ventilateurs auxiliaires qui s'ajoute aux ailettes de la carcasse.
3. Faible niveau sonore de ventilation.
4. Longueur du moteur égale à celle du moteur standard sans ventilation auxiliaire.
5. Possibilité de déblocage manuel du frein et rotation manuelle de l'arbre.
6. Refroidissement plus uniforme des enroulements du stator sur toute la longueur du moteur.
7. La plaquette de frein du côté du moteur est aussi refroidie.

Dans le cas de cadences de démarrages élevées, l'efficacité de la ventilation auxiliaire est d'autant plus élevée que le nombre de pôles du moteur est élevé. A titre indicatif, afin de pouvoir vérifier le bilan thermique, la quantité de chaleur dissipée par l'effet de la ventilation auxiliaire seule est comparable à l'effet de la ventilation axiale d'un moteur à 4 pôles. Il est recommandé en cas de services de fonctionnements difficiles de prévoir des sondes de contrôles thermiques dans les enroulements du moteur. Les valeurs du tableau, ci-dessous, correspondent à la tension 230V 50Hz monophasé. Les ventilateurs peuvent être alimentés indifféremment à 50-60 Hz. Sur demande MGM peut livrer des tensions différentes de 230V.

Motor type	Dim X (mm)	Dim Y (mm)	Dim L (mm)	Volt	Watt
BASV 71	210	107	102	1~230	2x16
BASV 80	230	108	120	1~230	2x16
BASV 90	270	129	129	1~230	2x20
BASV 100	280	129	134	1~230	2x20
BASV 112	300	142	142	1~230	2x20
BASV 132	348	169	169	1~230	2x20
BASV 160	431	184	190	1~230	2x36
BASV 180	485	211	211	1~230	2x36
BASV 200	485	211	211	1~230	2x36
BASV 225	522	221	221	1~230	2x36

BMAV and SMAV motors, with axial forced cooling, are also available (the additional servo-fan is located in the rear part of the motor replacing the self-ventilating fan).

Motor type	Dim Q (mm)	Volt	Watt
BMAV-SMAV 56	250	1~230	16
BMAV-SMAV 63	280	1~230	16
BMAV-SMAV 71	315	1~230	16
BMAV-SMAV 80	364	1~230	16
BMAV-SMAV 90	390	1~230	36
BMAV-SMAV 100	415	1~230	36
BMAV-SMAV 112	465	1~230	36
BMAV-SMAV 132	604	3~400	93
BMAV-SMAV 160	734	3~400	93
BMAV-SMAV 180	825	3~400	123
BMAV-SMAV 200	825	3~400	123
BMAV-SMAV 225	1065	3~400	123

BASV Series

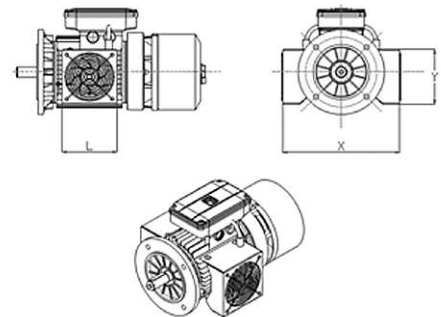

Sur demande, si la motoventilation radiale de la série BASV ne convient pas, il est également possible de construire des moteurs de la série BM et SM dans la version BMAV et SMAV avec une ventilation auxiliaire axiale (le ventilateur est situé à l'arrière du moteur, à la place du ventilateur principal).

BMAV-SMAV Series

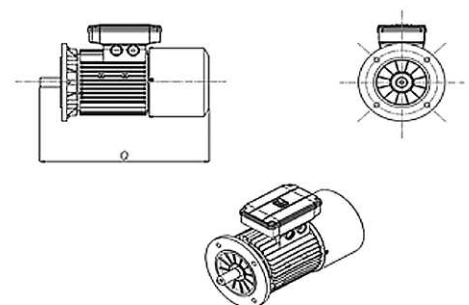

MGM manufactures two series of brake motors with built-in Encoder:

BAE Series: Asynchronous three phase fan cooled brake motor with a built-in encoder from frame sizes 71 up to 280. The encoder is located at the nondrive end in a safe place protected by a well closed cover. Forced ventilation is available on request. The motor is provided as standard with separate brake supply. The brake coil is AC as standard, while DC is available on request.

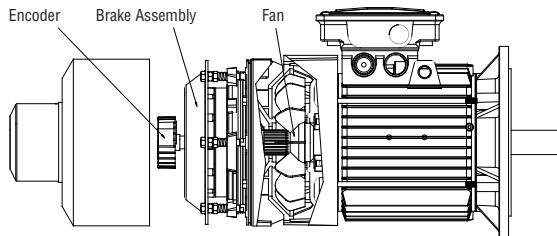

BMEAV Series: Asynchronous three phase fan cooled brake motor with a DC brake, axial forced ventilation, and a built-in encoder from frame sizes 63 up to 280. The encoder is located at the nondrive end between the brake and servo fan. The motor is supplied as standard with separate brake supply. Side manual return brake release is available on request.

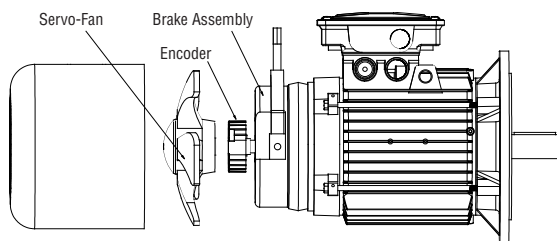

SMEAV Series: Asynchronous three phase fan cooled motor without brake, axial forced ventilation, and a built-in encoder from frame sizes 63 up to 225. The encoder is located at the nondrive end.

BAE, BMEAV and SMEAV Series motors are ready to be supplied by a VFD (inverter). These motor series are manufactured with high grade dynamic balancing and with a winding insulation capable of withstanding higher electrical and mechanical stresses.

The dimensions and couplings are the same as those of a standard motor (special shaft and flanges are available on request). Wiring connections are easy to carry out and power leads are isolated from control leads.

cCSAus approval is available.

Encoder mounted motors

The following specifications are required to select the proper encoder:

- Encoder type (incremental - absolute)
- Pulses Per Round (PPR)
- Zero Pulse (with / without)
- Supply Voltage of the Encoder
- Electronic Output Configuration
- IP Enclosure (On BAE motors the encoder comes totally enclosed underneath a protection cover)
- Encoder Interface
- Code (for absolute encoder only)
- Single Turn or Multi Turn

The Encoder output cable is available with a connector or with loose wires.

Contact MGM for further specifications.

Deux différentes séries de moteur avec frein et codeur intégré sont disponibles:

Série BAE: moteur frein asynchrone autoventilés avec codeur intégré pour hauteur d'axe entre 71 mm et 280 mm. Le codeur est monté à l'arrière du moteur et protégé par un capot fermé. Le kit de ventilation auxiliaire (2 ventilateurs latéraux) est disponible sur demande. L'alimentation du frein est séparé du moteur de série. La bobine de frein est AC de série mais la bobine DC est disponible sur demande.

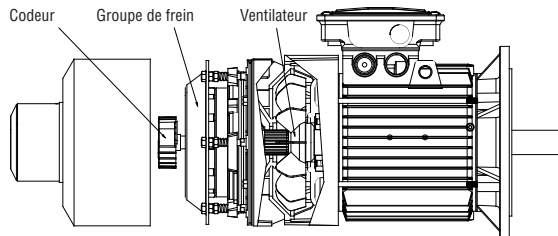

Série BMEAV: moteur asynchrone triphasé avec bobine de frein DC, ventilation auxiliaire axial forcé et codeur intégré pour hauteur d'axe comprise entre 63 mm et 225 mm. Le codeur est monté entre le groupe de frein et le ventilateur. L'alimentation du frein est séparé du moteur de série. Le levier de déblocage manuel du frein est disponible sur demande.

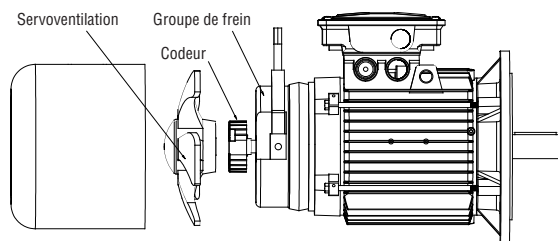

Série SMEAV: moteur asynchrone triphasé avec ventilation auxiliaire axial forcé et codeur intégré pour hauteur d'axe comprise entre 63 mm et 225 mm.

Les moteurs de la série **BAE, BMEAV et SMEAV** sont adaptés pour être utilisés avec un variateur de fréquence; à cet effet il est prévu un équilibrage dynamique soigné et un renforcement des couches isolantes pour résister à l'augmentation des sollicitations électriques et mécaniques.

Le couplage mécanique est le même que pour un moteur standard (arbre et bride spécial sont disponible sur demande). Les connexions électriques sont simples, la partie puissance et la partie commande étant séparées. Sur demande, les moteurs peuvent être fournis avec la certification cCSAus.

Codeur

Les caractéristiques nécessaire pour définir un codeur montés sur un moteur sont:

- type de codeur (incrémental ou absolu)
- résolution du codeur.
- impulsion du zéro
- tension d'alimentation du codeur.
- configuration électronique de sortie.
- IP (Sur la série BAE, les codeurs sont protégé par un capot métallique fermé)
- type d'interface.
- le code (codeur absolue uniquement)
- mono-tour ou multi-tour (codeur absolue uniquement)

Les codeurs sont disponibles avec un câble de connexion standard ou un connecteur spécial sur demande.

Pour les demandes spéciales, contacté MGM.



MGM Electric Motors

Italy

Head office and production

S/R 435 Lucchese Km 31
I - 51030 Serravalle Pistoiese (PT) - ITALY
Tel. +39 0573 91511 (r.a.)
Fax +39 0573 518138
Web www.mgmrestop.com
E-mail mgm@mgmrestop.com

North Italy branch office

I - 20090 Assago Milano - Via Fermi, 44
Tel. +39 02 48843593 - Fax +39 02 48842837

Canada

Head office and production

3600 F.X. Tessier, Unit # 140
Vaudreuil, Quebec J7V 5V5 - CANADA
Sales (877) 355 4343
Tel. +1 (514) 355 4343 - Fax +1 (514) 355 5199
Web www.mgmelectricmotors.com
E-mail info@mgmelectricmotors.com

USA

Head office

24715 Crestview Court
Farmington Hills, MI 48335 - USA
Tel. +1 (248) 987 6572 - Fax +1 (248) 987 6569
Web www.mgmelectricmotors.com
E-mail infousa@mgmelectricmotors.com

India

Head office and production

Door No. 68, Indus Valley's Logistic Park
Unit 3, Mel Ayanambakkam, Vellala Street
Chennai 600 095, Tamil Nadu - INDIA
Tel. +91 44 64627008
Web www.mgmvarvelindia.com
E-mail info@mgmvarvelindia.com

Turkey

Head office and production

İTOB Organize Sanayi Bölgesi,
Ekrem Demirtaş cd. No: 28 Menderes
İzmir - TURKEY
Tel. +90 232 799 0347 - Fax +90 232 799 0348
Web www.mgmmotor.com.tr
E-mail info@mgmmotor.com.tr