

INSTALLATION DIMENSIONS

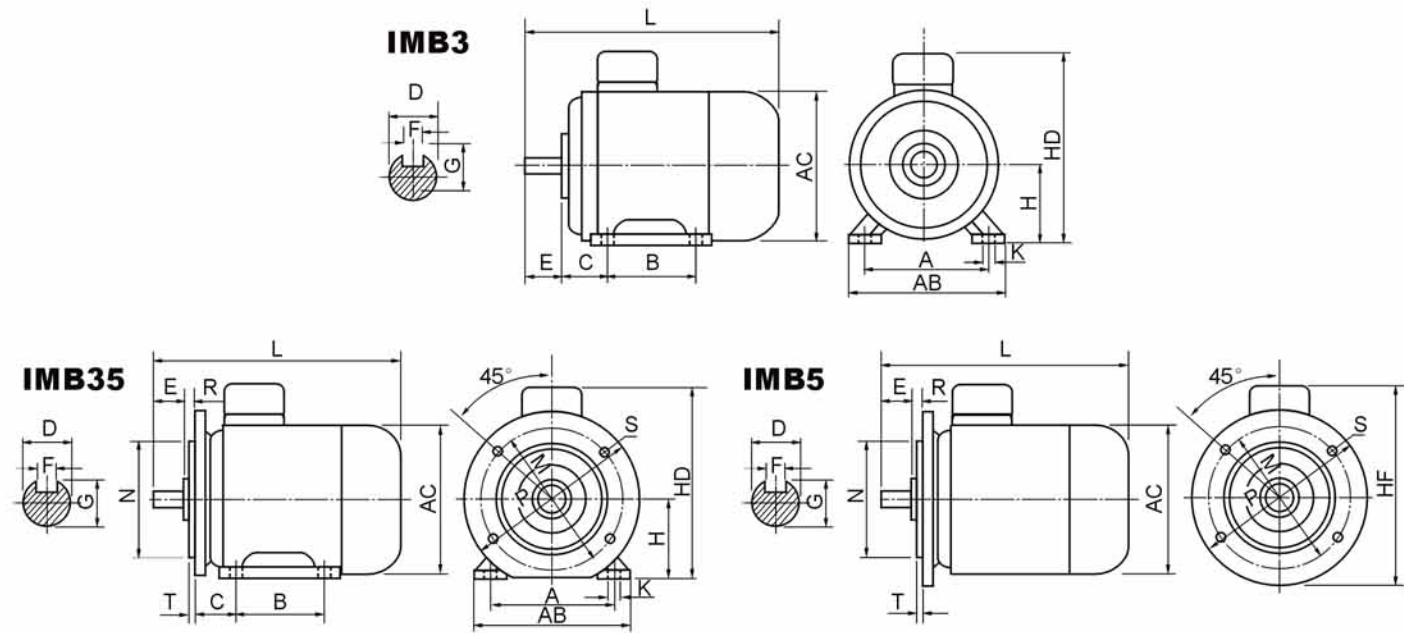

Frame Size	Mounting Dimensions(mm)																Frame Dimensions(mm)								
	A	B	C	D		E		F		G		H	K	M	N	P	R	S	T	AB	AC	AD	HD	L	
				2P	4,6,8,10P	2P	4,6,8,10P	2P	4,6,8,10P	2P	4,6,8,10P												2P	4,6,8,10P	
63	100	80	40	11	23	4	8.5	63	7	115	95	140	0	10	3	135	130	70	180	230					
71	112	90	45	14	30	5	11	71	7	130	110	160	0	10	3	150	145	80	195	255					
80	125	100	50	19	40	6	15.5	80	10	165	130	200	0	12	3.5	165	175	145	220	295					
90S	140	100	56	24	50	8	20	90	10	165	130	200	0	12	3.5	180	195	155	250	320					
90L	140	125	56	24	50	8	20	90	10	165	130	200	0	12	3.5	180	195	155	250	345					
100L	160	140	63	28	60	8	24	100	12	215	180	250	0	15	4	205	215	180	270	385					
112M	190	140	70	28	60	8	24	112	12	215	180	250	0	15	4	230	240	190	300	400					
132S	216	140	89	38	80	10	33	132	12	265	230	300	0	15	4	270	275	210	345	470					
132M	216	178	89	38	80	10	33	132	12	265	230	300	0	15	4	270	275	210	345	510					
160M	254	210	108	42	110	12	37	160	15	300	250	350	0	19	5	320	330	255	420	615					
160L	254	254	108	42	110	12	37	160	15	300	250	350	0	19	5	320	330	255	420	670					
180M	279	241	121	48	110	14	42.5	180	15	300	250	350	0	19	5	355	380	280	455	700					
180L	279	279	121	48	110	14	42.5	180	15	300	250	350	0	19	5	355	380	280	455	740					
200L	318	305	133	55	110	16	49	200	19	350	300	400	0	19	5	395	420	305	505	770					
225S	356	286	149	-	60	-	140	-	18	-	53	225	19	400	350	450	0	19	5	435	470	335	560	-	820
225M	356	311	149	55	60	110	140	16	18	49	53	225	19	400	350	450	0	19	5	435	470	335	560	815	845
250M	406	349	168	60	65	140	180	18	20	58	58	250	24	500	450	550	0	19	5	490	510	370	615	910	
280S	457	368	190	65	75	140	180	20	20	58	67.5	280	24	500	450	550	0	19	5	550	580	410	680	985	
280M	457	419	190	65	75	140	180	20	20	58	67.5	280	24	500	450	550	0	19	5	550	580	410	680	1035	
315S	508	406	216	65	80	140	170	18	22	58	71	315	28	600	550	660	0	24	6	635	645	630	845	1185	1215
315M	508	457	216	65	80	140	170	18	22	58	71	315	28	600	550	660	0	24	6	635	645	630	845	1295	1325
315L	508	508	216	65	80	140	170	18	22	58	71	315	28	600	550	660	0	24	6	635	645	630	845	1295	1325
355M	610	560	254	75	95	140	170	20	25	67.5	86	355	28	740	680	800	0	24	6	730	710	655	1010	1500	1530
355L	610	630	254	75	95	140	170	20	25	67.5	86	355	28	740	680	800	0	24	6	730	710	655	1010	1500	1530



# PEM SERIES THREE-PHASE INDUCTION MOTORS

These three phase motors are made to IEC standards. These are superior motors having excellent power factors efficiencies and starting torques. These motors are widely used in the agricultural, pumping, manufacturing and building service industries.

**MOTOR FEATURES**

- IP54 enclosure, IP55 available on request
- Class F insulation, Class H available on request
- 380/415 Volt 50/60 Hz windings
- High quality magnet wire
- Vacuum varnish impregnation for superior tropic proof insulation
- Continuous SI operation
- Industrial type service factors
- Heavy duty ball bearings
- High strength cast iron frame
- Balanced rotors

**CUSTOMER BENEFITS**

- Water dust and vermin resistant
- Quiet operation
- Corrosion resistant
- Reliable in country, city or factory environments
- Very low vibration
- Very low power consumption
- Superior life

**PARAGON PUMP COMPANY, LLC**  
 18102 Courtney Breeze Drive  
 Tampa, Florida, 33647, USA  
 Tel : (813) 994-3356  
 Fax: (813) 994-1237

**PARAGON PUMP (ASIA) PTE LTD**  
 37 Kallang Pudding Road #08-08  
 Tong Lee Building Block B  
 Singapore 349315  
 Tel : (65) 6841-2818  
 Fax: (65) 6841-5988

TECHNICAL DATA

Model	Output		Speed r/min	FLC			Efficiency			Power factor			Tn Nm	Ts Tn	Tmax Tn	Is In	Moment J	Noise LwdB(A)	Weight kg
	kW	HP		380V A	400V A	415V A	100%	75%	50%	100%	75%	50%							
SPEED 3000RPM 2-POLES 50Hz																			
PEM631-2	0.18	0.25	2825	0.52	0.5	0.48	65	64	60	0.80	0.73	0.66	0.61	2.2	2.2	5.5	0.0031	61	14
PEM632-2	0.25	0.37	2840	0.69	0.66	0.64	68	68.5	66	0.81	0.74	0.67	0.96	2.2	2.2	5.1	0.0004	61	14.5
PEM711-2	0.37	0.5	2840	0.99	0.94	0.91	70	71	68.5	0.81	0.75	0.66	1.26	2.2	2.2	6.0	0.00055	64	15
PEM712-2	0.55	0.75	2880	1.4	1.33	1.28	73	73	69.5	0.82	0.76	0.69	1.88	2.2	2.2	6.0	0.0006	64	15.5
PEM801-2	0.75	1	2890	1.8	1.73	1.67	75	75.7	72.3	0.83	0.78	0.67	2.54	2.2	2.2	6.0	0.00075	67	16.5
PEM802-2	1.1	1.5	2900	2.6	2.46	2.37	77	80	78.2	0.84	0.82	0.72	3.72	2.2	2.2	7.0	0.0009	67	17.5
PEM90S-2	1.5	2	2900	3.4	3.26	3.14	79	80.2	77.3	0.84	0.80	0.70	5.04	2.2	2.2	7.0	0.0012	72	21
PEM90L-2	2.2	3	2930	4.8	4.61	4.44	81	82.7	81.6	0.85	0.84	0.74	7.40	2.2	2.2	7.0	0.0014	72	25
PEM100L-2	3	4	2930	6.3	6.01	5.79	83	83.4	81.3	0.87	0.85	0.76	9.95	2.2	2.2	7.0	0.0029	76	33
PEM112M-2	4	5.5	2930	8.1	7.69	7.41	85	85.5	83.5	0.88	0.85	0.76	13.22	2.2	2.2	8.0	0.0055	77	41
PEM132S1-2	5.5	7.5	2940	11	10.5	10.12	86	84.5	81.5	0.88	0.88	0.82	18.11	2.2	2.2	8.0	0.0109	80	63
PEM132S2-2	7.5	10	2950	15	14.2	13.69	87	86.9	85.3	0.88	0.89	0.84	24.70	2.2	2.2	8.0	0.0126	80	70
PEM160M1-2	11	15	2950	21.3	20.2	19.47	88	87.4	85.3	0.88	0.87	0.83	35.85	2.0	2.2	8.0	0.0377	86	110
PEM160M2-2	15	20	2970	28.7	27.4	26.5	89	88.5	86.2	0.89	0.88	0.83	48.89	2.0	2.2	8.0	0.0499	86	120
PEM160L-2	18.5	25	2970	34.6	32.9	31.7	90	90.2	88.6	0.90	0.90	0.87	60.30	2.0	2.2	8.0	0.055	86	135
PEM180M-2	22	30	2970	40.9	38.9	37.5	90.5	89.9	87.7	0.90	0.89	0.85	71.46	2.0	2.2	8.0	0.075	89	165
PEM200L1-2	30	40	2970	55.4	52.7	50.8	91.2	90.3	87.7	0.90	0.83	0.75	97.12	2.0	2.2	8.0	0.124	92	218
PEM200L2-2	37	50	2980	67.7	64.5	62.2	92	91.2	89.3	0.90	0.87	0.81	119.78	2.0	2.2	8.0	0.139	92	230
PEM225M-2	45	60	2980	82.3	78.2	75.4	92.3	90.9	88.4	0.90	0.88	0.84	144.70	1.8	2.2	8.0	0.233	92	280
PEM250M-2	55	75	2980	101	95.9	92.4	92.5	91.9	89.2	0.90	0.84	0.78	176.85	1.8	2.2	7.0	0.312	93	365
PEM280S-2	75	100	2980	134	127.3	122.7	93	93.1	81.5	0.90	0.88	0.84	241.16	1.8	2.2	7.0	0.579	94	495
PEM280M-2	90	125	2980	160	152	146.5	93.8	93.1	92.1	0.91	0.87	0.85	289.39	1.8	2.2	7.0	0.675	94	565
PEM315S-2	110	150	2980	195	185.3	178.6	94	93.9	92.4	0.91	0.87	0.82	352.51	1.8	2.2	6.8	1.18	96	890
PEM315M-2	132	180	2980	233	221.4	213.4	94.5	94.3	92.8	0.91	0.85	0.80	423.02	1.8	2.2	6.8	1.82	96	980
PEM315L1-2	160	220	2980	279	265	255.4	94.6	94.5	93	0.92	0.88	0.82	512.75	1.8	2.2	6.8	2.08	99	1055
PEM315L2-2	200	270	2980	348	330	318	94.8	94.5	93	0.92	0.88	0.82	640.94	1.8	2.2	6.8	2.38	99	1110
PEM355M-2	250	340	2980	433	411	396	95.3	94	92.5	0.92	0.88	0.81	799.83	1.6	2.2	7.0	3.00	103	1900
PEM355L-2	315	430	2980	544	517	498.3	95.6	95.2	94	0.92	0.89	0.81	1007.9	1.6	2.2	7.1	3.50	103	2300
SPEED 1500RPM 4-POLES 50Hz																			
PEM631-4	0.12	0.18	1400	0.44	0.4	0.39	57	59	56	0.72	0.63	0.57	0.84	2.2	2.2	4.5	0.0002	52	13
PEM632-4	0.18	0.25	1400	0.62	0.6	0.58	60	61.6	57.5	0.73	0.65	0.57	1.26	2.2	2.2	4.5	0.0003	52	13.5
PEM711-4	0.25	0.37	1400	0.79	0.7	0.67	65	69.3	60.1	0.74	0.65	0.58	1.73	2.2	2.2	5.5	0.0006	55	14
PEM712-4	0.37	0.5	1400	1.12	1.06	1.02	67	71	68.4	0.75	0.65	0.52	2.54	2.2	2.2	5.5	0.0008	55	14.5
PEM801-4	0.55	0.75	1400	1.6	1.49	1.44	71	72.6	69	0.75	0.66	0.55	3.78	2.2	2.2	5.5	0.0018	58	15
PEM802-4	0.75	1	1400	2.0	1.93	1.86	73	74.2	70	0.77	0.65	0.54	5.15	2.2	2.2	6.0	0.0021	58	16
PEM90S-4	1.1	1.5	1400	2.9	2.75	2.65	75	77.8	75	0.77	0.70	0.57	7.50	2.2	2.2	6.0	0.0023	61	23
PEM90L-4	1.5	2	1400	3.7	3.52	3.39	78	78.1	76.7	0.79	0.75	0.64	10.23	2.2	2.2	6.0	0.0027	61	25
PEM100L1-4	2.2	3	1420	5.1	4.9	4.72	80	83	81	0.81	0.76	0.65	14.80	2.2	2.2	7.0	0.0054	64	33
PEM100L2-4	3	4	1420	6.8	6.44	6.21	82	83.2	81.6	0.82	0.78	0.66	20.18	2.2	2.2	7.0	0.0067	64	35
PEM112M-4	4	5.5	1440	8.8	8.36	8.06	84	84.8	82.7	0.82	0.76	0.64	26.53	2.2	2.2	7.0	0.0095	65	41
PEM132S-4	5.5	7.5	1440	11.8	11.2	10.8	85	86.8	85.6	0.83	0.81	0.71	36.48	2.2	2.2	7.0	0.0214	71	65
PEM132M-4	7.5	10	1440	15.5	14.8	14.3	87	88.2	87.2	0.84	0.83	0.74	49.74	2.0	2.0	7.0	0.0296	71	76
PEM160M-4	11	15	1460	22.3	21.1	20.3	88	89.2	87.8	0.85	0.83	0.75	71.59	2.0	2.2	7.0	0.0747	75	118
PEM160L-4	15	20	1460	30	28.6	27.6	89	89.7	88.4	0.85	0.82	0.75	98.12	2.0	2.2	7.0	0.0978	75	132
PEM180M-4	18.5	25	1470	36.4	34.6	33.4	90.5	90.6	89.7	0.85	0.86	0.77	120.19	2.2	2.2	7.5	0.139	76	164
PEM180L-4	22	30	1470	43.1	41	39.5	91	91.7	90.2	0.85	0.85	0.75	142.93	2.2	2.2	7.5	0.158	76	182
PEM200L-4	30	40	1470	57.4	54.7	52.7	92	92.4	91.6	0.86	0.84	0.75	160.96	2.2	2.2	7.5	0.262	79	245
PEM225S-4	37	50	1480	69.9	66.4	64	92.5	92.7	91.5	0.87	0.84	0.75	198.51	2.2	2.2	7.5	0.406	81	258
PEM225M-4	45	60	1480	84.7	80.4	77.5	92.8	93.3	92.5	0.87	0.87	0.81	290.37	2.2	2.2	7.5	0.469	81	290
PEM250M-4	55	75	1480	103	97.8	94.3	93	94.2	93.6	0.89	0.88	0.82	354.90	2.2	2.2	7.0	0.66	83	388
PEM280S-4	75	100	1480	140	133	128.2	93.8	93.5	92.0	0.86	0.89	0.84	483.95	2.2	2.2	7.0	1.12	86	510
PEM280M-4	90	125	1490	167	158.7	152.9	94.2	93.5	91.8	0.86	0.86	0.80	578.79	2.2	2.2	7.0	1.46	86	606
PEM315S-4	110	150	1490	201	191	184	94.5	93.5	91.4	0.87	0.87	0.81	707.41	2.1	2.2	6.9	3.11	93	910
PEM315M-4	132	180	1490	240	228	219.8	94.8	94.8	93.3	0.87	0.88	0.82	848.89	2.1	2.2	6.9	3.62	93	1000
PEM315L1-4	160	220	1490	287	273	263.1	94.9	94.5	93.5	0.88	0.85	0.78	1028.96	2.1	2.2	6.9	4.13	97	1055
PEM315L2-4	200	270	1490	359	341	328.7	95	94.1	92.7	0.88	0.87	0.81	1286.20	2.3	2.2	6.9	4.73	88	1128
PEM355M-4	250	340	1485	443	421	405.8	95.3	94.4	93.4	0.88	0.87	0.79	1602.35	2.3	2.2	6.8	6.5	101	1700
PEM355L-4	315	430	1485	556	528	508.9	95.6	95	93.8	0.89	0.86	0.79	2018.96	2.2	2.2	6.9	8.2	101	1900

TECHNICAL DATA

Model	Output		Speed r/min	FLC			Efficiency			Power factor			Tn Nm	Ts Tn	Tmax Tn	Is In	Moment J	Noise LwdB(A)	Weight kg
	kW	HP		380V A	400V A	415V A	100%	75%	50%	100%	75%	50%							
SPEED 1000RPM 6-POLES 50Hz																			
PEM711-6	0.18	0.25	900	0.74	0.7	0.67	56	57	53.1	0.66	0.60	0.52	1.91	2.2	2.2	4.0	0.0011	52	14
PEM712-6	0.25	0.37	900	0.94	0.9	0.87	59	59.9	55.2	0.68	0.60	0.53	2.65	2.0	2.2	4.0	0.014	52	14.5
PEM801-6	0.37	0.5	900	1.3	1.24	1.12	62	67.7	64.2	0.70	0.62	0.49	3.33	2.0	2.2	5.0	0.0016	54	15
PEM802-6	0.55	0.75	900	1.8	1.7	1.64	65	68.4	64.1	0.72	0.59	0.47	5.84	2.0	2.2	5.0	0.019	54	16
PEM90S-6	0.75	1	910	2.3	2.18	2.1	69	73.9	70.6	0.72	0.64	0.52	7.87	2.0	2.2	5.5	0.0029	57	19
PEM90L-6	1.1	1.5	910	3.2	3.03	2.92	72	74.7	72.1	0.73	0.66	0.53	11.54	2.0	2.2	5.5	0.0035	57	22
PEM100L-6	1.5	2																	