

LSES high efficiency three-phase asynchronous motors



General information



Efficiency class IE2

Totally enclosed three-phase power-saving asynchronous motors, LSES series, according to IEC 60034, 60038, 60072 ; power 0.75 to 200 kW, frame size 80 to 315 mm.
Single speed: 2,4 and 6 poles; 230/400 V or 400 V Δ , 50 Hz.

The selection tables for motors in this catalogue allow for:

- Direct on line starting on the mains supplies 230 V or 400 V operating in:
 - delta connection (Δ) at 230 V,
 - star connection (Y) at 400 V.
- Star/ delta start (Y/ Δ) on mains supply 400 V with:
 - star connection (Y) during initial starting,
 - delta connection (Δ) on 400 V duty.

Finish

Assembled with protected screws.
RAL 6000 finishing paint (green).
Protection of the flange and shaft end against atmospheric corrosion.

Mains supply

- Standard according to IEC 60038:
 - 230/400 V +10% -10% at 50 Hz.

Voltages for the powers equal or greater than 3 kW:

- 400 V Δ +10% -10% at 50 Hz,

Construction suitable for Y/ Δ starting.

Description of LSES aluminium three-phase motors

Component	Materials	Remarks
Housing with cooling fins	Aluminium alloy	- with integral or screw-on feet, or without feet - 4 or 6 fixing holes for housings with feet - lifting rings for frame size \geq 100 - earth terminal with an optional jumper screw
Stator	Insulated low carbon magnetic steel laminations Electroplated copper	- low carbon content guarantees long-term lamination pack stability - semi-enclosed slots - class F insulation
Rotor	Insulated low carbon magnetic steel laminations Aluminium	- inclined cage bars - rotor cage pressure die cast in aluminium (or alloy for special applications) - shrink-fitted to shaft - rotor balanced dynamically, 1/2 key
Shaft	Steel	- for frame size \leq 160 MP - LR: • tapped hole • closed keyway - for frame size \geq 160 M - L : • tapped hole • open keyway
End shields	Aluminium alloy Cast iron	- LS 80 - 90 non drive end - LS 80 - 90 drive end (except for 6 pole, optional for LS 80 and 90 at non drive end) - LS 100 to 315 drive end and non drive end
Bearings and lubrication		- ball bearings "greased for life" from frame size 80 to 225 inclusive - ball bearings regreasable from frame size 250 to 315 - bearings preloaded at non drive end
Labyrinth seals Lipseals	Plastic or steel Synthetic rubber	- lipseal or deflector at drive end for all flange mounted motors - lipseal, deflector or labyrinth seals for foot mounted motors
Fan	Composite material or aluminium alloy	- 2 directions of rotation: straight blades
Fan cover	Composite material or pressed steel	- on request, fitted with a drip cover for operation in vertical position, shaft end facing down
Terminal box	Composite material or aluminium alloy	- IP 55 - can be turned on, opposite side to feet - fitted with a terminal block with 6 steel terminals as standard (brass as an option) - terminal box fitted with threaded plugs, supplied without cable glands (cable glands as an option) - 1 earth terminal in each terminal box - fixation system cover with captive screws

LSES high efficiency three-phase asynchronous motors



Mounting positions

Foot mounted motors

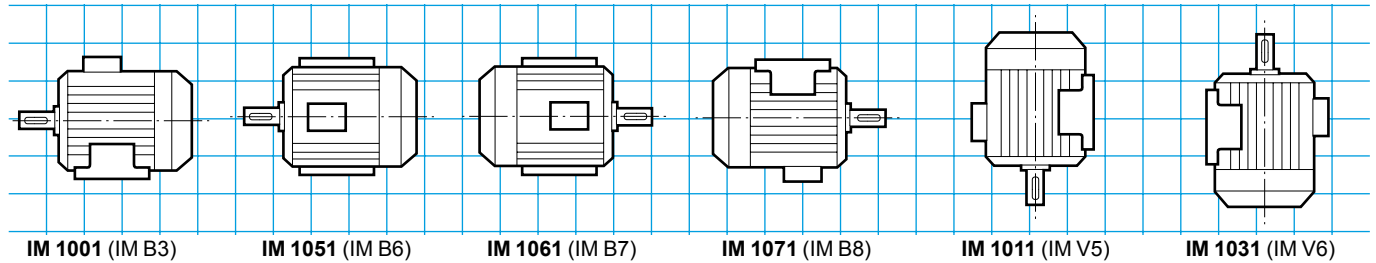

(FF) plain hole flange mounted motors

• Possible position IM 3001 (IM B5) up to 225 frame size inclusive

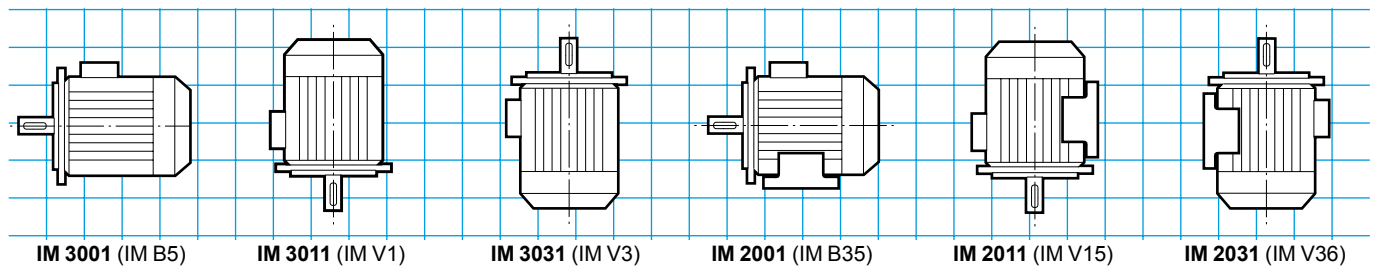

(FT) tapped hole flange mounted motors

• Possible positions up to 132 frame size inclusive

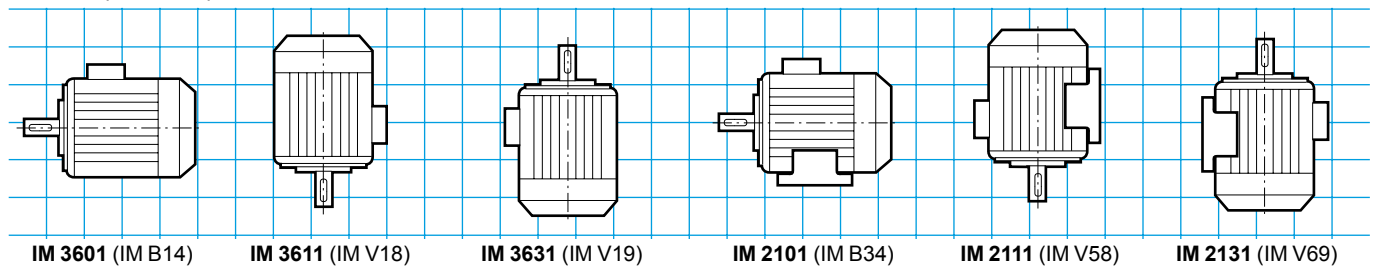

Terminal box position in relation to the motor shaft end

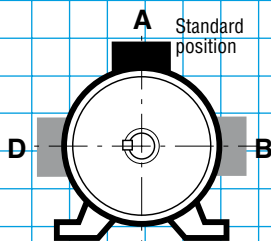

A: standard

Cable gland position in relation to the motor shaft end

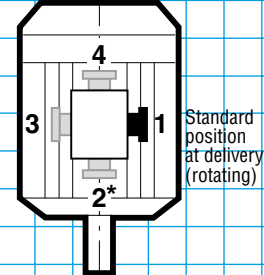

1: standard

* Position 2 not recommended and not feasible on plain hole flange standard motor (FF)

LSES high efficiency three-phase asynchronous motors



Selection

IP 55 - 50 Hz - Class F - Δ T 80 K - 230 V Δ / 400 V Y and 400 V Δ - S1 - Class IE2

2
poles
3000 min⁻¹

IE2

Type	Rated power	Rated speed	Rated torque	Rated current	Power factor			Efficiency IEC 60034-2-1 2007			Starting current/ Rated current	Starting torque/ Rated torque	Maximum torque/ Rated torque	Moment of inertia	Weight	Noise
	P_N	N_N	M_N	$I_{N(400V)}$	Cos ϕ			η			I_d / I_n	M_d / M_n	M_v / M_n	J	IMB3	LP
	kW	min ⁻¹	N.m	A	4/4	3/4	2/4	4/4	3/4	2/4				kg.m ²	kg	db(A)
LS 56 M*	0.09	2860	0.3	0.44	0.55	0.45	0.40	54.0	45.2	37.1	5.0	5.3	5.4	0.00015	3.8	54
LS 56 M*	0.12	2820	0.4	0.5	0.60	0.55	0.45	58.7	54	45.2	4.6	4.0	4.1	0.00015	3.8	54
LS 63 M*	0.18	2790	0.6	0.5	0.75	0.65	0.55	67.4	66.9	59.3	5.0	3.3	2.9	0.00019	4.8	57
LS 63 M*	0.25	2800	0.9	0.7	0.75	0.65	0.55	67.8	67.3	59.2	5.4	3.2	2.9	0.00025	6	57
LS 71 L*	0.37	2800	1.3	1.0	0.80	0.70	0.60	68.4	67.6	63.9	5.2	3.3	3.9	0.00035	6.4	62
LS 71 L*	0.55	2800	1.9	1.3	0.80	0.70	0.55	75.7	75.2	71.1	6.0	3.2	3.1	0.00045	7.3	62
LSES 80 L	0.75	2860	2.5	1.7	0.85	0.77	0.66	78.6	78.8	77.2	6.0	2.4	3.0	0.00073	9.5	61
LSES 80 L	1.1	2845	3.7	2.3	0.85	0.78	0.64	79.7	80.9	79.2	7.0	2.8	3.4	0.00095	10.7	61
LSES 90 S	1.5	2860	5.0	3.2	0.84	0.76	0.62	81.7	82.3	80.6	7.8	3.4	4.5	0.00149	12.9	64
LSES 90 L	2.2	2870	7.2	4.5	0.84	0.76	0.63	83.7	83.7	81.6	8.7	4.0	4.1	0.00197	16.1	64
LSES 100 L	3	2870	10.0	5.9	0.87	0.81	0.69	84.8	85.5	84.4	8.5	4.0	4.0	0.00267	22.2	66
LSES 112 MR	4	2864	13.4	7.9	0.85	0.79	0.66	86.2	86.9	86.0	8.6	4.2	3.7	0.00323	26.5	66
LSES 132 S	5.5	2923	17.9	10.0	0.90	0.86	0.76	88.1	88.9	88.4	8.3	2.5	3.5	0.00881	35	72
LSES 132 SU	7.5	2923	24.1	13.3	0.91	0.88	0.79	88.1	88.9	88.9	8.6	2.7	3.1	0.01096	41	72
LSES 160 MP	11	2927	35.9	21.2	0.84	0.77	0.66	89.6	90.1	89.4	8.3	3.6	4.6	0.01940	63	72
LSES 160 MR	15	2928	49.2	27.2	0.89	0.84	0.75	90.4	91.4	91.3	9.0	2.7	3.8	0.02560	75	72
LSES 160 L	18.5	2944	60.1	32.9	0.89	0.86	0.79	91.5	91.9	91.4	8.4	2.9	3.0	0.05000	101	72
LSES 180 MT	22	2938	71.9	38.9	0.89	0.87	0.80	91.8	92.3	91.9	8.4	2.7	3.2	0.06000	105	69
LSES 200 LR	30	2952	97.3	51.2	0.92	0.90	0.85	92.3	92.7	92.1	8.6	3.0	3.5	0.10000	155	77
LSES 200 L	37	2943	119	64.8	0.89	0.87	0.81	92.6	93.1	92.7	7.1	2.2	2.5	0.12000	182	73
LSES 225 MT	45	2953	145	79.5	0.88	0.85	0.78	93.1	93.4	92.8	7.9	3.0	3.4	0.14000	203	73
LSES 250 MZ	55	2950	179	95.7	0.89	0.86	0.80	93.5	93.8	93.4	7.9	3.0	3.3	0.17000	238	76
LSES 280 SC	75	2967	241	128	0.90	0.88	0.82	94.3	94.5	93.9	8.2	2.7	3.0	0.36000	340	81
LSES 280 MC	90	2969	287	153	0.90	0.88	0.82	94.6	94.8	94.3	8.4	2.8	3.4	0.43000	370	80
LSES 315 SN	110	2964	353	185	0.91	0.90	0.86	94.4	94.9	94.7	8.3	2.8	3.3	0.55000	447	80
LSES 315 MP	132	2976	425	223	0.89	0.88	0.83	94.9	94.7	93.7	7.6	2.8	3.0	1.67000	718	84
LSES 315 MR	160	2975	512	270	0.90	0.89	0.85	94.9	94.8	94.0	7.6	2.9	3.1	1.97000	823	83
LSES 315 MR	200	2982	641	348	0.88	0.83	0.75	95.3	94.8	93.4	8.7	3.8	3.9	2.05000	849	85

* Motors nonconcerned by IE2

Non standards powers

Type	Rated power	Rated speed	Rated torque	Rated current	Power factor			Efficiency IEC 60034-2-1 2007			Starting current/ Rated current	Starting torque/ Rated torque	Maximum torque/ Rated torque	Moment of inertia	Weight	Noise
	P_N	N_N	M_N	$I_{N(400V)}$	Cos ϕ			η			I_d / I_n	M_d / M_n	M_v / M_n	J	IMB3	LP
	kW	min ⁻¹	N.m	A	4/4	3/4	2/4	4/4	3/4	2/4				kg.m ²	kg	db(A)
LSES 71 LG	0.75	2825	2.5	1.7	0.83	0.76	0.64	77.7	77.7	74.8	6.4	3.4	3.4	0.000692	7.5	62
LSES 80 LG	1.5	2860	5.0	3.2	0.87	0.76	0.62	81.7	82.3	80.6	7.8	3.4	4.5	0.00150	13	64
LSES 90 L	1.8	2874	6	3.6	0.87	0.81	0.69	83.3	83.5	81.9	8.6	4.3	4.3	0.00169	14.5	64
LSES 100 L	3.7	2867	12	7.5	0.83	0.76	0.65	85.7	85.8	84.4	8.8	4.2	3.6	0.00291	24	66
LSES 112 MG	5.5	2922	17.9	8.3	0.91	0.87	0.79	87.4	88.2	87.6	8.3	2.5	3.5	0.00855	33	72
LSES 132 M	9	2925	29.2	17.7	0.82	0.75	0.63	89.5	89.8	89.2	8.0	3.5	3.6	0.0164	50	72
LSES 132 M	11	2927	35.9	21.2	0.84	0.77	0.66	89.6	90.1	89.4	8.3	3.6	4.6	0.0194	55	72
LSES 200 LR	40	2963	129	72.6	0.86	0.81	0.70	92.6	92.2	90.7	10.7	3.9	4.6	0.10	170	73
LSES 200 LU	55	2963	179	95.7	0.89	0.86	0.80	93.5	93.8	93.4	7.9	3.0	3.3	0.17	225	73
LSES 225 MR	55	2950	179	95.7	0.89	0.86	0.80	93.5	93.8	93.4	7.9	3.0	3.3	0.17	230	73
LSES 225 MG	90	2968	287	153	0.90	0.88	0.82	94.6	94.8	94.3	8.4	2.8	3.4	0.43	355	73
LSES 250 MF	105	2965	338	175	0.92	0.90	0.85	94.6	95.0	94.7	8.6	2.8	3.2	0.45	430	76
LSES 280 SU	160	2975	512	270	0.90	0.89	0.85	94.9	94.8	94.0	7.6	2.9	3.1	1.97	805	81

LSES high efficiency three-phase asynchronous motors



Selection

4
poles
1500 min⁻¹

IP 55 - 50 Hz - Class F - ΔT 80 K - 230 V Δ / 400 V Y and 400 V Δ - S1 - Class IE2

IE2

Type	Rated power P_N kW	Rated speed N_N min ⁻¹	Rated torque M_N N.m	Rated current $I_{N(400V)}$ A	Power factor			Efficiency IEC 60034-2-1 2007			Starting current/ Rated current I_d / I_n	Starting torque/ Rated torque M_d / M_n	Maximum torque/ Rated torque M_v / M_n	Moment of inertia J kg.m ²	Weight IM B3 kg	Noise LP db(A)
					$\cos \varphi$			η								
					4/4	3/4	2/4	4/4	3/4	2/4						
LS 56 M*	0.06	1380	0.4	0.29	0.76	0.69	0.62	41.8	37.1	29.7	2.8	2.4	2.5	0.00025	4	47
LS 56 M*	0.09	1400	0.6	0.39	0.60	0.52	0.42	55.2	49.6	42.8	3.2	2.8	2.8	0.00025	4	47
LS 63 M*	0.12	1380	0.8	0.44	0.70	0.58	0.47	56.1	53.9	46.8	3.2	2.4	2.3	0.00035	4.8	49
LS 63 M*	0.18	1390	1.2	0.64	0.65	0.55	0.44	61.6	58.0	51.3	3.7	2.6	2.6	0.00048	5	49
LS 71 M*	0.25	1425	1.7	0.80	0.65	0.55	0.44	69.4	66.8	59.8	4.6	2.7	2.9	0.00068	6.4	49
LS 71 M*	0.37	1420	2.5	1.06	0.70	0.59	0.47	72.1	71.7	66.4	4.9	2.4	2.8	0.00085	7.3	49
LS 71 L*	0.55	1400	3.8	1.62	0.70	0.62	0.49	70.4	70.0	65.1	4.8	2.3	2.5	0.0011	8.3	49
LS 80 L*	0.55	1410	3.7	1.42	0.76	0.68	0.55	73.2	69.1	62.1	4.5	2.0	2.3	0.0013	8.2	47
LSES 80 LG	0.75	1445	5.0	1.7	0.77	0.69	0.55	80.1	80.8	79.0	5.6	1.8	2.6	0.00261	11.7	47
LSES 90 S	1.1	1435	7.5	2.4	0.82	0.75	0.62	81.5	83.3	83.0	5.4	1.9	2.5	0.00298	12.2	48
LSES 90 L	1.5	1445	9.9	3.2	0.80	0.71	0.55	83.0	83.9	82.4	5.5	1.9	2.4	0.00374	14.6	48
LSES 100 L	2.2	1440	14.6	4.6	0.82	0.74	0.63	84.7	85.9	86.1	6.3	2.3	2.2	0.00531	21.3	48
LSES 100 LR	3	1439	19.9	6.5	0.78	0.72	0.58	85.5	86.7	86.4	7.1	3.0	4.1	0.00665	25.7	48
LSES 112 MU	4	1455	26.3	8.4	0.79	0.71	0.57	87.0	87.9	87.5	7.2	2.5	3.2	0.0129	35	49
LSES 132 SU	5.5	1455	35.9	11.9	0.76	0.67	0.53	87.7	88.4	87.5	7.2	2.6	3.7	0.0157	42	49
LSES 132 M	7.5	1458	48.6	14.6	0.83	0.76	0.63	88.9	89.8	89.3	8.0	2.9	3.9	0.0252	57	62
LSES 160 MR	11	1459	72.2	21.2	0.83	0.78	0.66	90.1	90.9	90.5	8.2	3.3	4.0	0.035	77	62
LSES 160 L	15	1457	97.9	28.2	0.84	0.80	0.69	90.8	91.8	92.1	7.4	2.2	3.1	0.07	91	62
LSES 180 MT	18.5	1458	121	35.1	0.83	0.78	0.66	91.4	92.1	92.1	7.6	2.9	3.6	0.08	103	64
LSES 180 LR	22	1458	144	41.0	0.84	0.79	0.67	91.8	92.5	92.5	7.8	2.8	3.3	0.09	115	64
LSES 200 LR	30	1463	196	56.5	0.83	0.78	0.67	92.4	92.9	92.5	7.0	2.8	2.8	0.16	164	69
LSES 225 ST	37	1469	240	69.7	0.82	0.78	0.68	92.9	93.7	93.8	6.3	2.7	2.7	0.23	205	64
LSES 225 MR	45	1471	292	84.1	0.83	0.79	0.68	93.3	93.9	93.8	6.9	2.3	2.4	0.29	235	64
LSES 250 ME	55	1482	355	102	0.84	0.79	0.69	94.1	94.4	93.9	7.4	2.6	2.7	0.65	328	69
LSES 280 SC	75	1482	483	139	0.83	0.78	0.67	94.5	94.6	94.0	8.8	2.4	2.9	0.86	392	70
LSES 280 MD	90	1481	582	166	0.83	0.78	0.68	94.6	94.8	94.3	7.9	3.4	3.7	1.03	455	69
LSES 315 SP	110	1488	706	204	0.82	0.78	0.67	94.5	94.1	92.8	7.9	3.1	3.4	2.32	670	76
LSES 315 MP	132	1486	855	238	0.85	0.81	0.72	95.4	95.2	94.3	7.9	3.1	3.4	2.79	758	70
LSES 315 MR	160	1484	1027	288	0.84	0.80	0.72	95.2	95.2	94.5	7.5	2.8	2.9	3.25	850	77
LSES 315 MR ¹	200	1484	1295	361	0.84	0.79	0.68	95.7	95.8	95.2	7.6	2.8	3.0	3.25	850	77

* Motors nonconcerned by IE2 1. Temperature rise class F

Non standards powers

Type	Rated power P_N kW	Rated speed N_N min ⁻¹	Rated torque M_N N.m	Rated current $I_{N(400V)}$ A	Power factor			Efficiency IEC 60034-2-1 2007			Starting current/ Rated current I_d / I_n	Starting torque/ Rated torque M_d / M_n	Maximum torque/ Rated torque M_v / M_n	Moment of inertia J kg.m ²	Weight IM B3 kg	Noise LP db(A)
					$\cos \varphi$			η								
					4/4	3/4	2/4	4/4	3/4	2/4						
LSES 80 LG	0.9	1437	6.0	2.1	0.83	0.74	0.60	80.0	81.7	80.0	5.5	1.9	2.5	0.00374	12.5	47
LSES 80 LG	1.1	1435	7.5	2.4	0.82	0.75	0.62	81.5	83.3	83.0	6.2	2.4	2.8	0.00374	12.7	47
LSES 90 LU	1.8	1442	12.4	3.8	0.81	0.72	0.57	83.9	84.4	82.8	6.6	2.6	2.3	0.0043	19	48
LSES 132 MU	9	1462	58.9	17.4	0.83	0.77	0.66	89.8	90.5	89.9	8.0	3.3	3.7	0.0293	68	62
LSES 160 LU	18.5	1458	121	35.1	0.83	0.78	0.66	91.4	92.1	92.1	7.6	2.9	3.6	0.08	98	62
LSES 180 LUR	30	1463	196	56.5	0.83	0.78	0.67	92.4	92.9	92.5	7.0	2.8	2.8	0.16	160	69
LSES 225 MG	70	1482	451	127	0.84	0.79	0.68	94.4	94.4	93.6	8.8	2.0	2.9	0.85	380	69
LSES 280 SU	145	1487	937	261	0.84	0.79	0.69	95.4	95.1	93.9	9.0	3.3	3.4	3.11	800	70

LSES high efficiency three-phase asynchronous motors



Selection

6
poles
1000 min⁻¹

IP 55 - 50 Hz - Class F - ΔT 80 K - 230 V Δ / 400 V Y and 400 V Δ - S1 - Class IE2

IE2

Type	Rated power	Rated speed	Rated torque	Rated current	Power factor			Efficiency IEC 60034-2-1 2007			Starting current/ Rated current	Starting torque/ Rated torque	Maximum torque/ Rated torque	Moment of inertia	Weight	Noise
	P_N	N_N	M_N	$I_{N(400V)}$	Cos φ			η			I_d / I_n	M_d / M_n	M_v / M_n	J	IMB3	LP
	kW	min ⁻¹	N.m	A	4/4	3/4	2/4	4/4	3/4	2/4				kg.m ²	kg	db(A)
LS 56 M*	0.045	860	0.5	0.29	0.66	0.59	0.52	34	31.5	25.3	2	1.7	1.7	0.00025	4	54
LS 56 M*	0.06	850	0.7	0.39	0.67	0.60	0.53	33.4	30.9	25	2	1.7	1.7	0.00025	4	54
LS 63 M*	0.09	860	1.0	0.46	0.80	0.70	0.63	35	32	26	2.1	1.6	1.6	0.0006	5.5	48
LS 71 M*	0.12	950	1.2	0.75	0.51	0.44	0.38	45.6	40.5	32	3	2.4	3.0	0.0007	6.5	52
LS 71 M*	0.18	945	1.8	0.95	0.52	0.46	0.38	52.8	48.8	40.7	3.3	2.3	2.9	0.0011	7.6	52
LS 71 L*	0.25	915	2.6	1.15	0.60	0.52	0.43	51.9	49.6	42.2	3.1	2.0	2.2	0.0013	7.9	52
LS 80 L*	0.25	955	2.5	0.85	0.67	0.64	0.48	62.8	62.7	56	3.9	1.6	1.8	0.0024	8.4	41
LS 80 L*	0.37	950	3.7	1.1	0.72	0.67	0.57	65.8	59.7	59	4.3	1.7	2.2	0.0032	9.7	41
LS 80 L*	0.55	950	5.5	1.8	0.64	0.60	0.47	68	63	55	4.9	2.1	2.6	0.0042	11	41
LSES 90 S	0.75	953	7.6	2.1	0.68	0.59	0.46	76.6	77.1	74.4	4.1	1.6	2.1	0.00319	14	51
LSES 90 L	1.1	955	11.0	3.0	0.67	0.58	0.45	79.1	79.5	77.4	4.8	2.0	3.1	0.0044	16.6	51
LSES 100 L	1.5	957	14.9	4.0	0.66	0.58	0.45	80.5	81.1	79.0	4.7	2.0	2.2	0.00587	22.1	50
LSES 112 MG	2.2	957	20.9	5.0	0.73	0.65	0.51	82.2	83.3	82.0	5.3	1.6	2.4	0.011	28	51
LSES 132 S	3	962	29.1	7.0	0.72	0.64	0.50	83.8	84.5	83.1	6.2	2.2	3.1	0.0154	38	55
LSES 132 M	4	963	39.4	9.0	0.75	0.68	0.56	85.2	86.7	86.4	5.7	2.0	2.6	0.0249	48	55
LSES 132 MU	5.5	963	55.0	12.9	0.72	0.66	0.54	86.4	87.4	86.9	5.6	2.5	2.8	0.0364	63	55
LSES 160 M	7.5	970	73.3	15.5	0.80	0.76	0.65	87.2	88.3	88.3	5.0	1.4	2.1	0.09	82	56
LSES 160 LU	11	970	108	23.0	0.79	0.74	0.62	88.7	89.3	88.9	5.4	1.7	2.5	0.13	98	56
LSES 180 L	15	973	148	30.1	0.80	0.74	0.63	90.0	90.9	90.7	6.9	2.5	3.1	0.19	134	60
LSES 200 LR	18.5	973	182	36.6	0.81	0.76	0.66	90.5	91.5	91.6	6.9	2.4	2.8	0.25	165	63
LSES 200 L	22	975	215	43.6	0.80	0.75	0.65	91.3	92.0	91.9	6.8	2.3	2.9	0.3	187	62
LSES 225 MR	30	977	293	62.5	0.75	0.70	0.59	91.8	92.2	91.6	7.2	2.8	3.1	0.4	234	63
LSES 250 ME	37	983	358	67.8	0.85	0.81	0.72	92.7	93.1	92.6	6.0	2.0	2.3	0.72	286	65
LSES 280 SC	45	982	439	85.5	0.82	0.78	0.67	93.0	93.5	93.3	6.1	2.0	2.5	0.83	312	65
LSES 280 MC	55	982	536	103	0.82	0.78	0.67	93.4	93.7	93.1	6.5	2.4	2.8	1.03	354	65
LSES 315 SN	75	982	729	136	0.85	0.82	0.74	93.7	94.3	94.1	6.5	2.4	2.5	1.4	460	65
LSES 315 MP	90	986	872	168	0.82	0.79	0.71	94.1	94.5	94.2	6.0	1.8	2.4	2.93	642	69
LSES 315 MP	110	988	1062	209	0.80	0.76	0.66	94.6	94.8	94.1	6.5	2.4	2.6	3.54	718	74
LSES 315 MR	132	987	1278	248	0.81	0.77	0.67	94.7	95.0	94.7	6.6	2.5	2.5	4.2	840	68

* Motors nonconcerned by IE2

Non standards powers

Type	Rated power	Rated speed	Rated torque	Rated current	Power factor			Efficiency IEC 60034-2-1 2007			Starting current/ Rated current	Starting torque/ Rated torque	Maximum torque/ Rated torque	Moment of inertia	Weight	Noise
	P_N	N_N	M_N	$I_{N(400V)}$	Cos φ			η			I_d / I_n	M_d / M_n	M_v / M_n	J	IMB3	LP
	kW	min ⁻¹	N.m	A	4/4	3/4	2/4	4/4	3/4	2/4				kg.m ²	kg	db(A)
LSES 180 LUR	18.5	973	182	36.6	0.81	0.76	0.66	90.5	91.5	91.6	6.9	2.4	2.8	0.25	162	60
LSES 200 LU	27	978	263	55.0	0.77	0.76	0.60	91.6	91.6	90.7	6.7	2.6	2.8	0.39	220	63
LSES 225 MG	45	982	439	85.5	0.82	0.78	0.67	93.0	93.5	93.3	6.1	2.0	2.5	0.83	300	63
LSES 280 SK	100	988	966	195	0.79	0.73	0.60	94.5	94.4	93.5	6.6	2.4	2.8	3.27	650	65

LSES high efficiency three-phase asynchronous motors



Dimensions

LSES totally enclosed three-phase asynchronous motors dimensions - IP 55
Cage rotor

Dimensions in millimetres

- shaft end

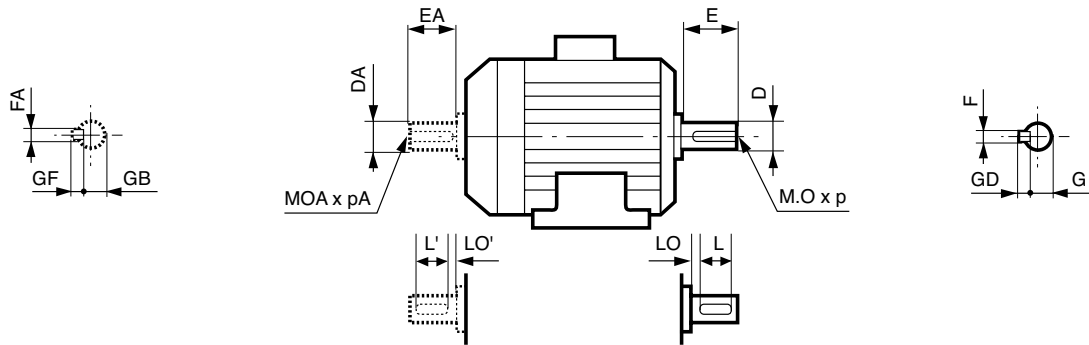

Type	Main shaft end																	
	4 and 6 poles									2 poles								
	F	GD	D	G	E	O	p	L	LO	F	GD	D	G	E	O	p	L	LO
LSES 80L/LG	6	6	19j6	15.5	40	6	16	30	6	6	6	19j6	15.5	40	6	16	30	6
LSES 90S/L	8	7	24j6	20	50	8	19	40	6	8	7	24j6	20	50	8	19	40	6
LSES 100L/LR	8	7	28j6	24	60	10	22	50	6	8	7	28j6	24	60	10	22	50	6
LSES 112MR/MG/MU	8	7	28j6	24	60	10	22	50	6	8	7	28j6	24	60	10	22	50	6
LSES 132S/SU/M/MU	10	8	38k6	33	80	12	28	63	10	10	8	38k6	33	80	12	28	63	10
LSES 160MP/MR/LR/M/L/LU	12	8	42k6	37	110	16	36	100	6	12	8	42k6	37	110	16	36	100	6
LSES 180MT/L/LR	14	9	48k6	42.5	110	16	36	98	12	14	9	48k6	42.5	110	16	36	98	12
LSES 200L/LR	16	10	55m6	49	110	20	42	97	13	16	10	55m6	49	110	20	42	97	13
LSES 225ST/MR/MT	18	11	60m6	53	140	20	42	126	14	18	11	60m6	53	140	20	42	97	13
LSES 250ME/MZ	18	11	65m6	58	140	20	42	126	14	18	11	60m6	53	140	20	42	126	14
LSES 280SC/MC/MD	20	12	75m6	67.5	140	20	42	125	15	18	11	65m6	58	140	20	42	125	14
LSES 315SN/SP/MP/MR	22	14	80m6	71	170	20	42	155	15	18	11	65m6	58	140	20	42	126	14

Type	Secondary shaft end																	
	4 and 6 poles									2 poles								
	FA	GF	DA	GB	EA	OA	pA	L'	LO'	FA	GF	DA	GB	EA	OA	pA	L'	LO'
LSES 80L/LG	5	5	14j6	11	30	5	15	25	3.5	5	5	14j6	11	30	5	15	25	3.5
LSES 90S/L	6	6	19j6	15.5	40	6	16	30	6	6	6	19j6	15.5	40	6	16	30	6
LSES 100L/LR	8	7	24j6	20	50	8	19	40	6	8	7	24j6	20	50	8	19	40	6
LSES 112MR/MG/MU	8	7	24j6	20	50	8	19	40	6	8	7	24j6	20	50	8	19	40	6
LSES 132S/SU/M/MU	8	7	28k6	24	60	10	22	50	6	8	7	28k6	24	60	10	22	50	6
LSES 160MP/MR/LR	12	8	38k6	37	80	16	36	100	6	12	8	38k6	37	80	16	36	100	6
LSES 160M/L/LU	12	8	42k6	37	110	16	36	100	6	12	8	42k6	37	110	16	36	100	6
LSES 180MT/L/LR	14	9	48k6	42.5	110	16	36	98	12	14	9	48k6	42.5	110	16	36	98	12
LSES 200L/LR	16	10	55m6	49	110	20	42	97	13	16	10	55m6	49	110	20	42	97	13
LSES 225ST/MR/MT	18	11	60m6	53	140	20	42	126	14	18	11	60m6	53	140	20	42	97	13
LSES 250ME/MZ	18	11	60m6	53	140	20	42	126	14	18	11	60m6	53	140	20	42	126	14
LSES 280SC/MC/MD	18	11	65m6	58	140	20	42	126	14	18	11	65m6	58	140	20	42	126	14
LSES 315SN	20	12	75m6	67.5	140	20	42	125	15	18	11	65m6	58	140	20	42	125	14
LSES 315SP/MP/MR	22	14	80m6	71	170	24	42	155	15	18	11	65m6	58	140	20	42	126	14

LSES high efficiency three-phase asynchronous motors



Dimensions

LSES totally enclosed three-phase asynchronous motors dimensions - IP 55 Cage rotor

Dimensions in millimetres

- foot mounted

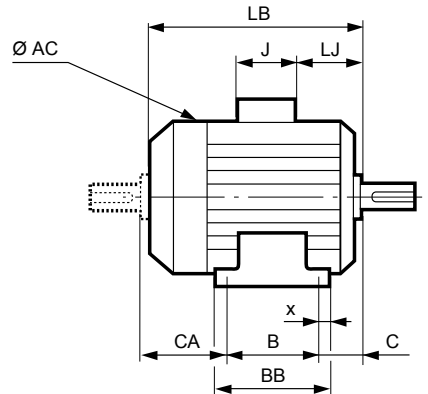
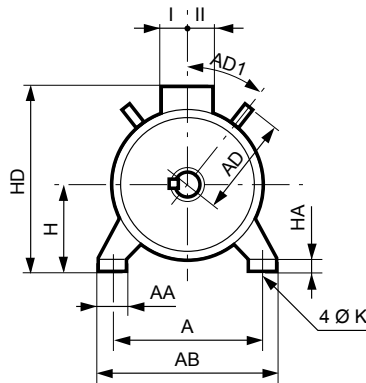

Type	Mains dimensions																				
	A	AB	B	BB	C	X	AA	K	HA	H	AC*	HD	LB	LB1**	LJ	J	I	II	AD	AD1	CA
LSES 80 L	125	157	100	120	50	10	29	10	10	80	170	205	215	177	25.5	86	43	43	-	-	68
LSES 80 LG	125	157	100	125	50	14	31	10	10	80	185	215	247	204	25.5	86	43	43	-	-	99
LSES 90 S	140	172	100	120	56	10	37	10	11	90	190	225	217.5	177	25.5	86	43	43	-	-	66
LSES 90 L	140	172	125	162	56	28	39	10	11	90	190	225	244.5	204	25.5	86	43	43	-	-	68
LSES 100 L	160	196	140	165	63	12	40	12	13	100	200	240	290	250	26.5	86	43	43	118	45	93
LSES 100 LR	160	196	140	165	63	12	40	12	13	100	200	240	309	264	26.5	86	43	43	118	45	111
LSES 112 MR	190	220	140	165	69	13	45	12	14	112	200	252	309	264	26.5	86	43	43	118	45	104
LSES 112 MU	190	220	140	165	70	12	52	12	14	112	235	261	333	288	35.5	86	43	43	-	-	130
LSES 112 MG	190	220	140	165	70	12	52	12	14	112	235	261	315	265	35.5	86	43	43	-	-	110
LSES 132 S	216	250	140	170	89	16	42	12	16	132	220	304	350	306	32.5	126	63	63	130	45	128
LSES 132 SU	216	250	140	170	89	16	42	12	16	132	220	304	377	329	32.5	126	63	63	130	45	152
LSES 132 M	216	250	178	208	89	15	50	12	15	132	265	322	385	327	17	126	63	63	140	45	126
LSES 132 MU	216	250	178	208	89	15	50	12	15	132	265	322	412	351	17	126	63	63	140	45	148
LSES 160 MP	254	294	210	294	108	20	64	14.5	25	160	264	350	468	407	58.5	126	63	63	155	45	154
LSES 160 MR	254	294	210	294	108	20	64	14.5	25	160	264	350	495	440	58.5	126	63	63	155	45	138
LSES 160 M	254	294	254	294	108	20	60	14.5	25	160	312	395	495	435	42.75	135	88	64	-	-	182
LSES 160 L	254	294	254	294	108	20	60	14.5	25	160	312	395	495	435	42.75	135	88	64	-	-	138
LSES 160 LU	254	294	254	294	108	20	60	14.5	25	160	312	395	510	450	42.75	135	88	64	-	-	153
LSES 180 MT	279	324	241	316	121	20	79	14.5	28	180	312	428	495	435	54.75	186	112	98	-	-	138
LSES 180 LR	279	324	279	316	121	20	79	14.5	28	180	312	428	520	450	54.75	186	112	98	-	-	125
LSES 180 L	279	339	279	329	121	25	86	14.5	25	180	350	436	552	481	63.5	186	112	98	-	-	159
LSES 200 LR	318	378	305	365	133	30	108	18.5	30	200	350	456	620	539	69.5	186	112	98	-	-	194
LSES 200 L	318	388	305	375	133	35	103	18.5	36	200	390	476	621	539	77	186	112	98	-	-	194
LSES 200 LU	318	388	305	375	133	35	103	18.5	36	200	390	476	669	587	77	186	112	98	-	-	194
LSES 225 ST	356	431	286	386	149	50	127	18.5	36	225	390	535	627.5	545	61	231	119	142	-	-	203
LSES 225 MT	356	431	311	386	149	50	127	18.5	36	225	390	535	627.5	545	61	231	119	142	-	-	178
LSES 225 MR	356	431	311	386	149	50	127	18.5	36	225	390	535	675.5	593	61	231	119	142	-	-	228
LSES 225 MG	356	420	311	375	142	30	65	18.5	30	225	479	630	810	727.5	68	292	151	181	-	-	360
LSES 250 MZ	406	470	349	449	167.5	70	150	24	47	250	390	560	675.5	593	61	231	119	142	-	-	171
LSES 250 ME	406	470	349	420	168	35	90	24	36	250	479	656	810	716	67.5	292	151	181	-	-	303
LSES 250 MF	406	470	349	420	168	35	90	24	36	250	479	656	870	776	67.5	292	151	181	-	-	353
LSES 280 MC	457	520	419	478	190	35	90	24	35	280	479	686	810	716	67.5	292	151	181	-	-	211
LSES 280 SC	457	520	368	478	190	35	90	24	35	280	479	686	810	716	67.5	292	151	181	-	-	262
LSES 280 SK	457	533	368	495	190	40	85	24	35	280	586	746	921	827	99	292	151	181	-	-	312
LSES 280 SU	457	533	368	495	190	40	85	24	35	280	586	746	991	897	99	292	151	181	-	-	382
LSES 280 MD	457	520	419	478	190	35	90	24	35	280	479	686	870	870	67.5	292	151	181	-	-	271
LSES 315 SN	508	594	406	537	216	40	140	28	50	315	479	805	870	776	4.5	418	180	236	-	-	248
LSES 315 MP	508	594	457	537	216	40	114	28	70	315	586	865	947	845	61.5	418	180	236	-	-	290
LSES 315 MR	508	594	457	537	216	40	114	28	70	315	586	865	1017	947	61.5	418	180	236	-	-	360
LSES 315 SP	508	594	406	537	216	40	114	28	70	315	586	865	947	845	61.5	418	180	236	-	-	341

* AC : housing diameter without ring of lifting.

** LB1 : motor not ventilated.

LSES high efficiency three-phase asynchronous motors



Dimensions

LSES totally enclosed three-phase asynchronous motors dimensions - IP 55 Cage rotor

Dimensions in millimetres

– (FF) foot and plain hole flange mounted

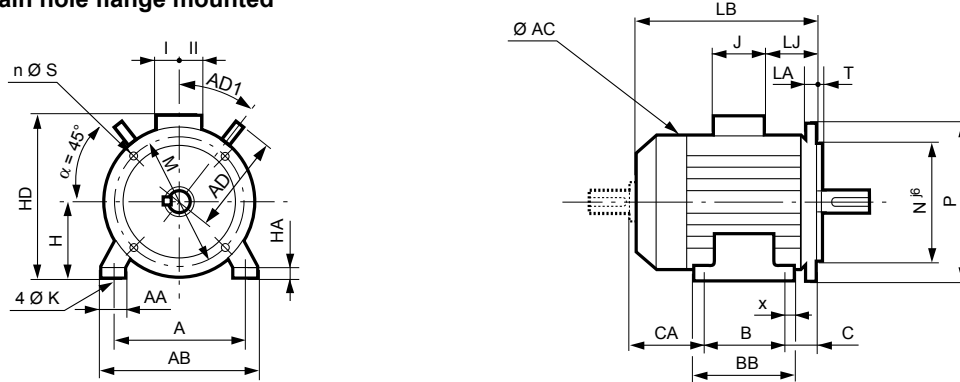

Type	Main dimensions																					
	A	AB	B	BB	C	X	AA	K	HA	H	AC*	HD	LB	LB1**	LJ	J	I	II	AD	AD1	CA	Symb
LSES 80 L	125	157	100	120	50	10	29	10	10	80	170	205	215	177	25.5	86	43	43	-	-	68	FF 165
LSES 80 LG	125	157	100	125	70	14	31	10	10	80	185	215	267	224	46	86	43	43	-	-	99	FF 165
LSES 90 S	140	172	100	120	76	10	37	10	11	90	190	225	237	196.5	46	86	43	43	-	-	66	FF 165
LSES 90 L	140	172	125	162	76	28	39	10	11	90	190	225	265	224.5	46	86	43	43	-	-	68	FF 165
LSES 100 L	160	196	140	165	63	12	40	12	13	100	200	240	290	250	26.5	86	43	43	118	45	93	FF 215
LSES 100 LR	160	196	140	165	63	12	40	12	13	100	200	240	309	264	26.5	86	43	43	118	45	111	FF 215
LSES 112 MR	190	220	140	165	69	13	45	12	14	112	200	252	309	264	26.5	86	43	43	118	45	104	FF 215
LSES 112 MU	190	220	140	165	70	12	52	12	14	112	235	261	333	288	35.5	86	43	43	-	-	130	FF 215
LSES 112 MG	190	220	140	165	70	12	52	12	14	112	235	261	315	265	35.5	86	43	43	-	-	110	FF 215
LSES 132 S	216	250	140	170	89	16	42	12	16	132	220	304	350	306	32.5	126	63	63	130	45	128	FF 265
LSES 132 SU	216	250	140	170	89	16	42	12	16	132	220	304	377	329	32.5	126	63	63	130	45	152	FF 265
LSES 132 M	216	250	178	208	89	15	50	12	15	132	265	322	385	327	17	126	63	63	140	45	126	FF 265
LSES 132 MU	216	250	178	208	89	15	50	12	15	132	265	322	412	351	17	126	63	63	140	45	148	FF 265
LSES 160 MP	254	294	210	294	108	20	64	14.5	25	160	264	350	468	407	58.5	126	63	63	155	45	154	FF 300
LSES 160 MR	254	294	210	294	108	20	64	14.5	25	160	264	350	495	440	58.5	126	63	63	155	45	138	FF 300
LSES 160 M	254	294	254	294	108	20	60	14.5	25	160	312	395	495	435	42.75	135	88	64	-	-	182	FF 300
LSES 160 L	254	294	254	294	108	20	60	14.5	25	160	312	395	495	435	42.75	135	88	64	-	-	138	FF 300
LSES 160 LU	254	294	254	294	108	20	60	14.5	25	160	312	395	510	450	42.75	135	88	64	-	-	153	FF 300
LSES 180 MT	279	324	241	316	121	20	79	14.5	28	180	312	428	495	435	54.75	186	112	98	-	-	138	FF 300
LSES 180 LR	279	324	279	316	121	20	79	14.5	28	180	312	428	520	450	54.75	186	112	98	-	-	125	FF 300
LSES 180 L	279	339	279	329	121	25	86	14.5	25	180	350	436	552	481	63.5	186	112	98	-	-	159	FF 300
LSES 200 LR	318	378	305	365	133	30	108	18.5	30	200	350	456	620	539	69.5	186	112	98	-	-	194	FF 350
LSES 200 L	318	388	305	375	133	35	103	18.5	36	200	390	476	621	539	77	186	112	98	-	-	194	FF 350
LSES 200 LU	318	388	305	375	133	35	103	18.5	36	200	390	476	669	587	77	186	112	98	-	-	194	FF 350
LSES 225 ST	356	431	286	386	149	50	127	18.5	36	225	390	535	627.5	545	61	231	119	142	-	-	203	FF 400
LSES 225 MT	356	431	311	386	149	50	127	18.5	36	225	390	535	627.5	545	61	231	119	142	-	-	178	FF 400
LSES 225 MR	356	431	311	386	149	50	127	18.5	36	225	390	535	675.5	593	61	231	119	142	-	-	228	FF 400
LSES 225 MG	356	420	311	375	142	30	65	18.5	30	225	479	630	810	727.5	68	292	151	181	-	-	360	FF 400
LSES 250 MZ	406	470	349	449	167.5	70	150	24	47	250	390	560	675.5	593	61	231	119	142	-	-	171	FF 500
LSES 250 ME	406	470	349	420	168	35	90	24	36	250	479	656	810	716	67.5	292	151	181	-	-	303	FF 500
LSES 250 MF	406	470	349	420	168	35	90	24	36	250	479	656	870	776	67.5	292	151	181	-	-	353	FF 500
LSES 280 MC	457	520	419	478	190	35	90	24	35	280	479	686	810	716	67.5	292	151	181	-	-	211	FF 500
LSES 280 SC	457	520	368	478	190	35	90	24	35	280	479	686	810	716	67.5	292	151	181	-	-	262	FF 500
LSES 280 SK	457	533	368	495	190	40	85	24	35	280	586	746	921	827	99	292	151	181	-	-	312	FF 500
LSES 280 SU	457	533	368	495	190	40	85	24	35	280	586	746	991	897	99	292	151	181	-	-	382	FF 500
LSES 280 MD	457	520	419	478	190	35	90	24	35	280	479	686	870	870	67.5	292	151	181	-	-	271	FF 500
LSES 315 SN	508	594	406	537	216	40	140	28	50	315	479	805	870	776	4.5	418	180	236	-	-	248	FF 600
LSES 315 MP	508	594	457	537	216	40	114	28	70	315	586	865	947	845	61.5	418	180	236	-	-	290	FF 600
LSES 315 MR	508	594	457	537	216	40	114	28	70	315	586	865	1017	947	61.5	418	180	236	-	-	360	FF 600
LSES 315 SP	508	594	406	537	216	40	114	28	70	315	586	865	947	845	61.5	418	180	236	-	-	341	FF 600

* AC : housing diameter without ring of lifting.

** LB1 : motor not ventilated.

LSES high efficiency three-phase asynchronous motors



Dimensions

LSES totally enclosed three-phase asynchronous motors dimensions - IP 55 Cage rotor

Dimensions in millimetres

– (FF) plain hole flange mounted

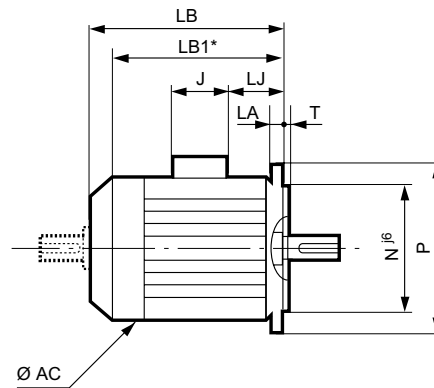
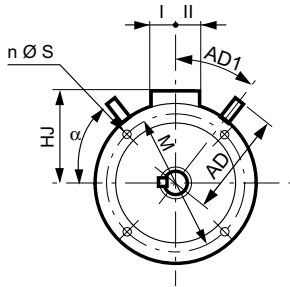

IEC symbol	Flange dimensions							
	M	N	P	T	n	α°	S	LA
FF 165	165	130	200	3.5	4	45	12	10
FF 165	165	130	200	3.5	4	45	12	10
FF 165	165	130	200	3.5	4	45	12	10
FF 165	165	130	200	3.5	4	45	12	10
FF 215	215	180	250	4	4	45	14.5	12
FF 215	215	180	250	4	4	45	14.5	12
FF 215	215	180	250	4	4	45	14.5	11
FF 215	215	180	250	4	4	45	14.5	11
FF 215	215	180	250	4	4	45	14.5	11
FF 265	265	230	300	4	4	45	14.5	12
FF 265	265	230	300	4	4	45	14.5	12
FF 265	265	230	300	4	4	45	14.5	12
FF 265	265	230	300	4	4	45	14.5	12
FF 300	300	250	350	5	4	45	18.5	14
FF 300	300	250	350	5	4	45	18.5	14
FF 300	300	250	350	5	4	45	18.5	14
FF 300	300	250	350	5	4	45	18.5	14
FF 300	300	250	350	5	4	45	18.5	14
FF 300	300	250	350	5	4	45	18.5	14
FF 300	300	250	350	5	4	45	18.5	14
FF 350	350	300	400	5	4	45	18.5	15
FF 350	350	300	400	5	4	45	18.5	15
FF 350	350	300	400	5	4	45	18.5	15
FF 400	400	350	450	5	8	22.5	18.5	16
FF 400	400	350	450	5	8	22.5	18.5	16
FF 400	400	350	450	5	8	22.5	18.5	16
FF 400	400	350	450	5	8	22.5	18.5	16
FF 500	500	450	550	5	8	22.5	18.5	18
FF 500	500	450	550	5	8	22.5	18.5	18
FF 500	500	450	550	5	8	22.5	18.5	18
FF 500	500	450	550	5	8	22.5	18.5	18
FF 500	500	450	550	5	8	22.5	18.5	18
FF 500	500	450	550	5	8	22.5	18.5	18
FF 500	500	450	550	5	8	22.5	18.5	18
FF 600	600	550	660	6	8	22.5	24	22
FF 600	600	550	660	6	8	22.5	24	22
FF 600	600	550	660	6	8	22.5	24	22
FF 600	600	550	660	6	8	22.5	24	22

Type	Main dimensions												
	AC*	LB	LB1**	HJ	LJ	J	I	II	AD	AD1			
LSES 80 L	170	215	177	125	25.5	86	43	43	-	-			
LSES 80 LG	185	267	224	135	46	86	43	43	-	-			
LSES 90 S	190	237	196.5	135	46	86	43	43	-	-			
LSES 90 L	190	265	224.5	135	46	86	43	43	-	-			
LSES 100 L	200	290	250	140	26.5	86	43	43	118	45			
LSES 100 LR	200	309	264	140	26.5	86	43	43	118	45			
LSES 112 MR	200	309	264	140	26.5	86	43	43	118	45			
LSES 112 MU	235	333	288	149	35.5	86	43	43	-	-			
LSES 112 MG	235	315	265	149	35.5	86	43	43	-	-			
LSES 132 S	220	350	306	172	32.5	126	63	63	130	45			
LSES 132 SU	220	377	329	172	32.5	126	63	63	130	45			
LSES 132 M	265	385	327	190	17	126	63	63	140	45			
LSES 132 MU	265	412	351	190	17	126	63	63	140	45			
LSES 160 MP	264	468	407	190	58.5	126	63	63	155	45			
LSES 160 MR	264	495	440	190	58.5	126	63	63	155	45			
LSES 160 M	312	495	435	235	42.75	135	88	64	-	-			
LSES 160 L	312	495	435	235	42.75	135	88	64	-	-			
LSES 160 LU	312	510	450	235	42.75	135	88	64	-	-			
LSES 180 MT	312	495	435	248	54.75	186	112	98	-	-			
LSES 180 LR	312	520	450	248	54.75	186	112	98	-	-			
LSES 180 L	350	552	481	256	63.5	186	112	98	-	-			
LSES 200 LR	350	620	539	256	69.5	186	112	98	-	-			
LSES 200 L	390	621	539	276	77	186	112	98	-	-			
LSES 200 LU	390	669	587	276	77	186	112	98	-	-			
LSES 225 ST	390	627.5	545	310	61	231	119	142	-	-			
LSES 225 MT	390	627.5	545	310	61	231	119	142	-	-			
LSES 225 MR	390	675.5	593	310	61	231	119	142	-	-			
LSES 225 MG	479	810	727.5	405	68	292	151	181	-	-			
LSES 250 MZ	390	675.5	593	310	61	231	119	142	-	-			
LSES 250 ME	479	810	716	406	67.5	292	151	181	-	-			
LSES 250 MF	479	870	776	406	67.5	292	151	181	-	-			
LSES 280 MC	479	810	716	406	67.5	292	151	181	-	-			
LSES 280 SC	479	810	716	406	67.5	292	151	181	-	-			
LSES 280 SK	586	921	827	466	99	292	151	181	-	-			
LSES 280 SU	586	991	897	466	99	292	151	181	-	-			
LSES 280 MD	479	870	870	406	67.5	292	151	181	-	-			
LSES 315 SN	479	870	776	490	4.5	418	180	236	-	-			
LSES 315 MP	586	947	845	550	61.5	418	180	236	-	-			
LSES 315 MR	586	1017	947	550	61.5	418	180	236	-	-			
LSES 315 SP	586	947	845	550	61.5	418	180	236	-	-			

* AC : housing diameter without ring of lifting

** LB1 : motor not ventilated

For IM 3001 use, for frame size ≥ 250mm, consult us.

Shaft end dimensions identical to those of the foot mounted motors.

LSES high efficiency three-phase asynchronous motors



Dimensions

LSES totally enclosed three-phase asynchronous motors dimensions - IP 55 Cage rotor

Dimensions in millimetres

– (FT) foot and tapped hole flange mounted motor

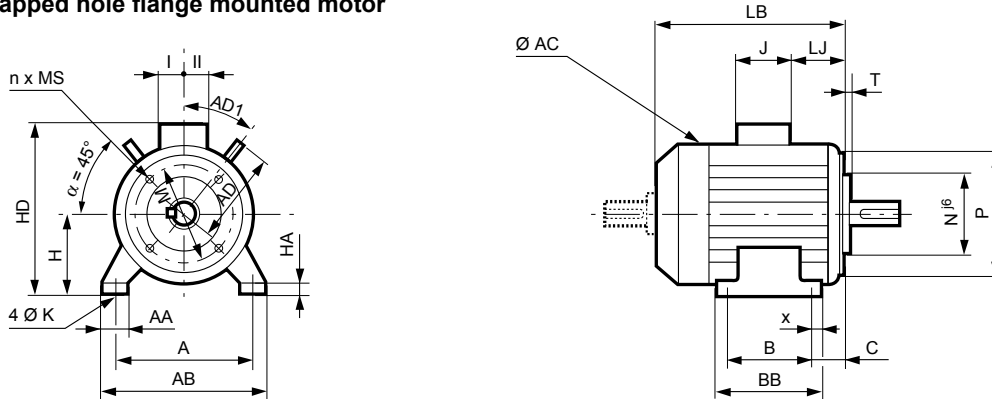

Main dimensions

Type	A	AB	B	BB	C	X	AA	K	HA	H	AC*	HD	LB	LB1**	LJ	J	I	II	AD	AD1	CA	Symb
LSES 80 L	125	157	100	120	50	10	29	10	10	80	170	205	215	177	25.5	86	43	43	-	-	68	FT 100
LSES 80 LG	125	157	100	125	50	14	31	10	10	80	185	215	247	204	25.5	86	43	43	-	-	99	FT 100
LSES 90 S	140	172	100	120	56	10	37	10	11	90	190	225	217.5	177	25.5	86	43	43	-	-	66	FT 115
LSES 90 L	140	172	125	162	56	28	39	10	11	90	190	225	244.5	204	25.5	86	43	43	-	-	68	FT 115
LSES 100 L	160	196	140	165	63	12	40	12	13	100	200	240	290	250	26.5	86	43	43	118	45	93	FT 130
LSES 100 LR	160	196	140	165	63	12	40	12	13	100	200	240	309	264	26.5	86	43	43	118	45	111	FT 130
LSES 112 MR	190	220	140	165	69	13	45	12	14	112	200	252	309	264	26.5	86	43	43	118	45	104	FT 130
LSES 112 MU	190	220	140	165	70	12	52	12	14	112	235	261	333	288	35.5	86	43	43	-	-	130	FT 130
LSES 112 MG	190	220	140	165	70	12	52	12	14	112	235	261	315	265	35.5	86	43	43	-	-	110	FT 130
LSES 132 S	216	250	140	170	89	16	42	12	16	132	220	304	350	306	32.5	126	63	63	130	45	128	FT 215
LSES 132 SU	216	250	140	170	89	16	42	12	16	132	220	304	377	329	32.5	126	63	63	130	45	152	FT 215
LSES 132 M	216	250	178	208	89	15	50	12	15	132	265	322	385	327	17	126	63	63	140	45	126	FT 215
LSES 132 MU	216	250	178	208	89	15	50	12	15	132	265	322	412	351	17	126	63	63	140	45	148	FT 215
LSES 160 MP	254	294	210	294	108	20	64	14.5	25	160	264	350	468	407	58.5	126	63	63	155	45	154	FT 215
LSES 160 MR	254	294	210	294	108	20	64	14.5	25	160	264	350	495	440	58.5	126	63	63	155	45	138	FT 215

* AC : housing diameter without ring of lifting

** LB1 : motor not ventilated

LSES high efficiency three-phase asynchronous motors



Dimensions

LSES totally enclosed three-phase asynchronous motors dimensions - IP 55
Cage rotor

Dimensions in millimetres

– (FT) tapped hole flange mounted

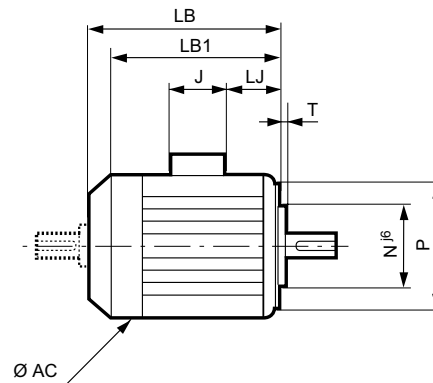
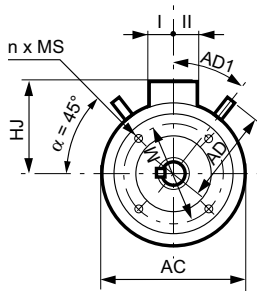

IEC symbol	Flange dimensions					
	M	N	P	T	n	MS
FT 100	100	80	120	3	4	M6
FT 100	100	80	120	3	4	M6
FT 115	115	95	140	3	4	M8
FT 115	115	95	140	3	4	M8
FT 130	130	110	160	3.5	4	M8
FT 130	130	110	160	3.5	4	M8
FT 130	130	110	160	3.5	4	M8
FT 130	130	110	160	3.5	4	M8
FT 215	215	180	250	4	4	M12
FT 215	215	180	250	4	4	M12
FT 215	215	180	250	4	4	M12
FT 215	215	180	250	4	4	M12
FT 215	215	180	250	4	4	M12
FT 215	215	180	250	4	4	M12

Type	Main dimensions									
	AC*	LB	LB1**	HJ	LJ	J	I	II	AD	AD1
LSES 80 L	170	215	177	125	25.5	86	43	43	-	-
LSES 80 LG	185	247	204	135	25.5	86	43	43	-	-
LSES 90 S	190	217.5	177	135	25.5	86	43	43	-	-
LSES 90 L	190	244.5	204	135	25.5	86	43	43	-	-
LSES 100 L	200	290	250	140	26.5	86	43	43	118	45
LSES 100 LR	200	309	264	140	26.5	86	43	43	118	45
LSES 112 MR	200	309	264	140	26.5	86	43	43	118	45
LSES 112 MG	235	333	288	149	35.5	86	43	43	-	-
LSES 112 MU	235	315	265	149	35.5	86	43	43	-	-
LSES 132 S	220	350	306	172	32.5	126	63	63	130	45
LSES 132 SU	220	377	329	172	32.5	126	63	63	130	45
LSES 132 M	265	385	327	190	17	126	63	63	140	45
LSES 132 MU	265	412	351	190	17	126	63	63	140	45
LSES 160 MP	264	468	407	190	58.5	126	63	63	155	45
LSES 160 MR/LR	264	495	440	190	58.5	126	63	63	155	45

* AC : housing diameter without ring of lifting

** LB1 : motor not ventilated

LSES high efficiency three-phase asynchronous motors



Lead times

2 poles
3000 min⁻¹

IP 55 - 50 Hz - Class F - ΔT 80 K - 230 V Δ / 400 V Y - S1 - Class IE2

Type	Rated power at 50 Hz P_N kW	IM 1001 (IM B3)		IM 3001' (IM B5)		IM 2001' (IM B35)		IM 3601' (IM B14)		IM 2101' (IM B34)	
		Code	Qty	Code	Qty	Code	Qty	Code	Qty	Code	Qty
LS 56 M	0.09	MA2 09 107	10	MA2 09 109	10	MA2 09 1C9	5	MA2 09 111	10	MA2 09 1D1	5
LS 56 M	0.12	MA2 12 107	10	MA2 12 109	5	MA2 12 1C9	5	MA2 12 111	5	MA2 21 1D1	5
LS 63 M	0.18	MA2 18 113	10	MA2 18 115	10	MA2 18 1C5	5	MA2 18 117	5	MA2 18 1D7	5
LS 63 M*	0.18	MA2 18 BA1	10	MA2 18 BA2	5	MA2 18 BA4	5	MA2 18 BA3	5	MA2 18 BA5	5
LS 63 M	0.25	MA2 25 125	10	MA2 25 127	10	MA2 25 1C7	5	MA2 25 129	10	MA2 25 1D9	5
LS 63 M*	0.25	MA2 25 BA1	10	MA2 25 BA2	5	MA2 25 BA4	5	MA2 25 BA3	10	MA2 25 BA5	5
LS 71 L	0.37	MA2 37 119	10	MA2 37 121	10	MA2 37 1C1	5	MA2 37 123	10	MA2 37 1D3	5
LS 71 L	0.55	MA2 55 119	10	MA2 55 121	10	MA2 55 1C1	5	MA2 55 123	10	MA2 55 1D3	5
LSES 71 L	0.75	4747016	10	4747017	5	4776313	5	4746969	10	4749310	5
LSES 80 L	0.75	IE2 75 010	10	IE2 75 011	5	IE2 75 013	2	IE2 75 012	2	IE2 75 014	2
LSES 80 L	1.1	IE2 11 000	10	IE2 11 001	5	IE2 11 003	2	IE2 11 002	2	IE2 11 004	2
LSES 80 LG	1.5	4764000	10	4764009	2	4764006	2	4764012	2	4764003	2
LSES 90 S	1.5	IE2 15 010	10	IE2 15 011	5	IE2 15 013	2	IE2 15 012	5	IE2 15 014	2
LSES 90 L	1.8	4764054	5	4764072	1	4764066	2	4764078	2	4764060	2
LSES 90 L	2.2	IE2 22 000	10	IE2 22 001	10	IE2 22 003	2	IE2 22 002	5	IE2 22 004	2
LSES 100 L	3	IE2 30 000	10	IE2 30 001	5	IE2 30 003	2	IE2 30 002	5	IE2 30 004	2
LSES 100 LR	3.7	4764162	2	4764180	2	4764174	2	4764186	1	4764168	2
LSES 112 MR	4	IE2 40 000	10	IE2 40 001	5	IE2 40 003	2	IE2 40 002	2	IE2 40 004	2
LSES 112 MG	5.5	4764270	5	4764288	3	4764282	2	4764294	2	4764276	2
LSES 132 S	5.5	IE2 55 010	10	IE2 55 006	5	IE2 55 008	1	IE2 55 007	2	IE2 55 009	1
LSES 132 SU	7.5	IE2 75 030	5	IE2 75 031	10	IE2 75 033	1	IE2 75 032	2	IE2 75 034	1
LSES 132 M	9	IE2 90 030	5	IE2 90 031	1	IE2 90 033	1	-	-	IE2 90 034	1
LSES 132 M	11	4764378	3	4764396	2	4764390	1	4764402	1	4764384	1
LSES 160 MP	11	IE2 11 010	3	IE2 11 011	1	IE2 11 013	1	IE2 11 012	1	IE2 11 014	1
LSES 160 MR	15	IE2 15 030	2	IE2 15 031	1	IE2 15 033	1	IE2 15 032	1	IE2 15 034	1
LSES 160 L	18.5	IE2 18 030	1	IE2 18 031	1	IE2 18 033	1	-	-	-	-
LSES 180 MT	22	IE2 22 030	1	IE2 22 031	1	IE2 22 033	1	-	-	-	-
LSES 200 LR	30	IE2 30 030	1	IE2 30 031	1	IE2 30 033	1	-	-	-	-
LSES 200 L	37	IE2 37 030	1	IE2 37 031	1	IE2 37 033	1	-	-	-	-
LSES 225 MT	45	IE2 45 000	1	IE2 45 001	1	IE2 45 003	1	-	-	-	-
LSES 250 MZ	55	IE2 55 030	1	IE2 55 031 ²	1	IE2 55 033	1	-	-	-	-
LSES 280 SC	75	IE2 75 070	1	IE2 75 071 ²	1	IE2 75 073	1	-	-	-	-
LSES 280 MC	90	-	-	-	-	-	-	-	-	-	-
LSES 315 SN	110	-	-	-	-	-	-	-	-	-	-
LSES 315 MP	132	-	-	-	-	-	-	-	-	-	-
LSES 315 MR	160	-	-	-	-	-	-	-	-	-	-
LSES 315 MR	200	-	-	-	-	-	-	-	-	-	-

1. Motors IM B5 / IM V1 - IM B35 / IM V5 - IM B14 / IM V18 - IM B34 / IM V58 for frame sizes from 80 to 160 MP/MR 2. Motors IM V1
* Foot mounted or flange mounted motors (or foot and flange mounted) with non standard shaft end (D : 14/6 - E : 30 mm).

2 poles
3000 min⁻¹

IP 55 - 50 Hz - Class F - ΔT 80 K - 400 V Δ - S1 - Class IE2

Type	Rated power at 50 Hz P_N kW	IM 1001 (IM B3)		IM 3001' (IM B5)		IM 2001' (IM B35)		IM 3601' (IM B14)		IM 2101' (IM B34)	
		Code	Qty	Code	Qty	Code	Qty	Code	Qty	Code	Qty
LSES 100 L	3	IE2 30 020	2	IE2 30 021	1	IE2 30 023	1	IE2 30 022	2	IE2 30 024	2
LSES 112 MR	4	IE2 40 020	5	IE2 40 021	5	IE2 40 023	1	IE2 40 022	2	IE2 40 024	2
LS 112 MG	5.5	4764271	5	4764289	2	4764283	1	4764295	2	4764277	2
LSES 132 S	5.5	IE2 55 040	5	IE2 55 026	1	IE2 55 028	1	IE2 55 027	2	IE2 55 029	2
LSES 132 SU	7.5	IE2 75 050	5	IE2 75 051	1	IE2 75 053	1	IE2 75 052	2	IE2 75 054	2
LS 132 M	9	IE2 90 050	5	IE2 90 051	1	IE2 90 053	1	IE2 90 052	2	IE2 90 054	2
LS 132 M	11	4764379	5	4764397	1	4764391	1	4764403	1	4764385	1
LSES 160 MP	11	IE2 11 020	2	IE2 11 021	1	IE2 11 023	1	IE2 11 022	1	IE2 11 024	1
LSES 160 MR	15	IE2 15 050	2	IE2 15 051	2	IE2 15 053	1	IE2 15 052	1	IE2 15 054	1
LSES 160 L	18.5	IE2 18 050	2	IE2 18 051	1	IE2 18 053	2	-	-	-	-
LSES 180 MT	22	IE2 22 050	2	IE2 22 051	1	IE2 22 053	2	-	-	-	-
LSES 200 LR	30	IE2 30 050	1	IE2 30 051	1	IE2 30 053	1	-	-	-	-
LSES 200 L	37	IE2 37 050	1	IE2 37 051	1	IE2 37 053	1	-	-	-	-
LSES 225 MT	45	IE2 45 020	1	IE2 45 021	1	IE2 45 023	1	-	-	-	-
LSES 250 MZ	55	4722177 ³	1	IE2 55 051 ²	1	IE2 55 053	1	-	-	-	-
LSES 280 SC	75	4722195 ³	1	IE2 75 091 ²	1	IE2 75 093	1	-	-	-	-
LSES 280 MC	90	4722213 ³	1	-	-	IE2 90 093	1	-	-	-	-
LSES 315 SN	110	4722231 ³	1	-	-	IE2 11 093	1	-	-	-	-
LSES 315 MP	132	4722249 ³	1	-	-	IE2 13 023	1	-	-	-	-
LSES 315 MR	160	-	-	-	-	-	-	-	-	-	-
LSES 315 MR	200	-	-	-	-	-	-	-	-	-	-

1. Motors IM B5 / IM V1 - IM B35 / IM V5 - IM B14 / IM V18 - IM B34 / IM V58 for frame sizes from 80 to 160 MP/MR
2. Motors IM V1 3. Motor fitted with CTP

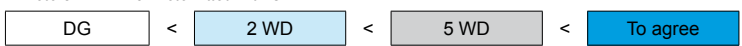

DG: Availability ; n WD: Working Days (at the departure of the factory).



LSES high efficiency three-phase asynchronous motors



Lead times

4
poles
1500 min⁻¹

IP 55 - 50 Hz - Class F - ΔT 80 K - 230 V Δ / 400 V Y - S1 - Class IE2

Type	Rated power at 50 Hz P_N kW	IM 1001 (IM B3)		IM 3001 ¹ (IM B5)		IM 2001 ¹ (IM B35)		IM 3601 ¹ (IM B14)		IM 2101 ¹ (IM B34)	
		Code	Qty	Code	Qty	Code	Qty	Code	Qty	Code	Qty
LS 56 M	0.06	-	-	-	-	-	-	-	-	-	-
LS 56 M	0.09	MA4 09 113	10	MA4 09 115	10	MA4 09 1A5	5	MA4 09 117	10	MA4 09 1B7	5
LS 63 M	0.12	MA4 12 119	10	MA4 12 121	10	MA4 12 1B1	5	MA4 12 123	5	MA4 12 1B3	5
LS 63 M*	0.12	MA4 12 BA1	10	MA4 12 BA2	5	MA4 12 BA4	5	MA4 12 BA3	5	MA4 12 BA5	5
LS 63 M	0.18	MA4 18 107	15	MA4 18 109	10	MA4 18 1A9	5	MA4 18 111	10	MA4 18 1B1	5
LS 63 M*	0.18	MA4 18 BA1	15	MA4 18 BA2	5	MA4 18 BA4	5	MA4 18 BA3	5	MA4 18 BA5	5
LS 71 M	0.25	MA4 25 119	15	MA4 25 121	10	-	-	MA4 25 123	10	-	-
LS 71 M	0.37	MA4 37 119	20	MA4 37 121	10	MA4 37 1A1	5	MA4 37 123	10	MA4 37 1B3	5
LS 71 L	0.55	MA4 55 132	10	MA4 55 133	10	-	-	MA4 55 134	10	-	-
LS 80 L	0.55	MA4 55 113	15	MA4 55 115	5	MA4 55 1A5	2	MA4 55 117	5	MA4 55 1B7	2
LSES 80 LG	0.75	IE4 75 000	15	IE4 75 001	10	IE4 75 003	2	IE4 75 002	5	IE4 75 004	2
LSES 80 LG	0.9	4764702	5	4764711	2	4764708	2	4764714	5	4764705	2
LSES 90 S	1.1	IE4 11 000	15	IE4 11 001	10	IE4 11 003	2	IE4 11 002	5	IE4 11 004	2
LSES 90 L	1.5	IE4 15 000	15	IE4 15 001	15	IE4 15 003	2	IE4 15 002	5	IE4 15 004	2
LSES 90 LU	1.8	4764810	10	4764828	5	4764822	2	4764834	5	4764816	2
LSES 100 L	2.2	IE4 22 000	15	IE4 22 001	15	IE4 22 003	2	IE4 22 002	5	IE4 22 004	2
LSES 100 LR	3	IE4 30 000	15	IE4 30 001	10	IE4 30 003	5	IE4 30 002	5	IE4 30 004	2
LSES 112 MU	4	IE4 40 000	15	IE4 40 001	10	IE4 40 003	5	IE4 40 002	5	IE4 40 004	2
LSES 132 SU	5.5	IE4 55 000	10	IE4 55 001	10	IE4 55 003	5	IE4 55 002	2	IE4 55 004	2
LSES 132 M	7.5	IE4 75 020	10	IE4 75 021	5	IE4 75 023	5	IE4 75 022	1	IE4 75 024	1
LSES 132 MU	9	IE4 90 020	5	IE4 90 021	2	IE4 90 023	2	IE4 90 022	1	IE4 90 024	1
LSES 160 MR	11	IE4 11 020	5	IE4 11 021	1	IE4 11 023	2	4722808	1	4722790	1
LSES 160 L	15	IE4 15 020	2	IE4 15 021	1	IE4 15 023	2	-	-	-	-
LSES 180 MT	18.5	IE4 18 020	2	IE4 18 021	1	IE4 18 023	2	-	-	-	-
LSES 180 LR	22	IE4 22 020	2	IE4 22 021	1	IE4 22 023	2	-	-	-	-
LSES 200 LR	30	IE4 30 020	2	IE4 30 021	1	IE4 30 023	2	-	-	-	-
LSES 225 ST	37	IE4 37 020	2	IE4 37 021	1	IE4 37 023	2	-	-	-	-
LSES 225 MR	45	IE4 45 020	2	IE4 45 021	1	IE4 45 023	2	-	-	-	-
LSES 250 ME	55	4722950 ²	1	-	-	IE4 55 023	1	-	-	-	-
LSES 280 SC	75	IE4 75 040	1	-	-	IE4 75 043	1	-	-	-	-
LSES 280 MD	90	-	-	-	-	-	-	-	-	-	-
LSES 315 SP	110	-	-	-	-	-	-	-	-	-	-
LSES 315 MP	132	-	-	-	-	-	-	-	-	-	-
LSES 315 MR	160	-	-	-	-	-	-	-	-	-	-
LSES 315 MR ¹	200	-	-	-	-	-	-	-	-	-	-

1. Motors IM B5 / IM V1 - IM B35 / IM V15 - IM B14 / IM V18 - IM B34 / IM V58 for frame sizes from 80 to 160 MP/MR 2. Motor fitted with CTP
* Foot mounted or flange mounted motors (or foot and flange mounted) with not standard shaft end (D : 14j6 - E : 30 mm).

4
poles
1500 min⁻¹

IP 55 - 50 Hz - Class F - ΔT 80 K - 400 V Δ - S1 - Class IE2

Type	Rated power at 50 Hz P_N kW	IM 1001 (IM B3)		IM 3001 ¹ (IM B5)		IM 2001 ¹ (IM B35)		IM 3601 ¹ (IM B14)		IM 2101 ¹ (IM B34)	
		Code	Qty	Code	Qty	Code	Qty	Code	Qty	Code	Qty
LSES 100 L	2.2	IE4 22 010	2	IE4 22 011	1	IE4 22 013	1	IE4 22 012	2	IE4 22 014	2
LSES 100 LR	3	IE4 30 010	3	IE4 30 011	1	IE4 30 013	1	IE4 30 012	2	IE4 30 014	2
LSES 112 MU	4	IE4 40 010	5	IE4 40 011	5	IE4 40 013	1	IE4 40 012	2	IE4 40 014	2
LSES 132 SU	5.5	IE4 55 010	5	IE4 55 011	2	IE4 55 013	2	IE4 55 012	2	IE4 55 014	2
LSES 132 M	7.5	IE4 75 030	5	IE4 75 031	2	IE4 75 033	2	IE4 75 032	2	IE4 75 034	2
LSES 132 MU	9	IE4 90 030	2	IE4 90 031	1	IE4 90 033	1	IE4 90 032	1	IE4 90 034	1
LSES 160 MR	11	IE4 11 030	3	IE4 11 031	1	IE4 11 033	1	4722809	1	4722791	1
LSES 160 L	15	IE4 15 030	2	IE4 15 031	2	IE4 15 033	1	-	-	-	-
LSES 180 MT	18.5	IE4 18 030	2	IE4 18 031	1	IE4 18 033	2	-	-	-	-
LSES 180 LR	22	IE4 22 030	2	IE4 22 031	1	IE4 22 033	2	-	-	-	-
LSES 200 LR	30	IE4 30 030	2	IE4 30 031	1	IE4 30 033	2	-	-	-	-
LSES 225 ST	37	IE4 37 030	2	IE4 37 031	1	IE4 37 033	2	-	-	-	-
LSES 225 MR	45	IE4 45 030	2	IE4 45 031	1	IE4 45 033	2	-	-	-	-
LSES 250 ME	55	4722951 ²	1	-	-	IE4 55 033	1	-	-	-	-
LSES 280 SC	75	4722969 ²	1	-	-	IE4 75 053	1	-	-	-	-
LSES 280 MD	90	4722987 ²	1	-	-	IE4 90 053	1	-	-	-	-
LSES 315 SP	110	4723005 ²	1	-	-	IE4 11 053	1	-	-	-	-
LSES 315 MP	132	4723023 ²	1	-	-	IE4 13 053	1	-	-	-	-
LSES 315 MR	160	4723041 ²	1	-	-	IE4 16 053	1	-	-	-	-
LSES 315 MR	200	-	-	-	-	-	-	-	-	-	-

1. Motors IM B5 / IM V1 - IM B35 / IM V15 - IM B14 / IM V18 - IM B34 / IM V58 for frame sizes from 80 to 160 MP/MR 2. Motor fitted with CTP

DG

< 2 WD

< 5 WD

< To agree

DG: Availability ; n WD: Working Days (at the departure of the factory).

LSES high efficiency three-phase asynchronous motors



Lead times

6
poles
1000 min⁻¹

IP 55 - 50 Hz - Class F - ΔT 80 K - 230 V Δ / 400 V Y - S1 - Class IE2

Type	Rated power at 50 Hz P_N kW	IM 1001 (IM B3)		IM 3001' (IM B5)		IM 2001' (IM B35)		IM 3601' (IM B14)		IM 2101' (IM B34)	
		Code	Qty	Code	Qty	Code	Qty	Code	Qty	Code	Qty
LS 63 M	0.09	MA6 09 113	5		-		-	MA6 09 117	5		-
LS 63 M*	0.09	MA0 00 176	5		-		-	MA0 00 182	5		-
LS 71 M	0.12	MA6 12 113	5	MA6 12 115	5		-	MA6 12 117	5		-
LS 71 M	0.18	MA6 18 107	5	MA6 18 109	5		-	MA6 18 111	5		-
LS 71 L	0.25	MA6 25 119	5	MA6 25 121	5		-	MA6 25 123	5		-
LS 80 L	0.25	MA0 00 010	5	MA0 00 011	1	3582084	2	MA0 00 012	2	3778279	1
LS 80 L	0.37	MA6 37 119	5	MA6 37 121	2	MA0 00 050	2	MA6 37 123	2	MA6 37 124	1
LS 80 L	0.55	MA6 55 113	5	MA6 55 115	5	MA0 00 053	2	MA6 55 117	2	MA6 55 114	1
LSES 90 S	0.75	IE6 75 000	2	IE6 75 001 ²	2	IE6 75 003	2	IE6 75 002	2	IE6 75 004	1
LSES 90 L	1.1	IE6 11 000	2	IE6 11 001 ²	2	IE6 11 003	2	IE6 11 002	2	IE6 11 004	1
LSES 100 L	1.5	IE6 15 000	2	IE6 15 001 ²	2	IE6 15 003	2	IE6 15 002	2	IE6 15 004	1
LSES 112 MG	2.2	IE6 22 000	2	IE6 22 001 ²	2	IE6 22 003	2	IE6 22 002	2	IE6 22 004	1
LSES 132 S	3	IE6 30 000	2	IE6 30 001 ²	1	IE6 30 003	2	IE6 30 002	1	IE6 30 004	1
LSES 132 M	4	IE6 40 000	1	IE6 40 001 ²	1	IE6 40 003	1	IE6 40 002	1	IE6 40 004	1
LSES 132 MU	5.5	IE6 55 000	1	IE6 55 001 ²	1	IE6 55 003	1	IE6 55 002	1	IE6 55 004	1
LSES 160 M	7.5	IE6 75 020	1		-	IE6 75 023	1		-		-
LSES 160 LU	11	IE6 11 020	1		-	IE6 11 023	1		-		-
LSES 180 L	15	IE6 15 020	1		-	IE6 15 023	1		-		-

1. Motors IM B5 / IM V1 - IM B35 / IM V15 - IM B14 / IM V18 - IM B34 / IM V58 for frame sizes from 80 to 160 MP/MR
* Foot mounted or flange mounted motors (or foot and flange mounted) with not standard shaft end (D : 14j6 - E : 30 mm).

6
poles
1000 min⁻¹

IP 55 - 50 Hz - Class F - ΔT 80 K - 400 V Δ - S1 - Class IE2

Type	Rated power at 50 Hz P_N kW	IM 1001 (IM B3)		IM 2001' (IM B35)		IM 2101' (IM B34)	
		Code	Qty	Code	Qty	Code	Qty
LSES 132 S	3	IE6 30 010	1	IE6 30 013	1	IE6 30 014	1
LSES 132 M	4	IE6 40 010	1	IE6 40 013	1	IE6 40 014	1
LSES 132 M	5.5	IE6 55 010	1	IE6 55 013	1	IE6 55 014	1
LSES 160 M	7.5	IE6 75 030	1	IE6 75 033	1		
LSES 160 L	11	IE6 11 030	1	IE6 11 033	1		
LSES 180 LR	15	IE6 15 030	1	IE6 15 033	1		
LSES 200 LT	18.5	IE6 18 030	1	IE6 18 033	1		
LSES 200 L	22	IE6 22 030	1	IE6 22 033	1		
LSES 225 MR	30	IE6 30 030	1	IE6 30 033	1		
LSES 250 ME	37		-		-		-
LSES 280 SC	45		-		-		-
LSES 280 MC	55		-		-		-
LSES 315 SN	75		-		-		-
LSES 315 MP	90		-		-		-
LSES 315 MR	110		-		-		-
LSES 315 MR	132		-		-		-

1. Motors IM B5 / IM V1 - IM B14 / IM V18 - IM B34 / IM V58 for frame sizes from 80 to 160 MP/MR

DG < 2 WD < 5 WD < To agree

DG: Availability ; n WD: Working Days (at the departure of the factory).

LSES high efficiency three-phase asynchronous motors



Lead times

2 poles
3000 min⁻¹

Option: CTP thermal protections

IP 55 - 50 Hz - Class F - ΔT 80 K - 230 V Δ / 400 V Y - S1 - Class IE2

Type	Rated power at 50 Hz P_N kW	IM 1001 (IM B3)		IM 3001 ¹ (IM B5)		IM 2001 ¹ (IM B35)		IM 3601 ¹ (IM B14)		IM 2101 ¹ (IM B34)	
		Code	Qty	Code	Qty	Code	Qty	Code	Qty	Code	Qty
LSES 80 L	0.75	4721504	2	4721522	2	4721516	2	4721528	2	4721510	2
LSES 80 L	1.1	4721558	2	4721576	2	4721570	2	4721582	2	4721564	2
LSES 90 S	1.5	4721612	2	4721630	2	4721624	2	4721636	2	4721618	2
LSES 90 L	2.2	4721666	2	4721684	2	4721678	2	4721690	2	4721672	2
LSES 100 L	3	4721720	2	4721738	2	4721732	2	4721744	2	4721726	2
LSES 112 MR	4	4721774	2	4721792	2	4721786	2	4721798	2	4721780	2
LSES 132 S	5.5	4721828	1	4721846	1	4721840	1	4721852	1	4721834	1
LSES 132 SU	7.5	4721882	1	4721900	1	4721894	1	4721906	1	4721888	1
LSES 132 M	9	4721936	1	4721954	1	4721948	1	4721960	1	4721942	1
LSES 160 MP	11	4721990	1	4722008	1	4722002	1	4722014	1	4721996	1
LSES 160 MR	15	4722032	1	4722050	1	4722044	1	4722056	1	4722038	1
LSES 160 L	18.5	4722074	1	4722086	1	4722080	1	-	-	-	-
LSES 180 MT	22	4722104	1	4722116	1	4722110	1	-	-	-	-
LSES 200 LR	30	4722122	1	4722134	1	4722128	1	-	-	-	-
LSES 200 L	37	4722140	1	4722152	1	4722146	1	-	-	-	-
LSES 225 MT	45	4722158	1	4722170	1	4722164	1	-	-	-	-
LSES 250 MZ	55	4722176	1	4722188 ²	1	4722182	1	-	-	-	-
LSES 280 SC	75	4722194	1	4722206 ²	1	4722200	1	-	-	-	-
LSES 280 MC	90	-	-	-	-	-	-	-	-	-	-
LSES 315 SN	110	-	-	-	-	-	-	-	-	-	-
LSES 315 MP	132	-	-	-	-	-	-	-	-	-	-
LSES 315 MR	160	-	-	-	-	-	-	-	-	-	-
LSES 315 MR	200	-	-	-	-	-	-	-	-	-	-

1. Motors IM B5 / IM V1 - IM B35 / IM V5 - IM B14 / IM V18 - IM B34 / IM V58 for frame sizes from 80 to 160 MP/MR
2. Motors IM V1

2 poles
3000 min⁻¹

Option: CTP thermal protections

IP 55 - 50 Hz - Class F - ΔT 80 K - 400 V Δ - S1 - Class IE2

Type	Rated power at 50 Hz P_N kW	IM 1001 (IM B3)		IM 3001 ¹ (IM B5)		IM 2001 ¹ (IM B35)		IM 3601 ¹ (IM B14)		IM 2101 ¹ (IM B34)	
		Code	Qty	Code	Qty	Code	Qty	Code	Qty	Code	Qty
LSES 90 S	1.5	-	-	-	-	-	-	-	-	-	-
LSES 90 L	2.2	-	-	-	-	-	-	-	-	-	-
LSES 100 L	3	4721721	2	4721739	2	4721733	2	4721745	2	4721727	2
LSES 112 MR	4	4721775	2	4721793	2	4721787	2	4721799	2	4721781	2
LSES 132 S	5.5	4721829	1	4721847	1	4721841	1	4721853	1	4721835	1
LSES 132 SU	7.5	4721883	1	4721901	1	4721895	1	4721907	1	4721889	1
LSES 132 M	9	4721937	1	4721955	1	4721949	1	4721961	1	4721943	1
LSES 160 MP	11	4721991	1	4722009	1	4722003	1	4722015	1	4721997	1
LSES 160 MR	15	4722033	1	4722051	1	4722045	1	4722057	1	4722039	1
LSES 160 L	18.5	4722075	1	4722087	1	4722081	1	-	-	-	-
LSES 180 MT	22	4722105	2	4722117	1	4722111	1	-	-	-	-
LSES 200 LR	30	4722123	1	4722135	1	4722129	1	-	-	-	-
LSES 200 L	37	4722141	1	4722153	1	4722147	1	-	-	-	-
LSES 225 MT	45	4722159	1	4722171	1	4722165	1	-	-	-	-
LSES 250 MZ	55	4722177	1	4722189 ²	1	4722183	1	-	-	-	-
LSES 280 SC	75	4722195	1	4722207 ²	1	4722201	1	-	-	-	-
LSES 280 MC	90	4722213	1	-	-	4722219	1	-	-	-	-
LSES 315 SN	110	4722231	1	-	-	4722237	1	-	-	-	-
LSES 315 MP	132	4722249	1	-	-	4722255	1	-	-	-	-
LSES 315 MR	160	-	-	-	-	-	-	-	-	-	-
LSES 315 MR	200	-	-	-	-	-	-	-	-	-	-

1. Motors IM B5 / IM V1 - IM B35 / IM V5 - IM B14 / IM V18 - IM B34 / IM V58 for frame sizes from 80 to 160 MP/MR
2. Motors IM V1

DG

<

2 WD

<

5 WD

<

To agree

DG: Availability ; n WD: Working Days (at the departure of the factory).

LSES high efficiency three-phase asynchronous motors



Lead times

Option: CTP thermal protections

IP 55 - 50 Hz - Class F - ΔT 80 K - 230 V Δ / 400 V Y - S1 - Class IE2

4
poles
1500 min⁻¹

Type	Rated power at 50 Hz P_N kW	IM 1001 (IM B3)		IM 3001 ¹ (IM B5)		IM 2001 ¹ (IM B35)		IM 3601 ¹ (IM B14)		IM 2101 ¹ (IM B34)	
		Code	Qty	Code	Qty	Code	Qty	Code	Qty	Code	Qty
LSES 80 LG	0.75	4722302	2	4722320	2	4722314	2	4722326	2	4722308	2
LSES 90 S	1.1	4722356	2	4722374	2	4722368	2	4722380	2	4722362	2
LSES 90 L	1.5	4722410	2	4722428	2	4722422	2	4722434	2	4722416	2
LSES 100 L	2.2	4722464	2	4722482	2	4722476	2	4722488	2	4722470	2
LSES 100 LR	3	4722518	2	4722536	2	4722530	2	4722542	2	4722524	2
LSES 112 MU	4	4722572	2	4722590	2	4722584	2	4722596	2	4722578	2
LSES 132 SU	5.5	4722626	2	4722644	2	4722638	2	4722650	2	4722632	2
LSES 132 M	7.5	4722680	1	4722698	1	4722692	1	4722704	1	4722686	1
LSES 132 MU	9	4722734	1	4722752	1	4722746	1	4722758	1	4722740	1
LSES 160 MR	11	4722788	1	4722806	1	4722800	1	4722812	1	4722794	1
LSES 160 L	15	4722830	1	4722842	1	4722836	1	-	-	-	-
LSES 180 MT	18.5	4722860	1	4722872	1	4722866	1	-	-	-	-
LSES 180 LR	22	4722878	1	4722890	1	4722884	1	-	-	-	-
LSES 200 LR	30	4722896	1	4722908	1	4722902	1	-	-	-	-
LSES 225 ST	37	4722914	1	4722926	1	4722920	1	-	-	-	-
LSES 225 MR	45	4722932	1	4722944	1	4722938	1	-	-	-	-
LSES 250 ME	55	4722950	1	4722962 ²	1	4722956	1	-	-	-	-
LSES 280 SC	75	4722968	1	4722980 ²	1	4722974	1	-	-	-	-
LSES 280 MD	90	4722986	1	4722998 ²	1	4722992	1	-	-	-	-
LSES 315 SP	110	4723004	1	4723016 ²	1	4723010	1	-	-	-	-
LSES 315 MP	132	4723022	1	4723034 ²	1	4723028	1	-	-	-	-
LSES 315 MR	160	-	-	-	-	-	-	-	-	-	-
LSES 315 MR	200	-	-	-	-	-	-	-	-	-	-

1. Motors IM B5 / IM V1 - IM B35 / IM V5 - IM B14 / IM V18 - IM B34 / IM V58 for frame sizes from 80 to 160 MP/MR
2. Motors IM V1

Option: CTP thermal protections

IP 55 - 50 Hz - Class F - ΔT 80 K - 400 V Δ - S1 - Class IE2

4
poles
1500 min⁻¹

Type	Rated power at 50 Hz P_N kW	IM 1001 (IM B3)		IM 3001 ¹ (IM B5)		IM 2001 ¹ (IM B35)		IM 3601 ¹ (IM B14)		IM 2101 ¹ (IM B34)	
		Code	Qty	Code	Qty	Code	Qty	Code	Qty	Code	Qty
LSES 90 S	1.1	-	-	-	-	-	-	-	-	-	-
LSES 90 L	1.5	-	-	-	-	-	-	-	-	-	-
LSES 100 L	2.2	4722465	2	4722483	1	4722477	2	4722489	2	4722471	2
LSES 100 LR	3	4722519	2	4722537	1	4722531	2	4722543	2	4722525	2
LSES 112 MU	4	4722573	2	4722591	2	4722585	2	4722597	2	4722579	2
LSES 132 SU	5.5	4722627	2	4722645	2	4722639	2	4722651	2	4722633	2
LSES 132 M	7.5	4722681	1	4722699	1	4722693	1	4722705	1	4722687	1
LSES 132 MU	9	4722735	1	4722753	1	4722747	1	4722759	1	4722741	1
LSES 160 MR	11	4722789	1	4722807	1	4722801	1	4722813	1	4722795	1
LSES 160 L	15	4722831	1	4722843	1	4722837	1	-	-	-	-
LSES 180 MT	18.5	4722861	1	4722873	1	4722867	1	-	-	-	-
LSES 180 LR	22	4722879	1	4722891	1	4722885	1	-	-	-	-
LSES 200 LR	30	4722897	1	4722909	1	4722903	1	-	-	-	-
LSES 225 ST	37	4722915	1	4722927	1	4722921	1	-	-	-	-
LSES 225 MR	45	4722933	1	4722945	1	4722939	1	-	-	-	-
LSES 250 ME	55	4722951	1	4722963 ²	1	4722957	1	-	-	-	-
LSES 280 SC	75	4722969	1	4722981 ²	1	4722975	1	-	-	-	-
LSES 280 MD	90	4722987	1	4722999 ²	1	4722993	1	-	-	-	-
LSES 315 SP	110	4723005	1	4723017 ²	1	4723011	1	-	-	-	-
LSES 315 MP	132	4723023	1	4723035 ²	1	4723029	1	-	-	-	-
LSES 315 MR	160	4723041	1	-	-	4723047	1	-	-	-	-
LSES 315 MR	200	-	-	-	-	-	-	-	-	-	-

1. Motors IM B5 / IM V1 - IM B35 / IM V5 - IM B14 / IM V18 - IM B34 / IM V58 for frame sizes from 80 to 160 MP/MR
2. Motors IM V1

DG < 2 WD < 5 WD < To agree

DG: Availability ; n WD: Working Days (at the departure of the factory).

LSES high efficiency three-phase asynchronous motors



Lead times

6
poles
1000 min⁻¹

Option: CTP thermal protections

IP 55 - 50 Hz - Class F - ΔT 80 K - 230 V Δ / 400 V Y - S1 - Class IE2

Type	Rated power at 50 Hz P_N kW	IM 1001 (IM B3)		IM 3001' (IM B5)		IM 2001' (IM B35)		IM 3601' (IM B14)		IM 2101' (IM B34)	
		Code	Qty	Code	Qty	Code	Qty	Code	Qty	Code	Qty
LSES 90 S	0.75	4723076	1	4723094	1	4723088	1	4723100	1	4723082	1
LSES 90 L	1.1	4723130	1	4723148	1	4723142	1	4723154	1	4723136	1
LSES 100 L	1.5	4723184	1	4723202	1	4723196	1	-	-	4723190	1
LSES 112 MG	2.2	4723238	1	4723256	1	4723250	1	4723262	1	4723244	1
LSES 132 S	3	4723292	1	4723310	1	4723304	1	4723316	1	4723298	1
LSES 132 M	4	4723346	1	4723364	1	4723358	1	4723370	1	4723352	1
LSES 132 MU	5.5	4723400	1	4723418	1	4723412	1	4723424	1	4723406	1
LSES 160 M	7.5	4723454	1	-	-	4723460	1	-	-	-	-
LSES 160 LU	11	4723484	1	-	-	4723490	1	-	-	-	-
LSES 180 L	15	4723514	1	-	-	4723520	1	-	-	-	-
LSES 200 LR	18.5	-	-	-	-	-	-	-	-	-	-
LSES 200 L	22	-	-	-	-	-	-	-	-	-	-
LSES 225 MR	30	-	-	-	-	-	-	-	-	-	-
LSES 250 ME	37	-	-	-	-	-	-	-	-	-	-
LSES 280 SC	45	-	-	-	-	-	-	-	-	-	-
LSES 280 MC	55	-	-	-	-	-	-	-	-	-	-
LSES 315 SN	75	-	-	-	-	-	-	-	-	-	-
LSES 315 MP	90	-	-	-	-	-	-	-	-	-	-
LSES 315 MP	110	-	-	-	-	-	-	-	-	-	-
LSES 315 MR	132	-	-	-	-	-	-	-	-	-	-

1. Motors IM B5 / IM V1 - IM B35 / IM V5 - IM B14 / IM V18 - IM B34 / IM V58 for frame sizes from 80 to 160 MP/MR

6
poles
1000 min⁻¹

Option: CTP thermal protections

IP 55 - 50 Hz - Class F - ΔT 80 K - 400 V Δ - S1 - Class IE2

Type	Rated power at 50 Hz P_N kW	IM 1001 (IM B3)		IM 2001' (IM B35)		IM 2101' (IM B34)	
		Code	Qty	Code	Qty	Code	Qty
LSES 132 S	3	4723293	1	4723305	1	4723299	1
LSES 132 M	4	4723347	1	4723359	1	4723353	1
LSES 132 MU	5.5	4723401	1	4723413	1	4723407	1
LSES 160 M	7.5	4723455	1	4723461	1	-	-
LSES 160 LU	11	4723485	1	4723491	1	-	-
LSES 180 L	15	4723515	1	4723521	1	-	-
LSES 200 LR	18.5	4723533	1	4723539	1	-	-
LSES 200 L	22	4723551	1	4723557	1	-	-
LSES 225 MR	30	4723569	1	4723575	1	-	-
LSES 250 ME	37	-	-	-	-	-	-
LSES 280 SC	45	-	-	-	-	-	-
LSES 280 MC	55	-	-	-	-	-	-
LSES 315 SN	75	-	-	-	-	-	-
LSES 315 MP	90	-	-	-	-	-	-
LSES 315 MP	110	-	-	-	-	-	-
LSES 315 MR	132	-	-	-	-	-	-

1. Motors IM B5 / IM V1 - IM B35 / IM V5 - IM B34 / IM V58 for frame sizes from 80 to 160 MP/MR

DG

<

2 WD

<

5 WD

<

To agree

DG: Availability ; n WD: Working Days (at the departure of the factory).

LSES high efficiency three-phase asynchronous motors



Lead times

Option: PTO thermal protection -n/c

IP 55 - 50 Hz - Class F - Δ T 80 K - 230 V Δ / 400 V Y - S1 - Class IE2

2
poles
3000 min⁻¹

Type	P_N kW	Code	Qty
LSES 80 L	0.75	IE2 75 005	2
LSES 80 L	1.1	IE2 11 005	5
LSES 80 LG	1.5	4764001	5
LSES 90 S	1.5	IE2 15 015	2
LSES 90 L	2.2	IE2 22 005	5
LSES 100 L	3	IE2 30 005	5
LSES 112 MR	4	IE2 40 005	5
LSES 112 MG	5.5	4764272	2
LSES 132 SU	7.5	IE2 75 015	2

Option: PTO thermal protection -n/c

IP 55 - 50 Hz - Class F - Δ T 80 K - 400 V Δ - S1 - Class IE2

2
poles
3000 min⁻¹

Type	P_N kW	Code	Qty
LSES 112 MG	5.5	4764273	2
LSES 132 SU	7.5	IE2 75 025	2
LSES 160 LR	15	IE2 15 055	1

DG

<

2 WD

<

5 WD

<

To agree

DG: Availability ; n WD: Working Days (at the departure of the factory).

LSES high efficiency three-phase asynchronous motors



Lead times

4
poles
1500 min⁻¹

Option: PTO thermal protection -n/c

IP 55 - 50 Hz - Class F - ΔT 80 K - 230 V Δ / 400 V Y - S1 - Class IE2

Type	Rated power at 50 Hz	IM 1001 (IM B3)	
	P_N kW	Code	Qty
LSES 80 LG	0.75	IE4 75 005	2
LSES 90 S	1.1	IE4 11 005	10
LSES 90 L	1.5	IE4 15 005	10
LSES 90 LU	1.8	4764812	2
LSES 100 L	2.2	IE4 22 005	10
LSES 100 LR	3	IE4 30 005	5
LSES 112 MU	4	IE4 40 005	10
LSES 132 SU	5.5	IE4 55 005	5
LSES 132 M	7.5	IE4 75 025	10
LSES 132 MU	9	IE4 90 025	5
LSES 160 MR	11	IE4 11 025	5
LSES 160 L	15	IE4 15 025	2

4
poles
1500 min⁻¹

Option: PTO thermal protection -n/c

IP 55 - 50 Hz - Class F - ΔT 80 K - 400 V Δ - S1 - Class IE2

Type	Rated power at 50 Hz	IM 1001 (IM B3)	
	P_N kW	Code	Qty
LSES 132 SU	5.5	IE4 55 015	5
LSES 132 M	7.5	IE4 75 015	5
LSES 132 MU	9	IE4 90 035	5
LSES 160 MR	11	IE4 11 035	5
LSES 160 L	15	IE4 15 035	2

DG < 2 WD < 5 WD < To agree

DG: Availability ; n WD: Working Days (at the departure of the factory).

LSES high efficiency three-phase asynchronous motors



Lead times



Options

Type	Operating position (draining holes at lowest point)						Ventilation cover		
	IM V1' IM 3011	IM V3 IM 3031	IM V5 IM 1011	IM V6 IM 1031	IM V18' IM 3611	IM V19 IM 3631	Steel sheet	Drip cover	Anti-filling
	Code	Code	Code	Code	Code	Code	Code	Code	Code
LSES 80	MAV 80 003	MAV 80 015	MAV 80 025	MAV 80 038	MAV 80 051	MAV 80 059	MATE 1014	MATP 1014	MA00 0247
LSES 90	MAV 90 004	MAV 90 016	MAV 90 026	MAV 90 039	MAV 90 052	MAV 90 060	MATE 1015	MATP 1015	MA00 0248
LSES 100	MAV 100 05	MAV 100 17	MAV 100 27	MAV 100 40	MAV 100 53	MAV 100 61	MATE 1016	MATP 1016	MA00 0249
LSES 112	MAV 112 06	MAV 112 18	MAV 112 28	MAV 112 41	MAV 112 54	MAV 112 62	MATE 1017	MATP 1017	MA00 0250
LSES 132	MAV 132 07	MAV 132 19	MAV 132 29	MAV 132 42	MAV 132 55	MAV 132 63	Standard	MATP 1018	MA00 0251
LSES 160 M	MAV 160 08	MAV 160 20	MAV 160 30	MAV 160 43			Standard	MATP 1019	
LSES 160 L	MAV 160 08	MAV 160 20	MAV 160 30	MAV 160 43			Standard	MATP 1019	
LSES 160 MP	MAV 160 08	MAV 160 20	MAV 160 30	MAV 160 43			Standard	MATP 1019	
LSES 160 LR	MAV 160 08	MAV 160 20	MAV 160 30	MAV 160 43			Standard	MATP 1019	
LSES 180	MAV 180 11	MAV 180 12	MAV 180 64	MAV 180 65			Standard	MATP 1024	
LSES 200	MAV 200 09	MAV 200 21	MAV 200 31	MAV 200 44			Standard	MATP 1020	
LSES 225	MAV 225 10	MAV 225 22	MAV 225 32	MAV 225 45			Standard	MATP 1021	
LSES 250			MAV 250 33	MAV 250 46			Standard	MATP 1022	
LSES 280			MAV 280 34	MAV 280 47			Standard	MATP 1023	
LSES 315							Standard		

1. Motors 2, 4 and 6 poles on white background IM B5 / IM V1 or IM B14 / IM V18.

Option: Drip cover for operation in vertical position, shaft facing down

Dimensions in millimetres

Type	LB'	ø
80	LB + 20	145
90	LB + 20	185
100	LB + 20	185
112 M	LB + 20	185
112 MG/MU	LB + 25	210
132 S/SU	LB + 25	210
132 M/MU	LB + 30	240
160 MP/LR	LB + 30	240
160 M/L/LU	LB + 36.5	265
180 MT/LR	LB + 36.5	265
180 L	LB + 36.5	305
200 LR	LB + 36.5	305
200 L	LB + 36.5	350
225 ST/MT/MR	LB + 36.5	350
225	LB + 55	420
250 MZ	LB + 36.5	350
250 ME	LB + 55	420
280	LB + 55	420
315 SN	LB + 55	420
315 SP/MP/MR	LB + 76.5	505

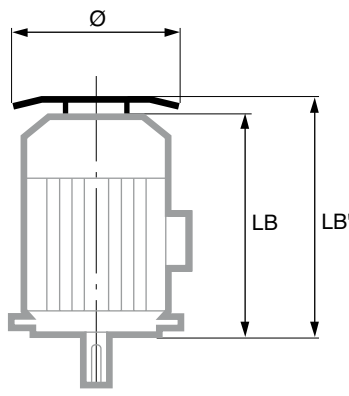

Use guide:

- STEP 1: Select the required basic motor according to the selection grids of the previous pages.
- STEP 2: Select the additional required option or options and add them to the basic designation.

Codification example:

Motor LSES 3-phase 11 kW 3000 min⁻¹ standard flange B5 400 V Δ with PTO and drip cover.



DG < 2 WD < 5 WD < To agree

DG: Availability ; n WD: Working Days (at the departure of the factory).

LSES high efficiency three-phase asynchronous motors



Lead times

Options

2
poles
3000 min⁻¹

4
poles
1500 min⁻¹

6
poles
1000 min⁻¹

Type	Terminal box equipment				Forced ventilation	
	Switch (with aluminium terminal box)	Cable glands		N°	Cable output ¹	Code
		Brass (with aluminium terminal box)	Smaller than standard			
Code	Code	Code	Code	Code	Code	
LSES 80		MAPE 1014	MAPE 1027	13	MASPC 104	MVA 00 068
LSES 90		MAPE 1015	MAPE 1028	13	MASPC 105	MVA 00 001
LSES 100		MAPE 1016	MAPE 1029	13	MASPC 106	MVA 00 063
LSES 112 M		MAPE 1017	MAPE 1030	13	MASPC 107	MVA 00 063
LSES 112 MG		MAPE 1017	MAPE 1030	13	MASPC 107	MVA 00 002
LSES 132 S		MAPE 1018	MAPE 1031	13	MASPC 108	MVA 00 002
LSES 132 M		MAPE 1036	MAPE 1038	16	MASPC 114	MVA 00 064
LSES 160 L		MAPE 1019	MAPE 1032	16	MASPC 109	
LSES 160 M		MAPE 1019	MAPE 1032	16	MASPC 109	
LSES 160 LR		MAPE 1019	MAPE 1032	16	MASPC 109	
LSES 160 MP		MAPE 1019	MAPE 1032	16	MASPC 109	
LSES 180		MAPE 1037	MAPE 1039	16	MASPC 115	
LSES 200		MAPE 1020	MAPE 1033	21	MASPC 110	
LSES 225		MAPE 1021	MAPE 1034	29	MASPC 111	
LSES 250		MAPE 1022	MAPE 1035	36	MASPC 112	
LSES 280		MAPE 1023	MAPE 1036	36	MASPC 113	
LSES 315				36		

¹ Cable length: 1 metre. Conductor number: 6 + 1 (section according to the power and to the mains supply voltage).
Cable connected to the board. Standard terminal box.

Type	PTO	PTF	CTP	Other options			
	Thermal protection opening (n/c)	Thermal protection closing (n/o)	Positive temperature coefficient thermistors probes	Aluminium terminal box	Stainless steel plate	Roller bearings	Aluminium fan
Code	Code	Code	Code	Code	Code	Code	Code
LSES 80	MAPT 1011	MAPT F 101		MABBA 104	MAPLA 104		MA0 002 90
LSES 90	MAPT 1011	MAPT F 101		MABBA 105	MAPLA 105		MA0 003 00
LSES 100	MAPT 1011	MAPT F 101	MACTP 101	MABBA 106	MAPLA 106		MA0 003 01
LSES 112 M	MAPT 1011	MAPT F 101	MACTP 101	MABBA 107	MAPLA 107		MA0 003 02
LSES 112 MG	MAPT 1011	MAPT F 101	MACTP 101	MABBA 107	MAPLA 107		MA0 002 94
LSES 132 S	MAPT 1011	MAPT F 101	MACTP 101	MABBA 108	MAPLA 108		MA0 002 95
LSES 132 M	MAPT 1011	MAPT F 101	MACTP 101	Standard	MAPLA 108		MA0 002 96
LSES 160 L	MAPT 1011	MAPT F 101	MACTP 101	Standard	MAPLA 109	MARR 1011	
LSES 160 M	MAPT 1011	MAPT F 101	MACTP 101	Standard	MAPLA 109	MARR 1011	
LSES 160 MP/MR	MAPT 1011	MAPT F 101	MACTP 101	Standard	MAPLA 109		
LSES 180	MAPT 1011	MAPT F 101	MACTP 101	Standard	MAPLA 114	MARR 1016	
LSES 200	MAPT 1011	MAPT F 101	MACTP 101	Standard	MAPLA 110	MARR 1012	
LSES 225	MAPT 1011	MAPT F 101	MACTP 101	Standard	MAPLA 111	MARR 1013	
LSES 250	MAPT 1011	MAPT F 101	MACTP 101	Standard	MAPLA 112	MARR 1014	
LSES 280	MAPT 1011	MAPT F 101	MACTP 101	Standard	MAPLA 113	MARR 1015	
LSES 315	MAPT 1011	MAPT F 101	MACTP 101	Standard	MAPLA 115	MARR 1017	

DG < 2 WD < 5 WD < To agree

DG: Availability ; n WD: Working Days (at the departure of the factory).