



WALK-BEHIND DUAL-DIRECTIONAL VIBRATORY ROLLERS

- ✓ **HOPPT®** offers FIVE models of Walk-Behind Vibratory Rollers.
- ✓ **Four** of which are Double-Drum Dual-Directional Vibratory Rollers and are fitted with DANFOSS® Hydraulic system for easy manoeuvring and maintenance. One is a Single-Drum Model.
- ✓ All rollers are ergonomically-engineered with such details that ensure optimum comfort and maximum productivity. All rollers are fitted with either single or twin-exciter and twin eccentric masses, which delivers **high centrifugal force**.
- ✓ All models comes in mechanical clutch as standard feature, with electro-magnetic clutch as an option on ROL800.
- ✓ Compaction can also be **done right up** to the **edge of the curbside**, thus Saving Time and Money for additional work.

Series Powered by :



HONDA
ENGINES

Kubota



HOPPT® ROL800

- ✓ **Specially-Designed TWIN-EXCITER System**, creating a very powerful 22.0kn centrifugal force.
- ✓ **Powered by the GERMAN-MADE HATZ® 1B40 Diesel Engines and the Durable JAPAN-MADE KUBOTA® EA330 Diesel Engines** that complies with:
- ✓ EPA Tier-4 Emissions Regulations Standard Exerting Durable Power with a Three Vortex Combustion System (TVCS), which provides Stable Performance even at high engine rpm and an ideal mixture of air and fuel to ensure low-fuel consumption.
- ✓ Thus, ensuring work goes Smoothly and Steadily.



ROL800 with HATZ®



ROL800 with KUBOTA® EA330, Electric-Start

FEATURING HIGH-QUALITY COMPONENTS & FEATURES

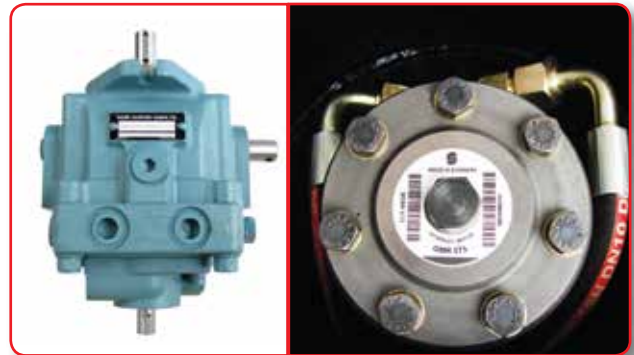

Powered by the HATZ® 1B40 Diesel Engines, GERMANY, and the Durable KUBOTA® EA330 Diesel Engines, JAPAN, that complies with EPA Tier-4 Emissions Regulations Standard

DANFOSS® (Previously Known as Sauer Danfoss) Hydraulic Motors and Pumps for Efficiency, Reliability and Performance

ENGINE SECTION



Fitted with Gas-Spring Hood Covers for Easy Access to the Well-Placed Components during Maintenance (ROL800, 650)

HANDLE SYSTEM

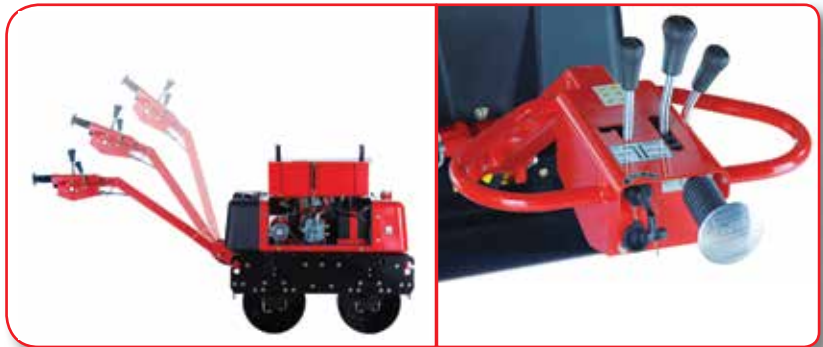

- ✓ Adjustable Handles Designed for Space-Saving during Storage, Well Laid-Out Adjustable Controls on the Handle for Easy Handling
- ✓ Emergency Knobs to Protect the Users



Adjustable High-Power Working Lamps (Nordic, SWEDEN) for Poor Visibility, fitted on all ROL800 and ROL650 with HATZ® engines



Specially-Designed Key and Key-Hole Cover to Prevent Internal Dust Built-Up



Side Hydraulic Oil Gauge for An Easy Check



Large Capacity (47 litre) Water-Tank



Low-Overhang for Compaction Right Up to the Edge of Curbside



Huge Hydraulic Oil Tank (30 litres) for Longer Interval of Oil Change



WALK-BEHIND DUAL-DIRECTIONAL VIBRATORY ROLLERS



ROL550



Woodlands, Singapore - Courtesy of Mr. Thomas JOSEPH



ROL650

Launched in 2015



NORDIC LIGHTS

- HQ located in Sweden
- Designs, manufactures and markets a complete range of high-performance, energy-efficient display lighting fixtures
- 30 years of market presence



DANFOSS

- Specialise in mobile hydraulics and controls business for more than 50 years since 1961
- Provides a wide-range of products and services are used in areas like cooling food, air-conditioning, heating buildings, controlling electric motors and powering mobile machinery

MODEL	ROL800 (Twin-Exciter)	ROL650	ROL550
MACHINE DIMENSION – L x W x H (mm)	2,465 x 754 x 1,170	2,385 x 700 x 1,150	2,295 x 630 x 1,115
OPERATING WEIGHT – (kg)	830	675	565
DRUM SIZE – D X W (mm)	402 x 700	402 x 650	356 x 605
CENTRIFUGAL FORCE – kgf (kN)	2,243 (22.0)	1,100 (10.8)	900 (8.8)
VIBRATION FREQUENCY – Hz (vpm)	55 (3,300)	55 (3,300)	55 (3,300)
MAXIMUM WORKING SPEED – (km/h)	3.6	3.6	3.6
GRADEABILITY – (°)	25	25	25
WATER TANK CAPACITY – (litre)	47	47	35
HYDRAULIC OIL CAPACITY – (litre)	30	30	21
ENGINE OPTIONS	KUBOTA® EA330 @ 5.15kW (6.9hp) 4-Stroke Diesel (Electric-Start)	KUBOTA® E75 @ 4.8kW (6.5hp) 4-Stroke Diesel (Crank & Electric-Start)	KUBOTA® E75 @ 4.8kW (6.5hp) 4-Stroke Diesel (Crank & Electric-Start)
	HATZ® 1B40 @ 7.3kW (9.3hp) 4-Stroke Diesel (Recoil & Electric-Start)	HONDA® GX390 @ 8.7kW (11.7hp) 4-Stroke Petrol (Recoil-Start)	HONDA® GX270 @ 6.6kW (9.0hp) 4 Stroke Petrol (Recoil-Start)
	-	HATZ® 1B40 @ 7.3kW (9.3hp) 4-Stroke Diesel (Recoil & Electric-Start)	-



ROL450

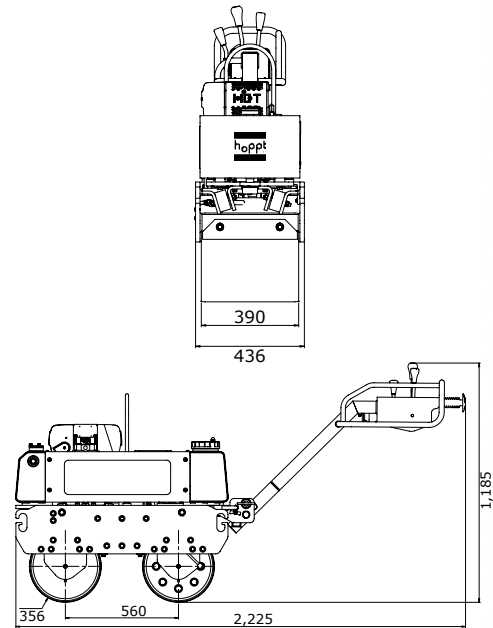

SINGLE-DRUM DUAL-DIRECTIONAL VIBRATORY ROLLER

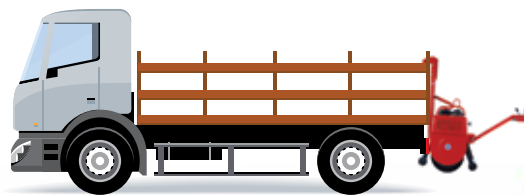

ROL500S



MODEL	ROL500S	ROL450
MACHINE DIMENSION – L x W x H (mm)	2,025 x 930 x 1,962	2,225 x 436 x 1,185
OPERATING WEIGHT – (kg)	500	510
DRUM SIZE – D X W (mm)	575 x 760	356 x 390
CENTRIFUGAL FORCE – kgf (kN)	1,750 (17.2)	2,040 (20)
VIBRATION FREQUENCY – Hz (vpm)	74 (4,380)	43 (2,580)
MAXIMUM WORKING SPEED – (km/h)	3.6	2.7
GRADEABILITY – (°)	25	25
WATER TANK CAPACITY – (litre)	35	15
HYDRAULIC OIL CAPACITY – (litre)	-	12
ENGINE OPTIONS	HONDA® GX270 @ 6.6kW (9.0hp) 4 Stroke Petrol (Recoil-Start)	HATZ® 1B20 @ 3.5kW 4-Stroke Diesel (Recoil-Start)