

## CLCSED TYPE PLATE COMPACTOR

CVP90CG / CVP120CG (GASOLINE ENGINE TYPE)  
CVP90CD / CVP120CD (DIESEL ENGINE TYPE)



### Advantag

- Closed type of plate compactor prevent sand or soil entering into the machines.
- High centrifugal force most suitable for powerful compaction and performance.
- Heavy-duty shock-absorber reduce vibration to engine and handle

### Use

- Compacting soil, gravel, sand and asphalt

### Option

- Engine (Gasoline, Diesel)

### Specifications

MODEL		CVP-90CG	CVP-120CG	CVP90CD	CVP120CD
<b>PLATE COMPACTOR</b>					
OPERATING WEIGHT	kg / lb	88 / 19	120 / 264	103 / 226	133 / 292
DIMENSION (W) x (L) x (H)	mm / inch	415x1,074x872 16.3x42.3x34.3	500x915x985 19.6x36.0x38.7	415x1,074x872 16.3x42.3x34.3	500x915x985 19.6x36.0x38.7
PLATE SIZE	mm / inch	415x545 / 16.3x21.4	500x600 / 19.6x23.6	415x545 / 16.3x21.4	500x600 / 19.6x23.6
CENTRIFUGAL FORCE	KN / kgf	17.7	23.5	17.7	23.5
VIBRATION FREQUENCY	VPM	6,000	6,000	6,000	6,000
TRAVEL SPEED	m(ft) / min	25 / 82	25 / 82	23 / 75	23 / 75
COMPACTED AREA	m <sup>2</sup> (ft <sup>2</sup> ) / hr	625	750	687	825
<b>ENGINE</b>					
BRAND		HONDA	ROBIN	HATZ	KOHLER
MODEL		GX160	EX17	1B20	KD225
TYPE		AIR COOLED 4-CYCLE		AIR COOLED 4-CYCLE	
FUEL		GASOLINE		DIESEL	
OUTPUT	hp / kw	5.5 / 4.125	6.0 / 4.5	4.6 / 3.5	4.8 / 3.6
SPEED	RPM	3,600	3,600	3,600	3,600
TANK CAPACITY	l / gal	3.6 / 0.95	3.6 / 0.95	3.0 / 0.79	3.0 / 0.79
WEIGHT	kg / lb	15 / 33	15 / 33	28 / 61.7	28 / 61.7

### Available engine



## ENGINE TYPE

# BEAM SCREED

CSS-1 & CSS-3

Screed powered by 2 or 4 cycle gasoline engine, provides uniform vibration over the entire screed-bar length and enhances compaction, makes it possible to level up to 4 times more concrete than the traditional method, an it more accurately.

### Features

- Specially design, hardened aluminum screed-bar ensuring a smoother finish than conventional screeds
- Heavy rubber mounts to reduce the vibration level on the handle
- Adjustable handle in height, vertical and horizontal position
- Light weight for operation easily and safely
- The screed bar can make it easy to go around obstacles
- The tilt-up stand keeps the engine out of concrete or off the ground when not in use

### Use

Finishing work for concrete floor & load in job site of any size

### Specifications

MODEL		CCS-1	CCS-3	
WEIGHT	Kg / lb	21 / 46	90 / 198	
DIMENSION (W) x (L) x (H)	mm / inch	770 x 900 x 1,000 / 30.3 x 35.4 x 39.3	375 x 6,000 x 899 / 14.7 x 236.2 x 35.3	
LENGTH OF BEAM	m / inch	1.0 ~ 3.0 / 39.3 ~ 118.1	3.0 ~ 6.0 / 118.1 ~ 236.2	
DRIVE METHOD		FLEXIBLE SHAFT	BELT	
VIBRATION FREQUENCY	VPM	7,000	3,600	
<b>ENGINE</b>				
BRAND		HONDA	HONDA	ROBIN
MODEL		GX35	GX160	EX17
TYPE		AIR-COOLED 4-CYCLE ENGINE	AIR-COOLED 4-CYCLE ENGINE	AIR-COOLED 4-CYCLE ENGINE
FUEL		GASOLINE	GASOLINE	GASOLINE
OUTPUT	Hp / KW	1.6 / 1.2	5.5 / 4.1	6.0 / 4.5
SPEED	RPM	7,000	3,600	3,600
TANK CAPACITY	gal	0.65 / 0.17	3.6 / 0.9	3.6 / 0.9
WEIGHT	Kg / lb	09 / 19	15 / 33	15 / 33

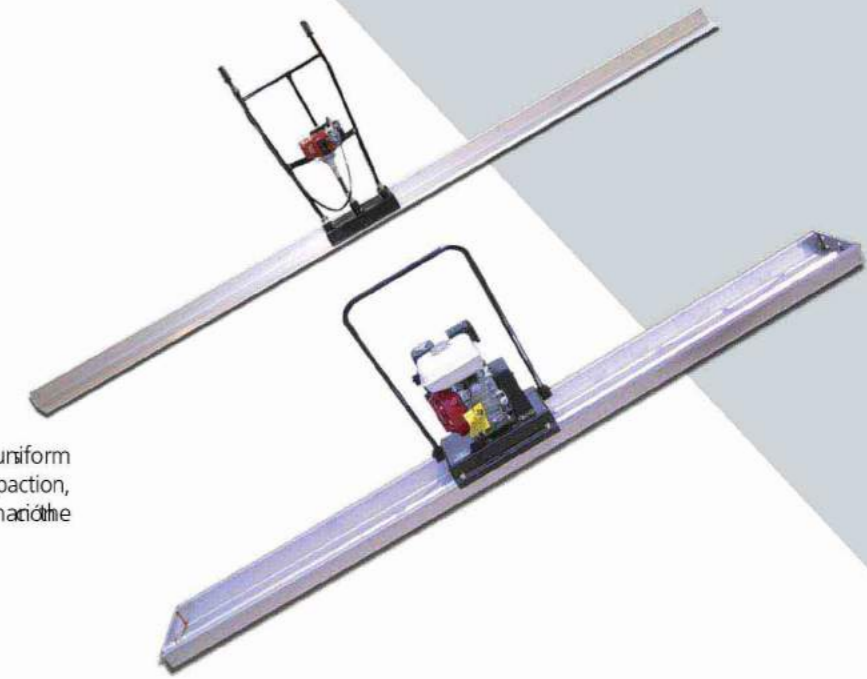

- Screed body easy connects to engine
- Emergency stop switch available
- Easy changeable blades according to different working widths
- Comfort isolation of vibration adapted to the worker
- Adaptability easy adapted to all surfaces
- Performance designed for intense work

### Available Engine

